

J2 TECHNICAL ARTICLE

Number 96

March 30, 1982

From Octagon Heaven

PROPELLER SHAFT TUNNEL SILENCER

For a better term I will call it the "silencer" or "rattle silencer", or maybe even an "oil catcher" or "seal". Regardless of what name we want to hang on the piece, there is a strip of felt on the inside of the front of the propeller shaft tunnel.

This piece of felt is 1½" x 16" long and is held in position by five small round-headed "cotter pins", the same style that are used to hold the rubber silencers on the chassis rails.

In examination of the remains of the piece I took off of my car, I found it to be about the same thickness as the material sold by Moss Motors and Abingdon Spares for black tool box liner material. (¼" thick).

When assembled, this "silencer" forms a snug fit between the tunnel and the rear of the gear box. This then keeps the gear box and tunnel from rattling plus

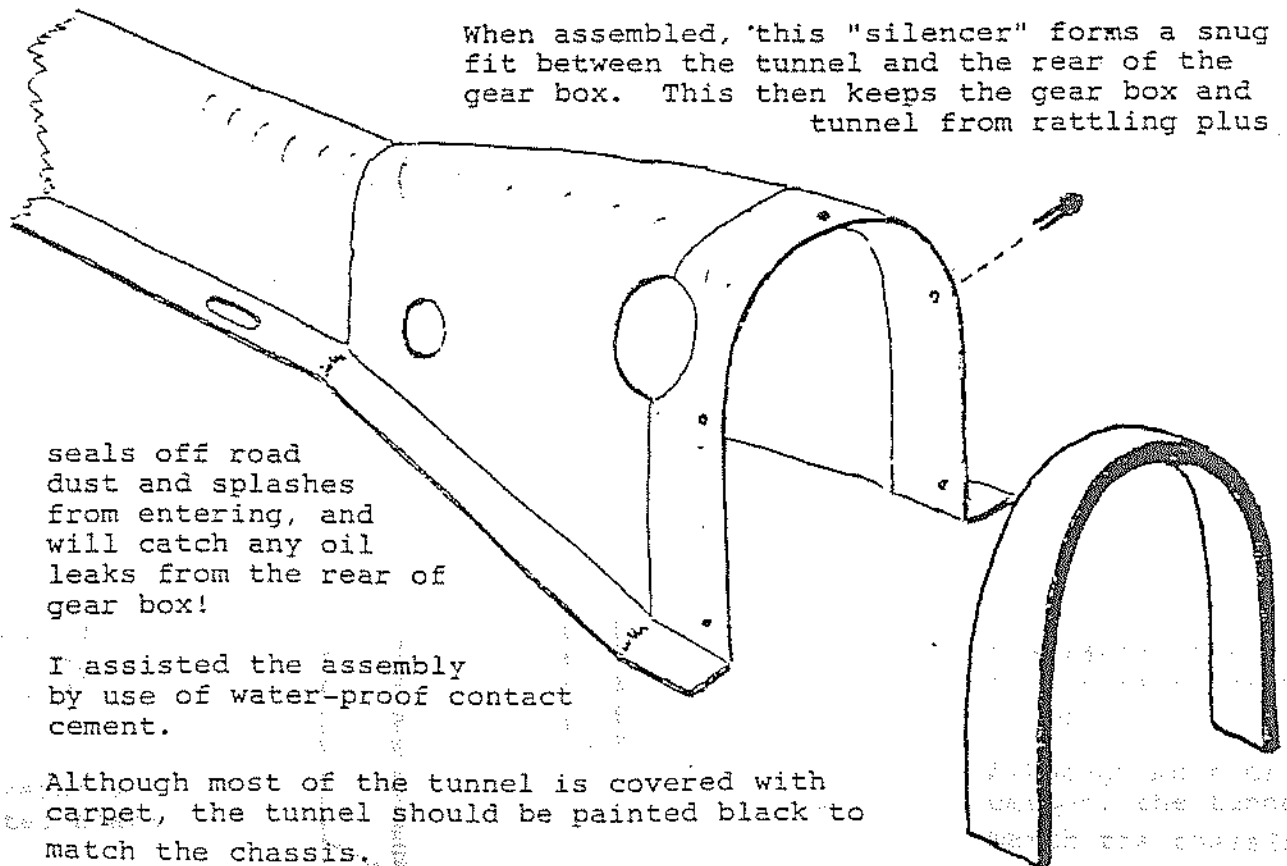

seals off road dust and splashes from entering, and will catch any oil leaks from the rear of gear box!

I assisted the assembly by use of water-proof contact cement.

Although most of the tunnel is covered with carpet, the tunnel should be painted black to match the chassis.