

# **TRIPLE-M REGISTER BULLETIN**



**August 2011**





***Evans Display cars at the Brooklands Society Reunion***



***Christian Hoeptner brought his blown J2 from Germany for the 50th Anniversary, here talking to Peter Tabb***

Photo: Ed Taylor

# **TRIPLE-M REGISTER**

## **BULLETIN No. 62**

**August 2011**

This is my last issue of the Bulletin, but the good news is that we have a new Bulletin Editor, Bob Richards from Cheadle, who is in the throes of rebuilding a P-type. He will be starting with the October issue, so please could you all send him your reports of events, or articles on how you rebuilt your pride and joy. Will everyone please consider how you can help the new Editor in his task, even if it is just a few photos of events or interesting shots of cars in action.

We all heartily thank him for stepping forward to take on this very important task, which most of you seem to find of value, and he is proposing to keep to the bi-monthly issues, even if it means having less pages each time. The proposal to have the Bulletin quarterly is neither one thing nor the other. It is not current enough to keep people up to date with reports of past events and details of forthcoming events, nor is it a 3-monthly version of the Yearbook.

The 50<sup>th</sup> Anniversary celebrations were a great success, and everyone I spoke to seemed to be enjoying themselves. A great debt of gratitude is owed to Elizabeth Taylor for her truly excellent and seamless organisation.

It was nice to have two Australian entries for the 50<sup>th</sup> Anniversary; Ed Taylor had shipped his J3 over especially for the event, and had already done three events before the 50<sup>th</sup> celebrations. George and Marguerite Morgan had left their J2 over here from last year's events, when they had just bought it from Tony Mowbray. They cleaned up on the trophies at the Spa European event, and also at Gaydon, with George's J2 winning his class in the Pride of Ownership, and then went on to win the Concours at Silverstone, for which Marguerite got up at 6.30am to clean and polish the car – that's dedication for you!

At Silverstone, I was pleased to be re-united with my old L-type salonette body, that Rod Ptak of Canada has restored back to original. Rod's chassis was originally a salonette, and the body became spare when a Japanese decide to turn my old car into a racer! It is this sort of dedication that needs to be encouraged.

**Cover photo: The Editor receives his Brooklands 12/12 class winning trophy from Prince Michael of Kent (photo Ed Taylor)**

Also at Silverstone I was unfortunate to meet Rob Kowalski, who was the vandal that removed a perfectly good body off an original K2, so he could turn it into a racer. He said he didn't like the K2 body to which the obvious retort is "well go and buy something that you do like, and not mess up a perfectly good original car". This is the same as changing the lamp shades on a Lalique lamp because you don't like the colour! I'm sorry to say that there are a lot of people who do not appreciate that our cars are not toys, but historic items, that are now all over ¾ Century old, and deserve more respect from owners.

Our final event of the 50<sup>th</sup> Anniversary year is the Continental rally in Normandy from 22<sup>nd</sup>-26<sup>th</sup> of September. This will be the last rally organised by the effective team of John and Lavinia Bevington, so if you are quick they may be able to fit you in. This is always a good weekend with good food, empty roads and good company, and will not be repeated, as the Bevingtons are planning to return to England.

Next year our major event will be held in Scotland, organised by Colin McLachlan and his team, and will be held at the end of May, so start making your arrangements to dovetail this event into holidays or visits to friends/relations.

Our NA Allingham is now running again with its newly sleeved No 6 cylinder following its nasty split from top to bottom; we are hoping that the now wet liner will seal properly and not leak water as has happened with other members liners. It is now having its timberwork repaired, following damage on the Flat Cap and Whippet weekend, where the original rear springs were not up to coping with the rough roads. It is worth while pointing out that the body of this car is all original, as the car has never been restored, and has been gradually repaired and fettled ever since I bought it back in 1967 for £70, driving it home from Tring.

On the minus side our Jarvis F-type was going so well during the 50<sup>th</sup> Anniversary, only to disgrace itself over MG Live by blowing its special head gasket provided by Stefaan Vernys. We are now going to resort to a solid copper gasket, and hope this solves this Achilles heel of these otherwise fine cars.

I would like to thank all those people who have contributed to the Bulletin over the last ten years, and hope they will be joined by more reporters to help our new Editor, Bob Richards, to continue to improve this publication

## **Secretary's report on the Triple-M Committee meeting**

**5<sup>th</sup> June 2011.**

Peter Green, Chairman reported that the 50<sup>th</sup> Anniversary sub-committee had been very busy and that the planning was going according to plan; the level of entries were also encouraging.

George Eagle, Secretary, mentioned that both he and the Chairman had attended the last Council Meeting held at Gaydon in March. The Club has asked Piers Hubbard to form a sub-committee to make recommendations on the appointment of a Club President to replace the late Bill Wallace.

An approach had been made to two people to enquire if they would volunteer to take over the Editorship of the Bulletin – both declined. Committee agreed there is a need to review the cost of badges in the light of the increase in VAT and postage charges.

Bob Martin, Treasurer, reported the VAT returns were all up-to-date as at 31<sup>st</sup> March 2011. He supported the proposal that 1000 copies of Malcolm Green's new book be printed, the selling price to be £25 to entrants of the 50<sup>th</sup> anniversary celebrations and thereafter £30 per copy. It was also noted the Register may need to subsidise the 50<sup>th</sup> Anniversary celebrations.

Robin Hamblett, Registrar, reported he had received 7 notifications over changes in ownership, also 4 new cars were reported – one M-type and 3 N-types found in Ireland. The 2011 version of the Triple-M Register has been sent to the printers, this will be sold at MG Live! as usual.

Mike Linward, Competitions Secretary, confirmed Hamish McNinch, C-type, was leading the Racing Challenge Trophy after 3 events, whilst Frank Ashley (M) and Colin McLachan (PA) were joint leaders in the Speed Championship. As usual Bill Bennett (J2-PA/s) leads both the Slade Trophy and COTY, with David Rushton in 2<sup>nd</sup> and Alex Reid 3<sup>rd</sup> in the COTY. A team of 4 cars raced at VSCC Donnington and acquitted themselves well; the team comprised Hamish McNinch, Barry Foster, Oliver Richardson all in C-types and David Downes' J2.

Peter Hemmings reported sales of the Yearbook have held up well with 425 copies sold. Potential new stock items include Malcolm Green's and Mike Allison's new books, together with the 50<sup>th</sup>

Anniversary brochure. Cat Spoelstra has sent in a few ideas for new stock – as usual any ideas from members are always welcome.

Dick Morbey informed the Committee a much tighter regime now exists for Safety Fast with monthly spreads restricted to 515 words and no pictures or fewer words with pictures; four monthly spreads will have 3000 words plus 6 pictures.

Phil Bayne-Powell confirmed the August issue would his last as Editor and that no volunteer had come forward (*a new Editor has now been found as indicated in the Editorial – Ed*). The Committee decided to canvass the opinions of members by issuing a questionnaire. Peter Green

Yearbook Editor Cathelijne confirmed all articles and pictures had been submitted to the printers and it was hoped to have the new Yearbook ready for sale at MG Live! despite a very tight time scale.

John Reid reported that he felt that all drawings etc should be kept in the central Club archives, and as such the post of Triple-M Archivist wasn't needed. The club have appointed an archivist who is working through all the documents held in Kimber House, where this information should be held. John also indicated his intention to retire from the Committee at the 2012 AGM.

**MIDGET MAGNETTE MAGNA**

M+C+D+J1+J2+J4+F1+F2 F3+PA+PB+Q+R+L1+L2+NA+NB+ND+NE+K1+K2 K3+KN+KD

**30 YEARS OF SERVICE**

**MMM**

**THE SPARES SERVICE YOU CAN RELY ON !**

Phone on **01939 210458** Fax on **01939 210644**

For prompt despatch of stock orders

Open daily: 9.00am - 5.00pm Saturdays: 9.00am - 12 noon

Regular stocks include: New rockers; Oil pump gears; Brake and speedo cables; Hoses; Rubber mouldings; Trunion covers; Trunion bearings; Pistons; Valves and valve springs; Clutch linkages and plates; camshafts and camshaft bearings; Radiator badges; Exhaust systems; Aero screens; Mudguards; Valances and aprons; Large range of paper gaskets; Oil seals and brass shims; Vertical Drive spares, Couplings, etc. New Andre Hartford shock absorbers plus a Reconditioning Service; Wheels rebuilt and stove enamelled; Manifolds Wirecut enamelled. We also offer a high quality Whitmetaling and crankgrinding service and each year undertake a limited number of complete engine, gear box and steering box overhauls.

Now even easier to visit - on the A49 less than 15 minutes from the end of M54 - M6 link.

illustrated catalogue Visa - Mastercard welcome

**MG**

**SPORTS & VINTAGE MOTORS**

SHREWSBURY LIMITED

Upper Battlefield  
Shrewsbury SY4 3DB  
Telephone: 01939 210458  
Fax: 01939 210644

Visa Mastercard

BATHURST ROAD  
BATTLEFIELD

## **Brooklands Double Twelve** **18<sup>th</sup> & 19<sup>th</sup> June**

This is a recently introduced event at Brooklands, and aims to profit from the pre-war Double Twelve events run by the JCC at Brooklands to rival Le Mans. Due to the restriction on racing at night, the original event was split into two days of 12 hours each, with the cars locked away overnight in a park ferme, hence 12/12.

The current format is made up of 12 classes of 12 cars (hence 12/12), and this year there was a class for cars with Brooklands history up to 1931, which the Editorial C-type was entered in, together with Dave Cooksey's ex Goldie Gardner C-type driven by son Nick; with another class for Brooklands cars post 1931, which contained Dave Naylor's L2. There was also a class called the Spirit of Brooklands for pre-war cars without Brooklands history, which included Colin Reynolds in his M-type 12/12 replica (with a small R), Andrew Lovett in another M-type with a full 12/12 inlet and exhaust set-up and fettled by Andy King, and Ed Taylor in his J3. Colin Lee was entered in his J1 but it didn't take part.



**The Editor's C-type dwarfed by two big Bentleys**

Other classes were for Veterans, two of which dated back to 1897, a class for Minis, 3-wheeler Morgans, E-type Jaguars, and pre-war Grand Touring cars amongst others. In other words a very wide selection of cars was to be seen.

Entries were chosen by the organisers from forms submitted by the many hopefuls, and it was only quite late that we were informed that we were chosen – I was pretty sure that the C-type would be in, being a 1931 actual Double Twelve car.

The Saturday was the day of the driving tests, with four in the morning and another attempt at the same tests in the afternoon; the best times from each to count. The tests were pretty simple compared with those produced for the VSCC New Year Driving Tests, even though they were produced by the same team. I was up against some heavy metal in the form of a 4<sup>1</sup>/<sub>2</sub> litre Bentley, a huge great 36/220 SS Mercedes, that Sir Malcolm Campbell used to race, another 3/4<sup>1</sup>/<sub>2</sub>litre Bentley, and others including the Brooklands Museum's own Salmson twin-cam Gran Sport, which was obviously going to be driven gently. So my only real competition was going to be Annabel Jones in the 1926 Interceptor Frazer Nash, who confessed that it was only a recent acquisition, and it had a reverse lock which had to be lifted up before going into, and out of reverse! This seriously affected her times.

During the day we were treated very well with a hospitality marquee providing drinks and snacks throughout the day, and a buffet lunch, all provided free.

The day had promised to be a bit wet, which unfortunately put off roughly a quarter of the entry – the wimps. It actually turned out to be dry most of the day, and not too hot, so that our cars didn't overheat, which they tend to do at driving tests.

Also on the Saturday, the VSCC held their Sprint on the Mercedes World track, which provided a further spectacle for visitors. If that wasn't enough there were also a selection of trade stands to relieve you of your hard earned cash.

On the Sunday most of us returned to do the final two driving tests in the morning, after which the Concours judging started. The results of the driving tests were converted to percentages, so that the fastest car in the class was set at 100% and the rest were given a percentage related to the winning car's time; to this was added the percentage result from the concours, to produce the overall results in each class.

To keep the public and competitors amused for the rest of the day, Brooklands had arranged for parades round the Mercedes World track, and a Test Hill challenge for any cars, which included two Sinclair C5s, which we all thought wouldn't be able to make the top – but did – much to everyone's surprise. This was followed by an ascent by a Segway – that two-wheeled personal transport device. This also astounded people when it eventually reached the top! Finally the Museum's own little buggy was dragged up the hill by sheer manpower of some 25 Scouts, who struggled for nearly four minutes, but did make the top, after much shouted encouragement from the spectators.

Also during the afternoon, the only Napier Lion-engined cars (the Napier Railton and the Napier Bentley) were run up in conjunction with a truck mounted engine, complete with propeller. These created a great noise, and spectacle with flames belching out from the exhausts at times. This was only topped by a Packard Bentley with a 42-litre V12 engine, sporting twelve exhaust stubs down each side. Once warmed up this was able to produce flames from all 24 stubs at the same time – a truly memorable sight. The fourth aero-engined monster was a Rolls Royce fitted with a Rolls Royce Merlin engine.



**The Napier Railton, with the Napier Bentley and Packard Bentley beyond**

Eventually the time came for the results of the weekend's competition to be announced, and the top three cars in each class were lined up on the Campbell Circuit by the Museum entrance, and then

brought down by classes to be presented to Prince Michael of Kent. Our C-type was one of the first three in our class, and as we were being presented to Prince Michael, I was told that I was the winner, which was an amazing moment. I then drove the car up to Prince Michael who handed me a most elegant pewter trophy, suitably inscribed. In the Spirit of Brooklands class, Colin Reynolds came second.



**The Editor proudly displays his impressive trophy**  
**Photo Ed Taylor**

The 12 winning cars were then lined up for the judges to decide the overall winner, while twelve drivers held their breaths. The winner was finally announced as the 1934 Alvis Speed 20 of Richard Wadman.

It was interesting to see that the total time of the C-type in the driving tests was better than all of the historic PVT class, but would have only netted it a third place in the Spirit of Brooklands class, where Colin Reynolds would have beaten us.

Thus a tired but happy Editor drove the C-type home with a huge great grin, which stayed for days!

## Results of MG entrants

### Class J – Historic Brooklands cars up to 1931

	Driving tests total	Concours	overall
1 <sup>st</sup> Philip B-Powell	C-type 133.91secs (100%)	90%	190%
9 <sup>th</sup> Nick Cooksey	C-type 346.22secs (38.68%)	N/A	38.68%

### Class K – Historic PVT Brooklands cars

6 <sup>th</sup> Dave Naylor	L2	203.44secs (70.54%)	89%	159.54%
-----------------------------	----	---------------------	-----	---------

### Class L – Spirit of Brooklands cars

2 <sup>nd</sup> Colin Reynolds	M-type	129.75secs (88.01%)	74%	162.01%
5 <sup>th</sup> Andrew Lovett	M-type	137.75secs (82.90%)	76%	158.90%
6 <sup>th</sup> Ed Taylor	J3	145.39secs (78.54%)	78%	156.54%

**THE  BUG – YOU’LL HAVE DIFFICULTY SHAKING IT OFF, AND THE FOLLOWING WILL DO LITTLE TO HELP...**

WE HAVE THE NEW SPARES SERVICE FULLY BACK IN HOUSE BASED ON OUR OLD CATALOGUE  
WE ALSO SELL THE TYPE OF CAR WE LOOK AFTER – MMM AND EARLY T TYPES

<p><b>NEW AND REBUILT SPARES</b> All can be browsed in our self-service shop or same-day mail order.</p> <ul style="list-style-type: none"> <li>• RUBBERS</li> <li>• ENGINE COMPONENTS</li> <li>• BRAKES</li> <li>• SHOCK ABSORBERS</li> <li>• PINS</li> <li>• PUMPS</li> <li>• ELECTRICAL BOXES</li> <li>• DISTRIBUTORS</li> <li>• GASKETS</li> <li>• WHEELS</li> <li>• HOSES/CLIPS</li> <li>• OIL/PINIONS</li> <li>• RAD GRILLES</li> <li>– LAMPS OF ALL DESCRIPTIONS –</li> </ul>	<p><b>OLD SPARES</b> (usually in stock but subject to availability) The last on-tap s/hand MMM spares service in the UK.</p> <ul style="list-style-type: none"> <li>• ENGINES</li> <li>• CHASSIS PARTS</li> <li>• GEARBOXES</li> <li>• MANIFOLDS</li> <li>• RADIATORS</li> <li>• SHELLS/GRILLES</li> <li>• WHEELS</li> <li>• BRAKES</li> <li>• DRIVESHAFTS</li> <li>• AXLES</li> <li>• HUBS</li> <li>– LAMPS OF ALL DESCRIPTIONS – (restored and unrestored)</li> </ul>	<p><b>MOST RECENT ADDITIONS</b></p> <ul style="list-style-type: none"> <li>• 0-6g. 2400cc 1930s Type 400, 400, 500 + 69 other stock</li> <li>• The new rear 1930s standard wheel</li> <li>• 1/1/1, manufactured rear wire wheels</li> <li>• Original stamped-steel bench &amp; brake tank bottom, 1/6 cast-iron</li> <li>• Double-bubble MMM lounge seats</li> <li>• Wheel hubcap plates for all MG models (1930s)</li> <li>• This new original design gold hub cap</li> <li>• Chromed 1930s head water pump cover</li> <li>• Three new alloy pin supports, 1930s 2.0L</li> <li>• 1930s 1.6/2.0L 1/1/1 wheels for SE MARY</li> </ul>
--	---	--

**LOWER PRICES – NO OBLIGATION – RETURN QUOTES – 70PP. CATALOGUE, FOC**

OR YOU CAN ACCESS IT ALL VIA [WWW.BARRYWALKER.COM](http://WWW.BARRYWALKER.COM)

Why not plan a visit? We're just 10 miles off the M40 at junction 15 – our shop is open plan with no counters, so you can browse around. And you can visit our showroom as well, packed with Triple-10 and T-type cars for sale.

35 YEARS DEVOTED TO ONE MARQUE – THERE'S LITTLE WE CAN'T HELP YOU WITH

COMMISSION CAR SALES: Our highly regarded service is cheap and always available to you. Mt Mtrou 15'

**TEL: 01789 400181/FAX: 01789 400230**  
**EMAIL: [barry@barrywalker.com](mailto:barry@barrywalker.com)**





**BARRY WALKER**  
... for the very best in vintage MGs ...



Barry Lees Farm, Haverhill Hill,  
Temple Grafton, nr Stratford upon Avon,  
Warwickshire, CV34 6NA, UK.

PHONE BEFORE VISITING

# **The MMM Registers' 50<sup>th</sup> Birthday Bash**

## **An Aussie Perspective!**

By Ed Taylor

Q. Did you bring your car all this way for just this event?

Q. And did you drive it all the way??!

A. Well yes and No!

Yes, the chance to celebrate the Registers 50<sup>th</sup> anniversary was certainly an incentive, and as I had always wanted to drive my own car in and around the UK, what better time than this. As many of the readers will know, this year J3762 saw quite a bit of the UK and Europe, and was even used in anger whilst competing in a few mild competitions, before finally being returned to the docks, and eventually its real home (it is somewhere on the water as I write this). It has spent 76 of its 78 years in Australia.

I must say right up front, that the Triple-M Register has provided me with real inspiration and assistance for well over 40 years now, and has been paramount to my enjoyment of owning a vertical drive MG. To spend a few days with as many of those people who have helped me in the past, was an opportunity not to be missed.

The anniversary committee had put together a comprehensive and full 3-day programme that entrants could participate in at their leisure. This programme immediately preceded MG Live at Silverstone, so many of us had a glut of MMM motoring over 6 or so days, depending on how long it took to get there. The organisation was extremely good, and I take my hat off to those involved, especially to Elizabeth Taylor, as the "customer front" for the team. It must be a pre war MG thing, as our very successful bi-annual Beechworth gathering in Australia is run by another very capable female.

I would like to say that the J3 ran faultlessly throughout the week, but after a very wet trip up to the Midlands on the Monday, accompanied by Philip Bayne-Powell in the C-type, and Peter Tabb in the Jarvis F, it actually refused to start on the Tuesday morning. "Bugger", it has never, ever, not started! I sent Philip and Peter ahead to the event start, and after an hour of quiet trouble shooting at our friendly B&B, all was rectified – the points had pitted badly and needed a decent clean and re-set. But they were only new a couple of years

ago! Oh well, too much use and not enough maintenance – all my own fault.

I made good time to Gaydon, and was definitely not the last to arrive. Even so, when I arrived there was already a crowd of many nations present, with Germans, Belgians, Netherlands, and Australians joining the locals. I understand there were at least 80 cars entered, and there were possibly a few more in addition for the following day at Shelsley.

This, the first day, was left to tyre kicking and chatting amongst the Triple-Ms outside, or look and don't touch the cars representing British motoring history inside. As the day wore on, it became brighter and the driving tests commenced. There were six devious tests to challenge the mind, car and navigator. Great fun thanks Mike, especially the last one. If one did not heed Mr Linwood's quiet word of caution as one left the line – something regarding a steep finish didn't he say? – well, then an overshoot or a stall could befall you. The Aussie sporting rivalry commenced then and there. I seconded George Morgan's navigator (wife Marguerite) from under his nose, and proceeded to a class win, much to the disgust of George and my UK host, Philip BP. George got me back, as he easily took a class win in the Pride of Ownership. Thankfully Philip earned a second in both the driving tests and the POO.



**Impressive line-up of cars at Gaydon  
(photo Ed Taylor)**

Wednesday (day 2) dawned bright, and saw us all heading west from our base in Warwick to the historic hillclimb at Shelsley Walsh. We had the hill and all of the facilities to ourselves for the day, which included as many untimed runs up the hill as you could fit in. Passengers were allowed, but helmets (which could be borrowed) were required. It was a magnificent spectacle and very fitting for such an historic location. It was such a thrill driving in the same space as many famous motoring personalities and cars. For most Triple-M, it was foot flat to the board all the way. Those with a blower may have had to ease off a little at the approach to the esses, especially those who had never driven the hill in anger before.

Day 3 was ours to pick and choose. Our organisers had provided a full suite of local attractions to visit, scattered at all points of the compass around Warwick. I headed out behind the J2 of George and Marguerite, and our trip saw us admiring an Elizabethan garden at Kenilworth Castle, and then lunching at the GWR's Toddington station, whilst waiting patiently for the steam service to arrive. It must have run out of puff because only the diesel appeared.



**The Aussies at Kenilworth Castle;  
George Morgan (J2) and Ed Taylor (J3)**

A climb of Broadway tower gave the most amazing views, before we went underground into a Cold War Nuclear bunker, where volunteer members of the Royal Observers Corps would wait and watch patiently, so they could be the first to see the mushroom cloud. To round the day off, all entrants converged on the Stratford Armouries Museum to feed on cream tea, whilst marvelling at how many ways man has invented to kill (or protect) each other.

Most of us were housed in the Hilton hotel complex in the outskirts of Warwick. The dedicated parking was a sight to behold every evening, not only another chance to admire the cars, but also to watch as the inevitable fettling took place, accompanied by a hoard of onlookers giving all sorts of advice. Drinks, motoring movies and an abundance of good company was available on the first 2 nights, and the third was set aside for the anniversary dinner.

The Gala Dinner was a slap up do, with excellent food, a magician, awards and speeches. Chairman Peter Green ably hosted the evening and introduced two guest speakers. Steve Dear (holder of register number 2) was as entertaining as ever, with an amazing selection of jokes.



**An impressive line-up of touring K-types – Teja Fischer, Walter Kallenberg, Martin Jacobs, Peter Hemmings and Ian Mackay’s car driven by John Reid – Photo S. Vernyns**

There was a lump in all our thoughts as Steve reminded us of our great loss in Mike Hawke, but noted that Mike would have thoroughly endorsed all the great fun we had been having. Then followed Barrie (Wizzo) Williams, who entertained us, talking at length about his motoring career, the personalities he worked with and the variety of cars that he had driven, including such exotic stuff as Ferraris, Maseratis, Aston Martins at the Goodwood Revival and other venues; some days he was driving up to 6-8 cars in different races!

The evening closed with presentation of awards, which culminated in a very deserved award of the Wilson McComb Trophy to Dick Morbey, presented by Club Chairman John Day, for his services to Safety Fast. A bouquet of flowers was then presented to Elizabeth Taylor for all her work in organising this successful event.

Well what else can one say? Roll on another 50 years!

The next day we set off for Silverstone and the weekend of MG Live for more Triple-M action.



**A variety of tails at MG Silverstone, with Sam Barrow fixing the tonneau on his F2, driven all the way from Switzerland for the second year running**

Peter Scott	PA	567 CRU	2
Elizabeth Taylor	PA	JB 7524	2
Chris Lewis	PB	MG 4283	1
Keith Leaver	PB	BOK 244	1

### Class C – 6-cylinder cars

Entrant	Car	Registration	Points
Walter Kallenberg	K1	E-KK 1933H	27
John Rogers	L2	AKL 840	17
Terry Hartley	NB	DUB 679	16
Peter Green	K3	JB 7526	15
Teja Fischer	K1	HH-K0 317H	14
Bob Clare	NB	MG 4750	14
Martin Jacobs	K1/KD	ALU 463	13
Peter Hemmings	KN	MG 4282	12
Bob Walker	F1	GY 5141	11
Sam Barrow	F2	ZH 69814	11
Stefaan Vernys	F1	HZR 714	11
Jack van Gelderen	F1	DM-89-11	10
Gaston Lenaerts	L2	LHJ 875	9
Peter Tabb	F1	IU 2474	9
Mike Allison	NA	JB3852	8
David Stansbie	L2	APJ 750	8
John Reid	K1	ADH 360	6
Bill Abbott	NB	JB 6864	6
Gunther Stamm	K3	JB 3182	5
George Eagle	L2	ALA 656	5
Thijs de Groot	F1	VK-16-15	5
Bill Cullen	F1	DX 9913	4

### Gymkhana

#### Class A – small cam 4-cylinder cars

Entrant	Car	Registration	Points
Ed Taylor	J3	CH 0875	283
Philip Bayne-Powell	C-type	RX 8306	299
George Morgan	J2	TJ5050	301

John Haine	M-type	OY 1548	314
Frank Ashley	M-type	PG 1045	317
Colin Henderson	J2	OB 5374	357
Christian Hoeptner	J2	DO-FG86H	437
Martin Gratte	J2	CG 5513	448
Tony Margel	M-type	ST 6963	468
Colin Butchers	M-type	LS 2464	510

### Class B – Large cam 4-cylinder cars

Entrant	Car	Registration	Points
Dick Morbey	PA/B	WV 5012	250
Peter Scott	PA	567 CRU	267
Dave Rowland	PA	OW 5865	288
Barny Creaser	PA	CYE 387	328
Brian Rainbow	PA	MG 3718	331
Ron Warr	PA	BEV 518	342
Chris Lewis	PB	MG 4283	358
Terry Andrews	PA	WO 9320	385
Mike Pancheri	PA	US 8752	496

### Class C – 6-cylinder cars

Entrant	Car	Registration	Points
Bill Abbott	NB	JB 6864	235
Peter Green	K3	JB 7526	235
Graham Finch	NA	DPC 954	268
Jack van Gelderen	F1	DM-89-11	298
Teja Fischer	K1	HH-K0 317H	324
Sam Barrow	F1	ZH 69814	324
Walter Kallenberg	K1	E-KK-1933H	354
Stefaan Vernyns	F1	HZR 714	359
Martin Jacobs	K1/KD	ALU 463	365
Bob Walker	F1	GY 5141	379
Gaston Lenaerts	L2	LHJ 875	419
Gunther Stamm	K3	JB 3182	434
Phillippe Douchet	K3	VD 15251	436

# **MG Live Sprint** **Sunday June 26<sup>th</sup>** **from Mark Dolton**

After a wonderful week of Triple-M anniversary activity we had a final chance to open the throttles around the Silverstone Sprint Circuit. Located in the Shadow of the new “wing” complex, the track was a great challenge for us. It must be said that the Pit complex and viewing gallery on offer to us is better than every other venue on the calendar, great considering that this is a test track. Well done to the MGCC Northern Division for hosting the event, and providing the exceptional weather.

We had a great Triple-M turn out, 12 cars on show. Unfortunately Philip Bayne-Powell withdrew in the C-Type, both car and driver worn out from the miles clocked over the previous week, starting with the Brooklands Double Twelve the weekend before!

Walking the course proved the first challenge, as Phil Coombs and I set off in a traditional clockwise direction, but as the marshals marked out the finish line it was clear a U-turn was required. The track had a nice combination of chicanes, hairpin, sweeping curves joined with some good length straights. We were timed on a lap and 3/4. Powering out of the pit lane completing a full lap, before crossing the finish line just ahead of the pit lane entrance on the second. The classes were split between Blown and Unblown Triple-M cars, so the stage was set.



**Barry Foster roars to victory in the C-Type (Photo A Harrington)**

We had just one practise run, but three timed runs to perfect our lines. With 3 cars on the track at any one time, a few cars were catching each other up, but this car management was very effective, especially with the huge field that had been assembled.

Practise wasn't a true reflection of pace, as everyone cautiously navigated there way round the new course. I had a nervous run with the PB wallowing badly, and feeling like it would tip over on left-hand bends. Very alarming as I reached over and grabbed the passenger door to redistribute my plentiful weight. I don't think anything had changed, just that we had never driven on an anticlockwise course before, which highlighted the issue, but back in the pit lane the wealth of Triple-M wisdom was bestowed upon me! Firstly pump up the tyre pressures, 40PSI back, 36PSI front, and secondly lock up the shock absorbers. Dolton Senior, Foster and McNinch jumped into life as my new pit crew, swarming around the car applying their experienced touches (Button's McLaren crew should have been watching!).

I must admit it was great to have so much help on hand, and actually mostly in agreement. I miss the Triple-M knowledge at some of the events where we have low entries, so having so many around made it a memorable day.



**Pit Crew Excellence on Display, Doltons, Foster and McNinch spring into action! – (Photo A Harrington)**

And boy did it make a difference; the car was a completely different beast to drive and made the rest of the day far more pleasurable, drifting rather than rolling around bends. But the challenging circuit, in the boiling temperatures had us all on our toes.

In the supercharged class, Barry Foster blasted the C-Type to victory, with some seriously quick times, building on his great race the day before. Fred Boothby got quicker and quicker as the day went on, and as he mastered the course was just far too quick for me in the PB. I just sneaked ahead of the Morland PB and McNinch's C-Type to gain 3<sup>rd</sup> place, although I completely messed up my final run with missed gears and a grassy excursion, as I went through the finish line!

Hamish had a busy and frustrating mechanical weekend in the C-Type, and Andrew Morland was struggling with his gearbox (or was that just another excuse Andrew, see you at Loton!☺ ).

Ed Taylor and his Australian J3 couldn't quite match the pace, but had a wonderful run to conclude an amazing few weeks of motor sport in the UK. It was a pleasure to meet Ed at Crystal Palace back in May just after he arrived from Oz, and we hope to see him again very soon.

In the unblown class, Andrew Bradshaw's PA held off Frank Ashley in the strong performing M-Type. David Downes took 3<sup>rd</sup> place in the J2, ahead of the every improving Phil Coombs

It was a wonderful day at Silverstone. Even the unfortunate F1 style guest car that combusted during lunch couldn't dampen the day. A great venue, great hospitality, well run, amazing weather, and more importantly a wonderful collection of cars and members!! Well done to all involved.

### **Triple-M results** **Unblown MMM & Vintage MG's**

1st	Andrew Bradshaw	PA	165.90
2nd	Frank Ashley	M-Type	167.88
3rd	David Downes	J2	168.26
4th	Philip Coombs	J2	176.91
5th	Andrew Harrington	J2	187.38
6th	Sam Barrow	F2	205.30

### **MMM & Vintage MGs Supercharged**

1st	Barry Foster	C Type	138.45
-----	--------------	--------	--------

2nd	Fred Boothby	J2	153.38
3rd	Mark Dolton	PB	157.94
4th	Hamish Mc Ninch	C Type	158.83
5th	Andrew Morland	PB	158.87
6th	Ed Taylor	J3	170.42
	Philip Bayne-Powell	C Type	NS



**12 Triple-Ms line up in the Pit lane for action  
(Photo A Harrington)**

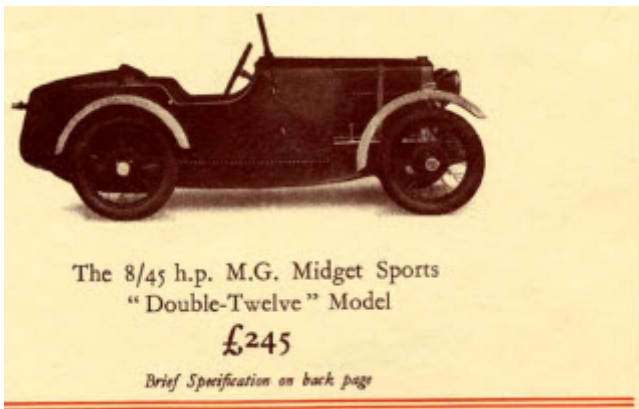

# **VSCC Loton Park Hill Climb**

**By Mark Dolton**

Yet again Loton proved to be my favourite event of the year, another tremendous weekend of action that even the challenging weather could not spoil! The 2-day event is run in the Prescott format of practice on Sat and timed runs on Sun, however Loton has an atmosphere quite different to Prescott. Somehow less manic, relaxed and extremely social. The track, one of the longest we complete provides a real mix of challenges through the glorious deer park setting. Friday eve provides a welcome opportunity to set up camp for the weekend, a relaxing BBQ with friends planning the racing to come, overlooking some amazing views across the Valley.



**Phil Coombs pushes the number roundel-less J2**

**Photo Andrew Harrington**

A fantastic entry had gathered of around 170 cars, with a good Triple-M turnout across the classes. The Rain stayed away until just after breakfast on Saturday morning. In fact just as the paddock filled it came in abundance, very wet! My gazebo was quickly moved from campsite to paddock, to provide a little cover, but the track was most certainly wet for the 1<sup>st</sup> practise. Mini rivers washed down the hill and the 1<sup>st</sup> run proved to be very challenging, and seriously lacking grip. Getting off the line was the first challenge, very little traction at all,

needing a short shift into 2<sup>nd</sup> to stop the wheel spin going. As I sat on the line, I thought I'd broken the clutch or a half shaft, as the revs went high, and the car went nowhere, before slowly inching forward on the ice rink start line.

The sharp right hander at Triangle, after the steep downhill run, and the final right hander at Museum certainly were proving tough to master, and caught a number of the competitors out. I survived a long slide at Triangle, only to fail to hold it at Museum, as the rear wheels came around the car did grip finally, but it snapped back the other way and sent me over the grass, before gingerly finding the tarmac again. Ed Mullins had a similar experience in the K-type, but managed nearly a full pirouette, as he was caught out applying the power. It was a slow morning with multiple red flags as many practised their spin techniques, but as the morning progressed the rain subsided and the track quickly dried.



**Triangle nearly catches me out in the PB or is a beautifully controlled power slide? Photo Andrew Harrington**

If the 1<sup>st</sup> practise had been a survival exercise, 2<sup>nd</sup> practise was amazingly bone dry, warm and a chance to see who had the real pace. Fred Boothby had great 82.49 run, but we would not have a chance to run again in the dry conditions. I had an opportunity for a re- run as the

Nash ahead of me spun on the final corner, as I was nearly at that point when the Flags came out, so I pretty much got an extra free go



**Andy King Powers up the straight in the KN Special – Photo to Peter McFadyen**

As usual Phil Coombs was dropping obstacles along the course in the form of his non-magnetic number roundels. I blame this for my near spin, loss of grip as I ran over it, but I did collect it from the marshal on the way back through!

Amazingly Practice was over by about 4pm, not quite early enough to bag another run, but far too much time to enjoy the delights of a few Speckled Hens. Others obviously had the same idea, as the local ale ran out at 6:30 in the Triangle bar. As ever the hosts laid on a splendid hog roast, and a really enjoyable evening followed. Despite the rain returning and the temperature cooling, the bar area offered an incredibly welcoming atmosphere, and a great opportunity to make new friends across the VSCC.

I was pretty pleased to wake with the tent still in one piece after heavy rain and some pretty strong winds battered us over Sat eve into Sunday morning. We woke early as timed runs were due to start at 8:30am. This was due to a quiet period, Church Service running from 10:30 to Midday. A few mugs of hot tea, a couple of bacon sarnies and we were ready to roll again. The rain eased before the timed runs started, and the first batches benefited from slippery but drying

conditions, but further showers added to the challenge, leaving the classes wide open as the quicker cars struggled for grip.

Andrew “The Master of Excuses” Morland went exceptionally well, although I did have to rescue his unattached spare tyre from the back of the P-type as he prepared to set off at the assembly area. Could have been an interesting exit at the triangle!!



**Andrew Morland mastered the conditions brilliantly to take 2<sup>nd</sup> in class 2 and outpace the other Triple M's in Class 3.**

**Photo Andrew Harrington**

The extended early lunch hour allowed us to dismantle our campsites and have a moment to reflect on our early start, refocusing on the afternoon runs. I was disappointed to find out that at 6ft 5ins, I can't fit into Andy King's Single Seater. For next time.... Andy, If you could move the fuel tank back 6 inches, and use a removable steering wheel, that would be great? ☺

The afternoon remained damp, with persistent light rain, never really allowing the track to dry to let us have a proper crack. But it did mean that the awards were up for grabs. Andrew Morland who continued to improve his times, and made the most of a dry patch to post a 85.25 and take 2<sup>nd</sup> in class 2, certainly had the magic touch in the wet conditions. Phil Coombs is getting quicker and quicker at each event,

taking 2<sup>nd</sup> on handicap and managed to pip David Rushton in the M-Type.

In class 3, the early runners had a drier track, and again I had the opportunity of a rerun as the Nash again was red flagged. Unfortunately this didn't add to my advantage, as I lost a plug sitting stationary whilst they cleared the track. But as the track was getting wetter by the second I don't think I lost too much time, and the plug suddenly picked up, and back to full power heading down hill in to triangle. I finally posted a 87.88 just behind Fred Boothby in the J2 with a 87.04.



**Fred Boothby guides the J2 through the slippery triangle section – Photo Andrew Harrington**

In class 10, Paul Mullins posted an impressive 77.50, and Ed Mullins improved his times on every run, to finish with an 83.50 in the K special. Mike Painter was the quickest Triple-M of the day, with an exceptional 71.32, which deservedly won 2<sup>nd</sup> in class in a very tough line up. Ian Baxter entertained the crowd with too much power in the wet from the Bellevue Special, as he zig-zagged his way spectacularly to the top with a 78.21. Andy King had overcome an intermitted brake issue, which proved a little alarming on the downhill section, to improve his times to 80.77 in class 15.



**Ed Mullins in the K Special tiptoes around triangle**  
**Photo Peter McFadyen**

Another wonderful Loton weekend, really one that we all recommend highly. Thank you to all involved in putting on such a well run event that never missed a beat despite the conditions. It might take a while to dry out, but I will look forward to next year, and I hope we can build on the growing number of Triple-M entrants again in 2012. All the best and fingers crossed for that Prescott Entry in August!

**Results**  
**Class 2 Standard and Modified Sports Cars**  
**751-1100cc Unsupercharged and up to 750cc**  
**Supercharged**

- |                  |           |           |           |
|------------------|-----------|-----------|-----------|
| • Andrew MORLAND | MG PA     | 85.25secs | 2nd       |
| • Philip COOMBS  | MG J2     | 95.1secs  | 1stHc 8th |
| • David RUSHTON  | MG M TYPE | 96.29secs | 9th       |

### **Class 3 Standard and Modified Sports Cars 1100-1500cc Unsupercharged and up to 1100cc Supercharged**

- Fred BOOTHBY                      MG J2                      87.04secs                      5th
- Mark DOLTON                      MG PB                      87.88secs                      6th

### **Class 10 Special Sports Cars 1501-3000cc Unsupercharged and up to 2250cc Supercharged**

- Paul MULLINS                      MG K SPECIAL                      77.50secs                      6th
- Edward MULLINS                      MG K SPECIAL                      83.50secs                      11th

### **Class 13 Pre 1941 Racing Cars up to 1100cc**

- Mike PAINTER                      MG KAYNE                      71.32secs                      2nd

### **Class 14 Pre 1941 Racing Cars 1101-1500cc**

- Ian BAXTER                      MG BELLEVUE SPECIAL                      78.21secs                      8th

### **Class 15 Pre 1941 Racing Cars 1501-3000cc**

- Andy KING                      MG KN Single-Seater Special                      80.77secs                      10th



**BAYNTON JONES**  
**HISTORIC MOTORSPORT**

*RESTORATION, PREPARATION,  
ENGINEERING, SPECIAL PARTS.  
EVERYTHING YOU NEED FOR  
YOUR TRIPLE-M MG.*

FOR MORE DETAILS SEE OUR WEBSITE:  
[www.baynton-jones.co.uk](http://www.baynton-jones.co.uk)

WESTERLEIGH BISHOPSTONE SALISBURY WILTSHIRE SP5 4BW  
Tel. +44 (0) 1747 858915

## **Brooklands Society Reunion** **24<sup>th</sup> June**

I was sorry that we did not get a good turnout of pre-war cars at the Brooklands Society Reunion, where our cars were the featured marque. They missed a historic collection of FIVE Bellevue Garage cars in the special display.

We had the first Evans C-type, the Doreen Evans J2 of Keith Hall (unfortunately without an engine), the newly restored C/R of Mike Dowley, that only fired up for the first time a few days before the event. The 6-cylinder cars were represented by Ian Baxter's Bellevue Special and the trials N-type featured in the 2009 Yearbook.

These were all lined up by the Shell Pagoda, inside which was a display of the Evans family, with 48 trophies of the Evans family inside, together with their photo albums. We also had Wilkie Wilkinson's daughter, Doreen Miller attending. She was named after Doreen Evans, and had brought her father's photo album, covering all the years of his motoring achievements.

Over lunch the cars were displayed in front of the Bellevue Garages "lock-up", before parading along the banking. The sight and sound of Dowley's Zoller-blown car was alone worth being there; the noise was quite fantastic, nearly equalled by the sound from the Bellevue Special.



## **Third Classics at the Centre** **24<sup>th</sup> August**

This charity event takes place at The Memorial Centre, East Common, Gerrards Cross on the afternoon of Wednesday 24<sup>th</sup> August, starting at 3.30pm. This event is open to all pre-1882 cars, for which the entry fee is £5, spectators £1.

The garden Tea Room and Mulberry Bar will be open for refreshments.

Entry forms may be downloaded from [www.gxrotary.co.uk/classiccars](http://www.gxrotary.co.uk/classiccars) or by phoning 07790 928535.

## **MMMs in and around Bremen** **2<sup>nd</sup>-4<sup>th</sup> September**

Our member Klaus Falldorf is organising this Triple-M rally around Bremen. On the Friday evening there is a drive to Bremen Town, and a guided tour of the historic centre, followed by an à la carte dinner.

On Saturday the rally goes to Bremerhaven for a boat tour, snack and tour of the German Emigration Museum, with a 3-course evening meal.

On Sunday the rally goes to Worpswede to see the art gallery, followed by lunch and then departure home.

The entry fee of 120 Euros per person includes entry to Bremerhaven and Worpswede, harbour boat ride, and Saturday evening meal. The rally is limited to only 20 Triple-M cars.

For further details and entry forms contact Klaus on [klaus.falldorf@web.de](mailto:klaus.falldorf@web.de)

## **Goodwood Revival** **16-18<sup>th</sup> September**

This year sees the 80<sup>th</sup> Anniversary of the Earl of March's grandfather's win in the 1931 Brooklands 12/12 in a C-type, and to celebrate this there is going to be a display of C-types over the weekend in front of a mock-up of the Brooklands pits. We understand that there will be at least five C-types in the display.

# **Triple-M Continental Rally**

## **23<sup>rd</sup>-25<sup>th</sup> September**

The last event of the Triple-M's official 50<sup>th</sup> Anniversary events will take place in Normandy, France, under the capable organisation of ex-pats Lavinia and John Bevington.

The event starts with signing in at Hambye on the afternoon of Thursday 22<sup>nd</sup> September, when you will be given your rally pack and final details of the three days of jollities. Any outstanding monies will be collected at this time. There will be a barbeque evening meal to meet up with your fellow entrants.

Friday 23<sup>rd</sup> – after breakfast, we drive to Villedieu, a lovely old historic town, where you can visit the world-famous bell foundry or a museum. You will be asked to choose beforehand from a copper/ pewter/ clock or lace museum. Lunch can be taken in one of the many and varied restaurants or bars in town. The evening dinner will be at a local restaurant.

Saturday 24<sup>th</sup> – after breakfast we drive to the Chateau at Balleroy, where you can go round the chateau, the grounds and the balloon museum. The Chateau is owned by the famous multi-millionaire Malcolm Forbes, who was the first person to cross America in a hot air balloon. After lunch at Le Relais de la Foret, there is a choice of venues for the afternoon; either the gardens at Planbessin or the Abbaye Cerisy-la-Foret. The day is rounded off with an evening meal at a local restaurant.

Sunday 25<sup>th</sup> – after breakfast there will be a scatter rally visiting local villages to answer searching questions. A light bagette lunch will precede the afternoon driving tests. The evening's gala dinner will be held in the Auberge de L'Abbaye.

Monday 26<sup>th</sup> – after breakfast you will be free to make your own way home.

The price of £245/275 Euros per person includes all breakfasts, two lunches, afternoon teas, and three evening dinners, with transport provided, together with entry to all the attractions, including the Rally and driving tests. Accommodation is not provided, as this varies, but will be from 50–60 Euros per room, and will be arranged by our hosts. We ask you to complete the enclosed entry form and send it to me, Philip BP, with a deposit of £50 (56 Euros) per person. You will need to

arrange your own ferry crossings, since these leave from different places, with different prices, also some people may want to stay on longer, and return later. If you want to stay over with John and Lavinia this can be arranged. Most entrants are catching the early morning fast cat from Portsmouth to Cherbourg. We are hoping that our European cousins will make journey to Normandy, as they do not have the cost of the ferry, which us UK entrants will have.

## Inter-Register Club Events - 2011

### ***Date Club Event Location***

Sun 18 <sup>th</sup> Sept	Riley	Scatter	
	North Wilts/ Gloucestershire		
Sun 25 <sup>th</sup> Sept	Crossley	Treasure Hunt	North Yorks
Sat 1 <sup>st</sup> October	Alvis	Scatter Rally	Dartmoor
Sat 19 <sup>th</sup> Nov	ATDC		
NHAEG "Nightjar"	Scatter/Orienteering	Surrey/Hants/ Berks	

For further details and entry forms please contact the Editor, who is the IRC co-ordinator for the Triple-Register.

## FUTURE EVENTS

14 <sup>th</sup> August	Triple-M Black Horse Gymkhana	01372 452133
13-14 <sup>th</sup> August	MGCC Loton Park hill climb	01235 555552
28 <sup>th</sup> August	MG Donington Park race meeting	01235 555552
29 <sup>th</sup> August	SW Centre Ludlow Sprint	01963 440941
3-4 <sup>th</sup> September	MGCC Anglesey Sprint	01625 876300
10 <sup>th</sup> September	Brighton Speed Trials	
10-11 <sup>th</sup> Sept	Beaulieu Autojumble	<a href="http://www.beaulieu.co.uk">www.beaulieu.co.uk</a>
10 <sup>th</sup> September	MGCC Wiscombe Hill Climb	01963 440941
16-18 <sup>th</sup> Sept	Goodwood Revival Meeting	<a href="http://www.goodwood.co.uk">www.goodwood.co.uk</a>
24-25 <sup>th</sup> Sept	Kop Hill Climb	<a href="http://www.kophillclimb.info">www.kophillclimb.info</a>
22-26 <sup>th</sup> Sept	Triple-M Continental Rally	01483 811428

# Car of the Year 2011

## Scores to 28<sup>th</sup> July

Position	Register Number	Car	Registration Mark	Driver/s	Points
1 <sup>st</sup>	909	J2-PA/s	FW 3909	Bill Bennett	99
2 <sup>nd</sup>	3205	K3/s	JB 7526	Peter Green	68
3 <sup>rd</sup>	208	J3/s	CH 0875	Ed Taylor	58
=4 <sup>th</sup>	1140	J2	JL 753	Mike Linward	56
“	1595	M	PG 1045	Frank Ashley	56
6 <sup>th</sup>	1533	PA-PB	WV 5012	Dick Morbey	55
7 <sup>th</sup>	2200	C/s	RX 8306	Philip Bayne-Powell	54
8 <sup>th</sup>	1931	C/s	VD 30	Barry Foster	52
9 <sup>th</sup>	3226	C/s	JO 2288	Hamish McNinch	50
10 <sup>th</sup>	341	M	PJ 7970	David Rushton	46
11 <sup>th</sup>	2170	PB/s	CLX 112	Mark Dolton	43
=12 <sup>th</sup>	2591	PA	MG 3242	Colin McLachlan	42
“	1426	NA/s ss	Bellevue Spl.	Ian Baxter	42
=14 <sup>th</sup>	-	PB	-	Simon Etherington	40
“	250	PA	MG 3294	Andrew Bradshaw	40
16 <sup>th</sup>	2694	J2-PA/s	Kayne Spl.	Mike Painter	39
17 <sup>th</sup>	1804	PA	MG 3848	Alex Reid	37
=18 <sup>th</sup>	3302	J2	KS 6104	Andrew Harrington	36
“	2000	K3/s	MG 3570	Andrew Taylor	36
“	2272	C/s	LJ 4444	Oliver Richardson	36
21 <sup>st</sup>	1018	J2	MG 2853	Philip Coombs	34
22 <sup>nd</sup>	2362	NA	BTT 726	Richard Jenkins	33
=23 <sup>rd</sup>	2236	J2	TJ 5050	George Morgan	32
“	663	F2	ZH 69814	Sam Barrow	32
“	148	M	OY 1548	John Haine	32
=26 <sup>th</sup>	2631	K3/s	JB 1472	Brandon Smith-Hilliard	31
“	907	K1	ADH 360	Neil MacKay/John Reid	31
28 <sup>th</sup>	761	J2	APU 280	David Downes	30
=29 <sup>th</sup>	1581	K1	E-KK 1933	Walter Kallenberg	29
“	108	M	OU 4824	Mike Dalby	29
=31 <sup>st</sup>	211	K1	HH-KO-31 7H	Teja Fischer	27
“	2960	J2	AM-30-25	Thijs de Groot	27
“	3303	M	LS 2464	Oliver Richardson	27
=34 <sup>th</sup>	1777	PA	BEV 518	Ron Warr	26
“	2761	K1/s	MG 2794	Paul Mullins/Edward Mullins	26
“	1550	PA	567 CRU	Peter Scott	26

=37 <sup>th</sup>	2060	PA	OW 5865	David Rowland	25
“	1647	NB	JB 6864	Bill Abbott	25
“	225	K1	ALU 463	Martin Jacobs	25
40 <sup>th</sup>	2284	J2	OB 5374	Colin Henderson	24
=41 <sup>st</sup>	1823	PA	WO 9320	Terry Andrews	23
“	745	F1	DM-89-11	Jack van Gelderen	23
“	2913	PA/s	MG 3855	Andrew Morland	23
“	2133	KN/s ss	-	Andy King	23
“	-	NA/s	BXY 121	Chris Cadman	23
=46 <sup>th</sup>	1551	PA	CYE 387	Barny Creaser	22
“	-	J2/s	WF 5494	Fred Boothby	22
=48 <sup>th</sup>	2175	PB	JB 7524	Elizabeth Taylor	21
“	1270	NB	MG 4750	Bob Clare	21
		Cresta			
=50 <sup>th</sup>	1883	J2	PO 8865	Patrick Gardner	19
“	920	PA	TG 83 37	George Ward	19
“	3	J2	DG 5404	Jeremy Hawke	19
“	423	J2/s	DU-FG 86 H	Christian Höptner	19
“	1168	PB 4str.	MG 4283	Chris Lewis	19
“	1607	F1	HZR 714	Stefaan Vernyns	19
=56 <sup>th</sup>	65	PA/s	DPH 228	Nigel Gibbons	18
“	2823	F1	GY 5141	Robert Walker	18
=58 <sup>th</sup>	73	PA/s	US 8752	Mike Pancheri	17
“	968	PA	BU 8079	Roger Davies	17
“	1027	L2	AKL 840	John Rogers	17
“	605	L1/s	MG 2802	Bob Jones/Charles Jones	17
“	597	PB/s	VV 4538	Peter Haynes	17
=63 <sup>rd</sup>	3303	M	LS 2464	Oliver Richardson/ Colin Butchers	16
“	1146	K3/s	JB 3182	Gunther Stamm	16
“	857	L2	LHJ 875	Gaston Lenaerts	16
“	2193	NB	DUB 679	Terry Hartley	16
=67 <sup>th</sup>	1600	D	PO 5751	Ted Hack	15
“	1521	C/s	RX 8591	Dave Cooksey/Nick Cooksey	15
“	2517	M	SV 6402	Roger Glister	15
=70 <sup>th</sup>	864	PA	LSV 554	Brian Rainbow	14
“	181	C/s	GT 68 28	Robin Gordon	14
=72 <sup>nd</sup>	158	PA	BJO 800	Peter Down	13
“	1985	K3/s	CS 3009	Philippe Douchet	13
74 <sup>th</sup>	1367	PA/s	MG 3921	John Wells	12
=75 <sup>th</sup>	317	Jarvis M	GP 1856	Annette Lee	11
“	1428	J2	DG 6142	Nick Benger	11

“	-	M	-	Paul Russell/David Cutler	11
“	-	PA/s	-	Mike Painter	11
“	670	PA	BFY 711	Richard Holl	11
“	2227	KN	MG 4282	Peter Hemmings	11
“	2188	M	GH 4434	Colin Reynolds	11
=82 <sup>nd</sup>	1794	J1	UF 9856	Colin Lee	10
“	620	NA	DPC 954	Graham Finch	10
“	843	M	ST 6963	Tony Margel	10
“	1659	PA	VL 5643	Terry Davies	10
“	2028	NB/s	MG 3694	Jane Metcalfe	10
=87 <sup>th</sup>	1963	PB	YS 5081	Keith Wallace	9
“	135	KN	BYK 340	Peter Prosser	9
		Saloon			
“	3336	J2	80533	Norbert Welter	9
“	1208	PB	BOK 244	Keith Leaver	9
“	3131	PA	BNA 710	Ray Masters	9
“	1	NA/s	JB 3852	Mike Allison	9
“	1710	F1 Jarvis	IU 2474	Peter Tabb	9
“	-	F1	DX 9913	Bill Cullen	9
“	2979	F1	VK-16-15	Thijs de Groot	9
“	1917	J1/s	VSV 521	Stuart Evans	9
“	397	M 12/12	SC 9559	Alex Peacop	9
=98 <sup>th</sup>	2692	J2	SW 4156	Brian Galbraith	7
“	284	M	MG 533	Andrew Lovett	7
=100 <sup>th</sup>	2715	KN/s	CG 8379	Tanya Lewis	6
“	126	L2	ANB 431	David Naylor	6
“	3298	PA/s	OSL 309	Les Procter	6
=103 <sup>rd</sup>	919	PA/s	DPB 140	Graham Arrondelle	5
“	2579	M	MG 874	Ian Davison	5
=105 <sup>th</sup>	1463	NA/s	BUU 964	David Downes	4
“	407	J2/s	XJ 4982	Peter Batty	4
“	932	J2	CG 5531	Martin Gratte	4
=108 <sup>th</sup>	627	J2	FS 5663	Emma Digby/Kim Jenkins	3
“	2912	C/s	GX 9693	David Potter	3
=110 <sup>th</sup>	994	L2	ALA 656	George Eagle	2
“	1000	PB/s	JB 7521	Brandon Smith-Hilliard	2
“	1135	M	SV 5438	Alan Grassam	2
“	2852	M	RH 5831	Philip Coombs	2
“	3246	J2	AL-37-86	Albert Koolma	2
“	676	PA/s	WP 5939	Roger Thomas	2
“	1418	PA	ARO 872	Paul Ferena	2

“	1976	J2/s	JF 5278	Gil Collins	2
“	3018	PB	MG 4516	Graham Holdsworth	2
“	1997	NA	MG 3271	John Dutton	2
=120 <sup>th</sup>	3272	J2/s	APG 718	Colin Bird	1
“	815	KN/s	MG 4314	Martin Warner	1

Results from the following events are the only ones that have either been submitted or analysed since the last Bulletin, and hence are the only ones that make up the 2011 COTY scores to date. Results can be submitted up to three months after the event took place or later at the Comp. Secs. discretion. However, to be included in the End Of Year final results, a submission must be made no later than the third week of January:

21 <sup>st</sup> /22 <sup>nd</sup> May	VSCC ‘SeeRed’ Donington Park Race Meeting	Full
29 <sup>th</sup> May	Sevenoaks & District MC, Crystal Palace Sprint	Full
4 <sup>th</sup> June	BARC Harewood Hill Climb	Full
11 <sup>th</sup> June	VSCC Cadwell Park Race Meeting	Full
18 <sup>th</sup> June	VSCC Brooklands Speed Trials	Full
18 <sup>th</sup> /19 <sup>th</sup> June	Brooklands ‘Double-Twelve’ Driving Test/Concours	Full
21 <sup>st</sup> /23 <sup>rd</sup> June	Triple-M 50 <sup>th</sup> Anniversary Concours & Driving Tests	Full
25 <sup>th</sup> June	‘MGLive!’ Silverstone International Race Meeting	Full
25 <sup>th</sup> June	Monklands Sporting CC, Forrestburn Hill Climb	Full
26 <sup>th</sup> June	‘MGLive!’ Silverstone Sprint	Full
3 <sup>rd</sup> July	VSCC Shelsley Walsh Clubman’s Hill Climb	Full
16 <sup>th</sup> /17 <sup>th</sup> July	VSCC Loton Park Hill Climb	Full

## SLADE TROPHY 2011

### Scores to 28<sup>th</sup> July

Position	Car/s	Driver/s	Points
1 <sup>st</sup>	J2-PA/s	Bill Bennett	43
=2 <sup>nd</sup>	M	David Rushton	10
“	J2	Thijs de Groot	10
4 <sup>th</sup>	PA	Alex Reid	9
=5 <sup>th</sup>	M	Oliver Richardson	8
“	PA/s	John Wells	8
7 <sup>th</sup>	J2	Patrick Gardner	7
8 <sup>th</sup>	PA	George Ward	6
9 <sup>th</sup>	M	Mike Dalby	5
10 <sup>th</sup>	M	Ian Davison	4

11 <sup>th</sup>	J2	Jeremy Hawke	3
12 <sup>th</sup>	PA/s	Nigel Gibbons	2
=13 <sup>th</sup>	M	Philip Coombs	1
“	PB/s	Brandon Smith-Hilliard	1
“	J2	Brian Galbraith	1

## SPEED CHAMPIONSHIP 2011

### To 30<sup>th</sup> July

Position	Car/s	Driver	Points
1 <sup>st</sup>	PB/s	Mark Dolton	36
2 <sup>nd</sup>	J2	Philip Coombs	31
3 <sup>rd</sup>	NA/s ss	Ian Baxter	26
4 <sup>th</sup>	J2-PA/s	Mike Painter	24
5 <sup>th</sup>	M	David Rushton	23
6 <sup>th</sup>	J2/s	Fred Boothby	21
7 <sup>th</sup>	M	Frank Ashley	20
8 <sup>th</sup>	PA	Andrew Bradshaw	19
9 <sup>th</sup>	PA/s	Andrew Morland	16
=10 <sup>th</sup>	C/s	Barry Foster	14
“	PA	Colin McLachan	14
12 <sup>th</sup>	K1/s	Paul Mullins	13
13 <sup>th</sup>	K1/s	Edward Mullins	11
=14 <sup>th</sup>	J2	Andrew Harrington	10
“	J3/s	Ed Taylor	10
=16 <sup>th</sup>	J2	David Downes	9
“	C/s	Duncan Potter	9
=18 <sup>th</sup>	PA/s	Les Procter	8
“	M	David Cutler	8
=20 <sup>th</sup>	C/s	Hamish McNinch	6
“	C/s	Philip Bayne-Powell	6
“	M	Roger Glister	6
“	NA	Richard Jenkins	6
=24 <sup>th</sup>	KN/s ss	Andy King	5
“	F2	Sam Barrow	5
“	PB/s	Peter Haynes	5
“	M	Paul Russell	5

# Racing Challenge Trophy 2011

## The Betty Haig Cup

### To 29<sup>th</sup> July

	Car/s	Driver/s	No. where less than 5 Races	In dex of Performance
1 <sup>st</sup>	K3/s	Brandon Smith-Hilliard		0.557
2 <sup>nd</sup>	C/s	Hamish McNinch		0.642
3 <sup>rd</sup>	PB	Simon Etherington		0.738
4 <sup>th</sup>	NA/s	Chris Cadman		0.888
	C/s	Barry Foster	2	0.143
	J2-	Mike Painter	2	0.306
	PA/s,PA/ s			
	C/s	Oliver Richardson	2	0.548
	KN/s	Tanya Lewis	2	0.704
	J2/s	Peter Batty	2	0.820
	NB/s	Jane Metcalfe	1	0.286
	PB/s	Peter Haynes	1	0.300
	L1/s	Charles Jones	1	0.400
	K3/s	Peter Green	1	0.571
	K1/s	Edward Mullins	1	0.583
	KN/s ss	Andy King	1	0.600
	M	Alex Peacop	1	0.636
	K3/s	Andrew Taylor	1	0.667
	C/s	Dave Cooksey	1	0.857
	J2	David Downes	1	1.000
	J1/s	Stuart Evans	1	1.000
	K3/s	Philippe Douchet	1	1.000
	J2/s	Andrew Harrington	1	1.000

## Competition Secretary's Report

By Mike Linward

After a successful week, celebrating the Register's 50<sup>th</sup> Anniversary, the tour worked its way through to Silverstone for 'MG Live!', the Main Club's International Weekend, which saw further changes from last year's racing as the Club chose to use the full Grand Prix circuit. While this may be beneficial to some of the competitors, it does not do any

favours for Triple-M cars. At 3.66 miles long it would take a standard unsupercharged car at least four minutes to get round, and most of that in top gear. The Triple-M and T-type race had a grid of 34; 14 Triple-Ms and 20 T-types or T based specials.

In another change to conventional racing, cars were no longer given a number of laps to complete. The race was to last 20 minutes, and finished when the first car crossed the line, after the 20 minutes were up. First of the Triple-Ms was Mike Painter's J2 powered by a supercharged PA engine, and known as the 'Kayne Special' which finished a full minute and six seconds after the race winner. Mike was followed by four cars, and ten seconds later by Charles Jones in his supercharged L-type. A further minute was to pass before the third Triple-M crossed the finish line, Andrew Taylor's K3, followed a few seconds later by the remainder of the Triple-M cars.

A few cars managed to find somebody to race with; Barry Foster (C) and Andy King (KN) kept themselves close together for most of the race, as did Jane Metcalfe in the N-type, and Oliver Richardson in the C-type. Stuart Evans (J1), Peter Green (K3) and Christopher Cadman (NA) were all within ten seconds of each other at the finish, but the remaining four cars driven by Hamish McNinch and Dave Cooksey in C-types, Philippe Douchet in the K3 and David Downes in the J2 looked very lonely as the last of the finishers.

Although most drivers publicly put a brave face on it, saying how much they enjoyed the experience of driving on the longest circuit in Great Britain, from a watches point of view, it had little to commend it. Mike Painter duly took the Kimber Trophy as the leading Triple-M driver and by a quirk of fate, was also awarded the handicap win, and with it the Mary Harris Trophy. As the only unsupercharged four cylinder car David Downes' J2 was awarded the Don Moore Trophy.

In a refreshing change, there were almost as many Triple-M cars entered for the Sunday 'Stowe' Sprint as had raced the day before. The Triple-M entry was split into normally aspirated and supercharged classes. In the former, Andrew Bradshaw's PA was just the winner over Frank Ashley's M-type by less than two seconds. David Downes J2 was third, a further second and a half back. Philip Coombs' J2 was a further 10 seconds back, then another gap of 10 seconds to Andrew Harrington's J2, with Sam Barrow's F2, brought over from Switzerland for the 50<sup>th</sup>, bringing up the rear.

In the supercharged class, Barry Foster's C-type was a clear winner, a good 15 seconds quicker than second place Fred Boothby's C-type. In fact Fred Boothby, Mark Dolton (PB), Andrew Morland (750cc PB) and Hamish McNinch (C) all finished close together in the mid-150 second band. Bringing up the rear in this class was Ed Taylor's J3, a rare and welcome beast indeed, also brought to England, this time from Australia, for the Register's 50<sup>th</sup>.

There was another good entry of 10 Triple-M cars for the Vintage Loton hill climb in July. Best performance was from Andrew Morland, second in Class 2, with Philip Coombs' J2 taking the handicap award. Mike Painter's J2 also took second overall in the small capacity Racing Car class.

The Vintage Speed Trials at Brooklands in June produced limited success for Triple-M cars with Philip Coombs' J2 third in Class 2, and Peter Haynes' supercharged PB, third in the Special Sports-Car class, although the number of entries in both classes was very low.

Over the same weekend, another Brooklands event was taking place; the 'Double-Twelve' combined concours and driving tests. In this, Philip Bayne-Powell's C-type won the Historic Brooklands class for cars that have a Brooklands race history. In the corresponding class for cars without a specific Brooklands connection, Colin Reynolds' M-type took second place.

In the Register championships, trialling has reached the summer recess, and will not restart until September. Bill Bennett can still better the 99 points he has amassed in the COTY, but not by much, as the J2 has already completed more than the ten events required, which gives some hope to the following pack.

The Racing Challenge is nicely placed with four drivers having already completed the minimum number of races to qualify. With diminishing numbers of MGCC organised sprints and hillclimbs available, results from other Club's competitions becomes ever more necessary to find a winner of the Speed Championship. So far this year, Mark Dolton in the supercharged PB has plotted his way through a variety of events with skill and judgement, to lead the Championship by a few points from Philip Coombs' J2. But all this could change with the MGCC SW Centre's Wiscombe Park hill climb in September if the much anticipated, large Triple-M entry, finally materialises.

## **Report from our new Dutch Bulletin Rep** **Jos Schreuders**

The Via Flaminia pre-war 2011 was a huge success. Two MG J2s and a MG TA joined this rally over a distance of 1400 kilometre, from Verona to Rome. The owners were of Dutch, German, Belgium and Danish and British origin.

Also Bentleys a Lagonda, Lancia Theta (1914) and Italas (1907) and a Knox Raceboat (1911), the oldest cars of the rally, joined the group.

On Friday, May 20<sup>th</sup>, most cars boarded the car train in Düsseldorf, in Germany. Arrival in Verona (Italy) was at 10 o' clock in the morning. The start of the Via Flaminia was in the historic town of Mantova.

We were glad to visit the Righini collection. His Castillo houses some 150-200 automobiles

The second day we drove the foot of the Apennines and Monday into Tuscany and Marche. The next day an unpaved mountain pass brought drivers back to civilisation. The MGs still found their way in good condition. We spend the night in Gubbio, the best-preserved medieval town in Italy.



My MG J2 had problems with the petrol tank. Together with the service team, I brought the tank to a place for repair of bicycles. The man (Italian) who could solder the hole in the tank did so with a cigarette in his mouth, and the next day we were at the start again.

In the afternoon we reached Norcia, a lovely, little town and a place for great foot. But that is never a problem in Italy.

Thursday started with great overwhelming views and still almost all the cars kept going. The high plains did fascinate us very much; the cars were in the mood and the MGs passed ' Little Tibet' as if they were made for it.

In no time it was the last day. We drove from the Gran Sasso Mountain towards Rome. Lunch was in the historic centre square of Rieti, and we left town, like before in other historic centres, under police escort. Very exiting, and convenient and the police liked it as much as we did.

Except for an Alvis and, I hate to say it, a MG TA, we all reached Rome safely.

Next year again?



# **THE LONDON TO COPENHAGEN RUN**

## **(or how to move house in an MG J2)**

by Lew & Darlene Palmer

**(First printed in the Octagon Car Club Bulletin in 1987)**

Of course you've heard of the Reliability Run, the GOF Run, the Wings Run from London to Abingdon, and the London to Brighton Run, not to mention other interesting 'Runs' each year. Now we wish to add another run to the growing list, the 'London to Copenhagen Run'. The rules of this Run are really very simple. First: only one M.G. car is allowed in the run; second: the car must be over fifty years old; and third: you must move your entire household at the same time. Now, doesn't that sound like fun?

The first thing is to give yourself plenty of time to prepare for the run; about four weeks should do it. Keep in mind that during this time your employers have cheerfully informed you that they're moving you to another country immediately. You must remember every person and business to notify of a change of address, you must get approval from the country you're going to (to live and work there), buy translation dictionaries to understand the language, call the moving company to move your household goods, decide to drive your personal car there, or have the moving company transport it for you (at your expense, so the decision is obvious), and pack take-with luggage to last for two to three weeks until the moving vans arrive at your new house.

Oh yes, there are several smaller points to note, the 'over-fifty-year-old-MG.' must have less than 200 miles on a ground-up-restoration, two weeks before the start of the run the head-gasket needs replacing, two days before the start the entire braking system needs a complete overhaul, and the navigator has come down with a very nasty cold. (By now I'll bet you can't wait for next year's run).

OK now it's Friday, the day before the run starts. The movers have come and gone. You can get the car out of hock today from the brake repair people and (remember that take-with luggage mentioned earlier), there are two large suitcases and miscellaneous items to fit into a tiny car that was never built for touring purposes in the first place. Well. I ask you, where does one put all that luggage? A fast call to a very good friend and he agrees to follow us to the Harwich ferry in our British company car with our large suitcases. Also our R.A.C. coverage runs our after we've left England, and we have complete coverage in Denmark with FALCK, in case we need recovery service for our car. Well, Saturday's early morning start doesn't look quite so bleak now.

There is a calm, pleasant start to Saturday. By 8.30 we have the smaller suitcase and briefcase on the luggage rack (the rack wasn't an original factory option, so we hope ours works). The mechanic's tools and other miscellaneous items have been tucked behind the seats and in the doors, one last look at our house, a wave goodbye to our neighbour and the 'London to Copenhagen Run' is underway.



## **BAYNTON JONES HISTORIC MOTORSPORT**

***RESTORATION, PREPARATION,  
ENGINEERING, SPECIAL PARTS.  
EVERYTHING YOU NEED FOR  
YOUR TRIPLE-M MG.***

FOR MORE DETAILS SEE OUR WEBSITE:

**[www.baynton-jones.co.uk](http://www.baynton-jones.co.uk)**

WESTERLEIGH BISHOPSTONE SALISBURY WILTSHIRE SP5 4BW

Tel. +44 (0) 1747 858915

Our first scheduled stop is on the M1 Motorway, the Scratchwood Services, where we are to meet our friends with our company car and remaining luggage, by 11.00 a.m. To get there we have to drive through the greater London area from the south of London to the north side of London, and no motorways on this leg of the journey. To complicate matters, we decide against taking the direct route, because it goes through the troubled section of Brixton, where street rioting happened several days earlier.

We've given ourselves two and a half hours to go 25 miles and we hope nothing goes wrong or breaks on this part of the trip, because we are entirely on our own. Soon, however, the smiles and waves our little car creates in others help us to relax a little and we arrive at our scheduled stop at 9.45, one and a quarter hours ahead of schedule (in the face of adversity. arrive early).

Our 'cute little car' mingles with the other cars while we go for coffee inside the services restaurant. A little later, while we try to rearrange our luggage (again), an elderly couple strike up a conversation with us about the car they used to have years ago which was just like ours. Listening to their vivid memories and picturing the fun they surely must have had, brings a tear to my eye. Finally they ask for permission for their grandson to take a picture of the four of us next to Judder (our J2). I honestly can't think of a better impromptu goodbye present to us from England. We can't remember their names and I'm sure they can't remember ours, but we'll never forget their faces and enthusiasm.

The time flies by and soon our friends arrive, right on schedule. Five minutes of re-arranging our luggage (this is becoming habit forming) to our company car and we're off again on the second part of our run. We travel for one-and-a-half- hours and stop for lunch at a roadside pub. Then off again to catch the five o'clock ferry at Harwich. We arrive at the Harwich docks at 2 pm., three hours ahead of schedule (is this getting boring yet?).

We play the waiting game again by checking in with the ferry company - DFDS, trying to figure out how to get all our luggage now into the J2 (remember the extra luggage is in our British Company car), chatting with our dear friends who wait to see us off, and meeting the couple in the car behind us in our lane who happen to be Danish. (If you aren't thoroughly confused by now then you haven't been reading this carefully enough).

By 4.30 the cars start going aboard the ferry. One last goodbye to our friends and a mad dash to get into our car as the car ahead of us starts to move off. With both suitcases on the luggage rack (if you don't believe me, see the picture), and everything else on the navigator's lap, we drive through passport control and onto the ferry (with fingers crossed that nothing falls off our car).



As we are directed to the front of the ferry to park the car I feel as though someone should be waving a chequered flag at this point of the run because we actually made it in one piece. Quickly we cover the car and proceed to the upper decks to find our sleeping room for the cruise. Now for 20 hours of R. & R.

The cruise across the North Sea is beautiful. We couldn't have had better weather if we'd planned it ourselves. After looking around the ship and taking pictures of the setting sun and sea, we have dinner with our new Danish friends. Later we retire to the lounge and continue our conversation over drinks.

Around 11 p.m. the full day of exciting events catches up with us, and it's off to our cabin for a well-deserved night's sleep. Very quickly the gentle rocking of the ship changes our hazy conversation to dreams of the last two years in England. Several short hours later, the dawn proclaims the start of the next chapter of our lives and the London to Copenhagen run.

By 1.30, Sunday afternoon, we are closing in on the Esbjerg docks on the west coast of Denmark. A sudden thought panics us. 'What do we do with all the extra luggage again?' (Never fear, read on).

Our minds go back to an offer made by our newly-found Danish friends to carry the largest suitcase with them to be delivered to Copenhagen the following week. Hurriedly, we locate them and accept the offer. Later we are to find that this leaves us with only the bare minimum of clothes for four days, but never mind.

With most of our worldly belongings on the back of Judder (and the front wheels pointing slightly skyward), we drive off the ferry and through customs control. Our worst fears of not being allowed in until we have paid the import duties on the car never come true. We drive right through customs without a second look. (Danish import duty on cars, you see, is 300 per cent.) A short stop to change a tire which was suffering under the strain, and we are on our way. Now, if we can only remember to drive on the righthand side of the road.

As we drive on into Denmark the last leg of our run begins. Again our little car brings smiles to the people we pass and lots of waving. Since our J2 is only the second J2 in Denmark (so we've been told), we seem to be creating a minor sensation as we go along. The sun is out and the weather is very nice, in spite of being on the cold side. However, we find one small troublesome problem, which needs correcting soon. A right turn into a dirt side road and we begin to discuss possible solutions, Our problem? Would you believe, re-arranging our luggage?

We can't leave the suitcase and briefcase on the luggage rack, because it causes too much weight in the back and the steering up front is too light. So, should we take out the navigator's seat and place the suitcase there instead (it doesn't fit there, too big) or try to tie it on the front by the radiator grille (too big again), or maybe the navigator could carry it on her lap (too heavy and it hangs halfway out of the car) or, but wait! We've been searching for a solution with the hood up. We put the hood down and start again. Finally, after a half hour of creative thinking and an audience of two people and the neighbourhood cow, we arrive at a passable solution. The suitcase sits on the tonneau behind our heads and the small briefcase on the luggage rack. It looks ridiculous, and the visibility to the rear is non-existent, but it works and we're off once again, rushing to catch our next (and last) ferry by 6.00 at Nyborg.

Eventually we cross a very large and beautiful bridge at Fredericia, drive through some small and beautiful villages, continue to see people waving (this really does amaze us) and finally arrive to catch our 6.00 ferry at 4.45 (does that sound familiar?) Because we're early (again), they let us go aboard the 5:00 ferry instead. We're the last car on and the sun is beginning to set behind us.

Once again it's upstairs to the restaurant to eat, and 45 minutes later we rush back to the car as we arrive on the west coast. The sun has set and the temperature has also dropped a bit, so we drive off the ferry and stop just down the road to put

on warmer clothing. We check all the luggage (for the last time, hurrah!) to be sure it's secure and it's off into the night with 75 kilometers left to the end of the run.

At 8.00 Sunday night, 36 hours after the starting gun, we arrive at our hotel in Copenhagen. Judder now has clocked 300 miles (of a total of 500 since restoration) and we are very tired, very cold and very hungry. But the first (and hopefully last) 'London to Copenhagen Run' is finally complete.

## **The perennial Triple-M petrol valve problem**

From John Harris

How many of us have cursed when our cars seem to hesitate when we put our foot down only to find that air is being sucked into the fuel line. "That B.....dy valve again".

The first time this happened to me was when Mike, my son-in-law, and I were on our way back from Cornwall having taken part in the Cornish Riviera Run. The problem started as we were bombing sweetly along the A30 and came to an incline, when the engine started misfiring. This happened every time I put my foot down to demand more fuel. Having swapped petrol pumps to no avail, we concluded that we were sucking air into the line. We temporarily overcame this problem with the piece of rubber hose connecting the fuel line directly to the pump, and with sticky tape blanking off the other fuel line.

Following this event I replaced the cork component in the valve. Just in case this should occur again (and it did, several times), I made up a small kit of parts in copper tube to fit at the side of the road. I have replaced the cork item several times over the years, which haven't lasted long. I had to fit my little "kit" while on the St. George's Day run with the Abingdon Works Centre this year.

Talking to Peter Down, who was following us, having no-one to navigate, he told me that he had fitted a piece of PTFE instead of the cork, as he had been having the same problem. This

prompted me to consider a more permanent solution, either by doing what Peter has done, or something new.

Firstly I took the whole valve apart, and measured all the bits. I discovered that the inner spindle assembly (Figure 1) didn't go right to the bottom of the valve body (Figure 2).

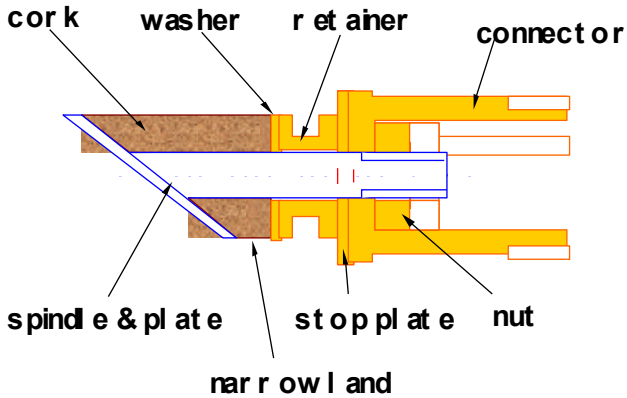

**exist ing spindl e assembl y**

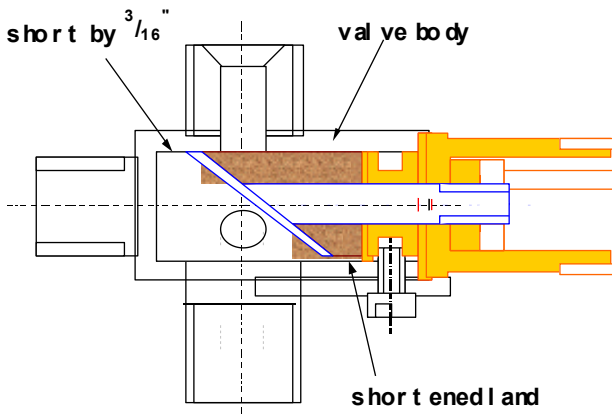

**exist ing val ve assembl y**

This explains why, when I replaced the cork item every time, I had to cut a piece off the wide end of the cork so that the components could be assembled, and I could get the nut on the thread. My guess is that at sometime in the past, the thread has been damaged, and the shaft section of the spindle and plate has been cut back and re-threaded. This makes the land at the outer (wide) end of the cork very narrow and vulnerable to leakage when the cork dries out. Being unable to get new inner bits, I decided it was time to engineer a modification of my own and make new inner bits.

Rather than make another spindle to replace the shortened one, I decided to go for a cylindrical design with an "O" ring to seal the shaft and a PTFE cylinder at the inside end.

The shaft is made of brass and turned in one piece with two grooves. One groove lines up with the screw that stops the inner assembly coming out, and an inner one is for a suitable "O" ring. I found a small  $\frac{1}{2}$ " diameter ring and used this. (At this stage I guessed the groove size but it should be sized appropriately for the size and section selected).

The innermost end is turned down for the PTFE cylinder to be tightly slid into place. Two holes at  $120^\circ$  were drilled to line up with those in the valve body. In order that the PTFE sleeve doesn't turn when the spindle is turned, two pins were put through at each end, still allowing sufficient land to seal in the bore.

Using my rather old and decrepit lathe, I turned these pieces up and assembled the new spindle. (Figure 3)

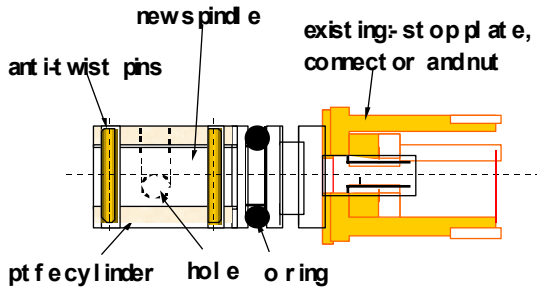

### new spindle assembly

There are only five new pieces:

1. A new spindle
2. A PTFE sleeve
3. Two pins to stop the sleeve turning on the spindle
4. And a suitable "O" ring ( to suit a nominal 1/2" bore.
5. Three of the existing components were used, namely:

The large stop plate (i.e. the disc with a piece on it, the connector to which fits the shaft from the dashboard and the retaining nut.

I had to check that the square on the new shaft was positioned so that the holes lined up then the spindle was twisted, and they

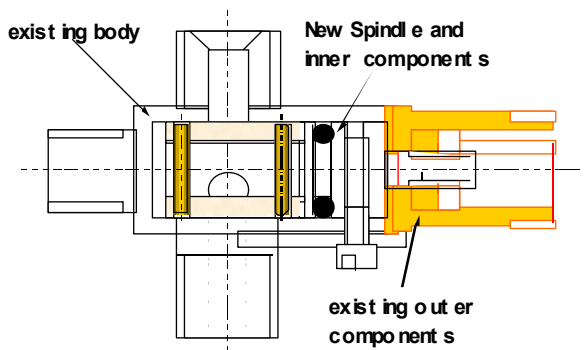

### assembly with new inner components

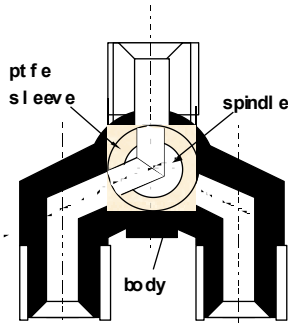

section

The sketches show the nominal dimensions of the components that I made, using measurements that I made from my own valve and shown below.

So far it seems to be working. How many other solutions are out there to this problem?

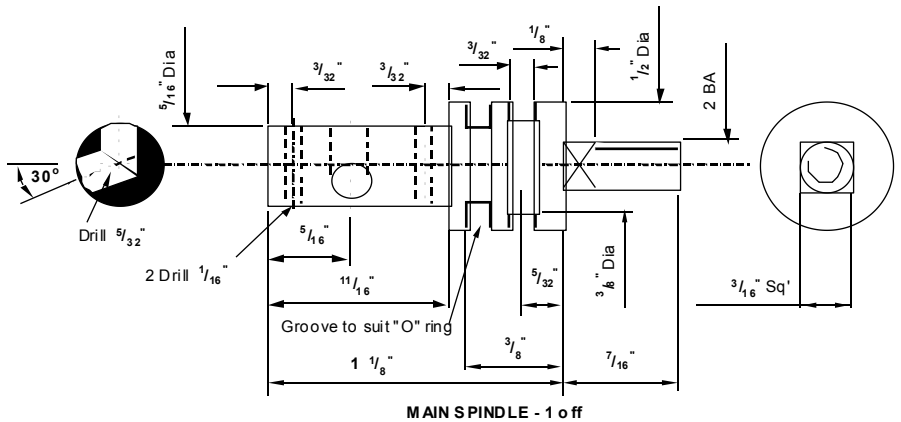

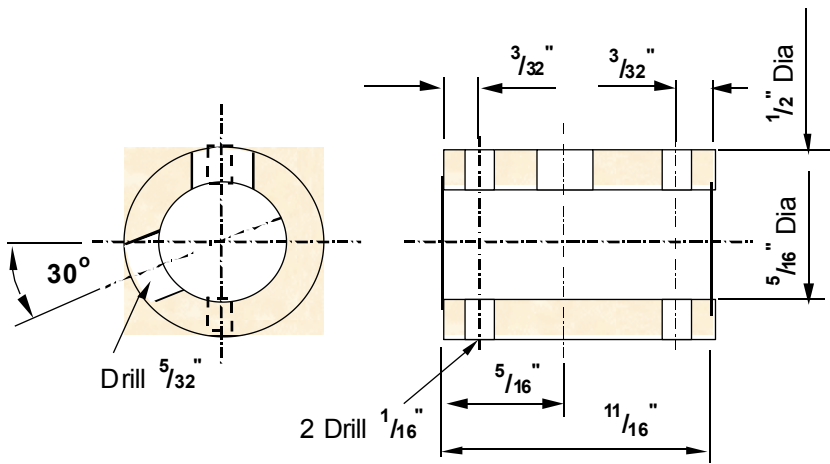

**ROTATING SEAL- 1 off**

## **YOUR LETTERS**

**From Colin Wallace**

Hi Phil

A fitting epitaph for my P-type block for your final edition after the rod smashed through the side, as previously reported in the Bulletin. A sad but useful end to a 77 year old block!

Yours



## **From Bob Milton**

Dear Philip,

Following my article in the Year Book, which highlighted a number of co-incidences in my pursuit of R-types, a further one occurred at the recent 50<sup>th</sup> Anniversary Gala Dinner, which may justify repeating for those that were not there, or indeed those that were and missed the connection.

Our guest speaker at this dinner was the well- known racing driver of historic cars, Barrie Williams, better known as Whizzo Williams. In the course of his speech he told of his early days as an apprentice at the David Brown Gear company in Huddersfield, and remarked that it was here that he enjoyed one of his earliest connections with MG by visiting a guy in Huddersfield who had an R-type MG. I was that guy of course, and all this was in the early '60's, and Barrie at that time was one of many who used to visit me to see the cars. Of course I don't remember the occasion in detail, but it does just add to the co-incidences in my R-type life.

## From John Rogers

Dear Phillip,

I am sure I am not the first, nor the last to say, what a great success the 50th MMM anniversary was, which I feel was due in no small part to the considerable degree of hard work that Elizabeth and her team must have put in. For my part, despite one or two glitches, which were beyond her control, I am very pleased that I put my hand in my pocket and attended. Many thanks to the team. (I have enclosed a photograph you may find of interest.)

Yours



## From Gabriel Ohman

Hello Philip,

Regarding the picture of the disc-wheeled M-type in the Letters section of the last Bulletin, in the 2002 Swedish list of Triple-M cars in the country PJ 3200 (2M 3342) has been here since 1987. In the Triple-M Register list of 2010, you can find the car under its chassis number.

A very nice looking M-type with its wheelspats. Is it the right word, well anyhow it looks very well with these shiny discs.

**2M/3142** 32 2-sviter sports 32.?? ?? Sherlock Jocelyn Humphries (behåller bilen i över 50 år) PJ-3200

Svart med grön skinnklädsel (vilket var den i särklass vanligaste färgkombinationen på M. G. under 30-talet) och med en grön, låbeskrenoverad utbytesmotor. Sälld av förste ägarens dödsbo i mitten av 80-talet till John Guy (vars far förresten förr hade det välkända engelska lastbilsföretaget med samma namn), men snart lämnad till auktion på Christie's i London och då inropad av Tomas Sköld i Bollnäs och hans Rex Collection - Thomas är förresten son till Rune Sköld som tävlade flitigt i bland annat Midnattsrallyt med sin TC. (TC/2147) och TD åren efter kriget och fram till mitten av 50-talet.

87.??.?? Till Sverige: Tomas Sköld, Rex Collection, Museikonst  
 91.12.18 Första reg: Copywriter Stefan Jerget, Brändåsgår 20, 115 35 Sölm  
 92.??.?? Birgitta Casamer, Skägga, Värmdö  
 95.??.?? Par Skogslund, Överbyvägen 15, 811 92 Sandviken.

**PDN 196**



Får är egentligen Austin-Healeyman men har kvar denna M-type som är en nästan helt oskruvad och orörd originalvagn i det sena utförandet med plåka-rosseri och samma "helmet wings" som D-type, F-type och J.I. Förste ägarens, S.J. Humphries, monogram är målat på dörrarna och bilen har kvar sina ursprungliga registreringsskyltar (FJ 3200) och skanskyvittat från 1932. Redan då den var ny modifierades den med bland annat större, kromade tyckor och behållande hjullärläkar i aluminium enligt mottoet "jag är ockes en Delage". 1936 modifierades den hos fabriken Service Department med hydrauliska bromsar, vid något tillfälle fick den en fabriksrenoverad utbytesmotor (kanske tog den första slut under något av alla de klubbträffar i The Vintage Sports-Car Club eller något av de ekonomistävlingar, med reportage i diverse olika tidningar, som Humphries gillade att köra med sina bilar) och 1960 klädde Humphries själv om inredningen i nytt skinn i den gröna originalfärgen. Då försvarstjänst utvärderades de gröna originalfärgerna brukade mte hållas särskilt nog i en liten låda mellan ryggsidet och bagageluckan.

2M/3142 är en mycket sen original-M, dessutom plåtblådd och med till exempel låda-hänsel hjullärläkar av fabrikat Ace, blått tillbehöret. © Stefan Jerget

de pneumatiska sidsidorna, vilka M.G.-bilarna hade vid den här tiden - de uppblåsbara gummibälgen brukade mte hållas särskilt nog i en liten låda mellan ryggsidet och bagageluckan.

I have a picture of Bongazoo taken by me two years ago, down in the southern part of Sweden. Glenn Billquist the then owner has now sold the car to some one in France I believe. It was a very quick car and had very interesting wheels, as it was inner-spoked to make it wider.



*We also had a response from Tony Bugbird who saw the M-type in a rally in the Guildford area back in 1984, when his daughter, Robbie tried it for size. Note the crest on the door - Ed*



## **From Lew Palmer**

Phil,

I am in the process of collecting and scanning old InfoLetters starting with Number 1 (much as I have done with all of the Yearbooks, which are no longer available). Although many of the early ones deal with people seeking or selling spares, I find that there are many good tips contained therein.

As many members have never seen some of the early issues, it

would seem sensible to collect and reprint some of those gems of wisdom.

The PB Airline Coupe (PB0560), which I purchased from the Gerry Goguen collection back in 2000, is finally complete. It has had two outings so far, and will shortly be taken to Kalamazoo, Michigan for the GOF Central 2011. I enclose a current picture. Cheers,



## **TIPS AND HINTS**

*We urgently need more items for this section, so as to enable the many people who read the Bulletin to get the technical information that they subscribe to the Bulletin for. Many people are new to this game and wish to obtain as much information about their cars as possible. So please think about a little dodge or assembly detail that you may have recently done which may help your fellow Triple-M member. Almost as important is a recommendation of a firm who has been of help to you recently – often people are reassured when they*

*recommended by fellow owners; it helps to save people going to a firm which has been less than satisfactory when the firm is picked at random.*

**Ted Hack** writes “We’ve updated the Parts for Sale page on the D-type Group website ([www.mgdgroup.org](http://www.mgdgroup.org)) with some interesting items, including new proper D Type gearbox remote brackets for the control rods which were talked about some years ago. We’ve also updated the Wanted items, as some items had been fulfilled but left up. If your particular ‘want’ is not there please let me know and I’ll include it”.

Recently there has been discussion amongst K-type owners as to the correct location for the petrol change-over tap. It appears that it is fitted centrally on the front of the firewall right behind the engine, so that the change-over rod, that is located in the remote control, can link up with the Y-shaped tap. The two fuel lines come across from the offside where they run up the chassis rail, and the single delivery pipe from the tap then goes to the petrol pump. The change-over tap is supported by an S-shaped bracket fixed to the front of the bulkhead, with the tap sitting between the bracket and the bulkhead.

**Lew Palmer** writes “I am often consulted on the problems associated with issues in the charging systems of Triple-M cars, most often on the J, and the PLC2 Switch. Frequently people find that they are getting no charging except in the headlight position of the ignition/lighting switch. It isn't until we refer to the internal wiring of the PLC2 switch are the problems obvious. Since I have never found a wiring diagram of the 4 position PLC2 switch, I have created my own, which I herewith pass on”.

## PLC SWITCH Internal Wiring

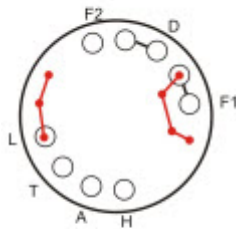

LOW

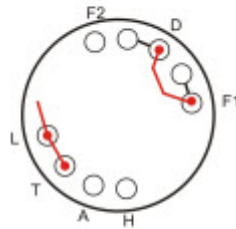

HIGH

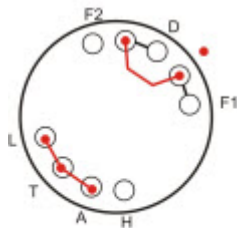

SIDE

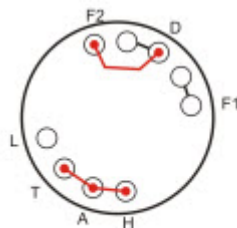

HEAD

**Octagon Originals (1 Richmond Terrace, Garstang Road, Brock, nr Preston, Lancs, PR3 0RB. Tel. 01995 640560, e-mail [ldrichmond@btinternet.com](mailto:ldrichmond@btinternet.com))** had a stand at Silverstone selling original workshop manuals and other memorabilia, so give them a call if you are after something.

When cutting out new gaskets, the easy way to form the bolt holes, is to first locate the hole with two cuts in a cross. Then get a ball bearing slightly bigger than the hole size, position it in the

location of the cross, give it a sharp tap, and it will shear the gasket material cleanly around the hole.

**Martin White** writes “J-types suffered from gearstick rattle; the original fix was to insert a rubber washer inside the gate of the remote control. This was superceded by a spring fitted over the internal part of the lever between the ball and the end of the selector lever. The parts list does not mention the date of the change, but J2948 was retrofitted with the spring in May 1933, which is about halfway through the production period. The gear knob was also changed at some point not specified in the Parts List. It was originally a ball with an octagon around its circumference, but it was later changed to that delightful art deco styled crystal as used on the P-type, except it was black not brown. A guesstimate for the changeover is J3576, when the instruments were restyled. Another item in the gearbox area is the clutch inspection hole cover. J2s had a pressed steel cover, but most now seem to have a cast aluminium cover with the MG logo cast in. this may be an improvement carried out by later owners, but if MG did it, maybe that also occurred with J3576. Can anyone shed any light on this?

Bryan Ditchman has presented the MG Car Club Archivist with an Album containing 100 captioned photographs of Dickie Green’s trialling exploits. The album was put together by Bryan with help from Roger Thomas who wrote the introduction, and prepared the captions

**New website:** [www.mgmmm.com](http://www.mgmmm.com)

Gerard van Putten and Jos Schreuders

How did it come about.....?Four years ago I purchased the remains of a J1 Midget from a well-known dealer of Triple-M cars. Ignoring the dark clouds regarding unobtainable parts, I enthusiastically started the restoration of the car to J2 specification. As this was after an

early retirement from work, I planned to make as many of the missing parts myself.....yes you can buy parts but then someone else has copied the original part, and made it for you, and often it would be "almost right" ! In the meantime I met other Triple-M enthusiasts and asked for their advice regarding parts and techniques for the production of obsolete parts for our cars. Their response was wonderful, and I was able to borrow original parts to produce accurate drawings to enable me to make them myself.

Thus grew the collection of drawings, and I realised that many other enthusiasts were repeating this work, and I decided to make them available to all. With the help of Jos, who was building a J4 replica, but now working on an L2 Magna, we created a website to share all this information with other like-minded Triple-M enthusiasts.

We have titled the website [www.mgmmm.com](http://www.mgmmm.com) and hope that others will join us to share their knowledge and experience, to enable us all to enjoy the restoration and use of our MGs. Photos, drawings, literature, techniques and personal experiences are all welcome. The site has been on line for two years now, and growing all the time. We hope that you will find it of use and that you too have valuable Triple-M information to add to the collection.

We do not intend to compete with the Triple-M Register Forums, as this is an information site to provide accurate information for parts to suit our cars.

Your comments are most welcome,

## **SPARES FOR SALE**

*We do not charge for putting your advert in the spares for sale/wanted, but ask that you send a contribution in the form of a Tip or Hint for that section.*

**Martin White (71 Deepfield Road, Bracknell, Berks, RG12 2NU. Tel. 01344 424258)** has a pair of nice original P-type headlamps; £150. A set of four J2/F2/L2 bonnet catches; £35. Large flat glassed headlamp bowls as used on the K-type etc, too

fitted for chroming but OK for painting; £100. Also a Klaxon horn in working order, as used on J2s; £75.

**David Hammond (189 Tinshill Road, Leeds, LS16 7LD. Tel. 0113 2610638)** has an ND chassis for sale with body etc, also another N-type chassis, both with V5s. A third N-type chassis has not V5 but some history. N-type spares such as camshaft covers, camshafts, cam stands etc. A J2 chassis with V5 and some parts. A set of K1/K3 type brake drums, shoes and backplates (one with a 2" strip missing from edge). Dismantled crosstube ENV gearbox. N and P-type gearboxes and gear sets; one fully rebuilt N-type gearbox with overdrive. OFFERS please.

## **SPARES WANTED**

**Alan McHarg (71 Midton Road, Ayr. KA7 2TW Tel. 01292 281347)** is looking for a complete differential assembly preferably for P or N type. Condition of crown wheel and pinion not too important.

## **CARS FOR SALE**

**David Hammond (189 Tinshill Road, Leeds, LS16 7LD. Tel. 0113 2610638)** has a 1934 Lester-bodied N-type for sale, fitted with a pre-selector gearbox, and currently on carburettors, but side-mounted Marshall blower being currently prepared. OFFERS please

*DISCLAIMER – The opinions expressed in this publication are the personal opinions of the editor, or the contributor, and are in no way the opinion of the Triple-M Register, except where expressly stated. Offers of goods or advice in this Bulletin are given in good faith. All responsibilities as to price, quality of parts, services or advice is a matter entirely between the parties concerned in any transaction. Neither the MG Car Club nor the Triple-M Register can be held responsible in any way for any misrepresentation or failure, nor can they be held to adjudicate in any dispute. In addition, no company or commercial organisation has any connection with the MG Car Club or the Triple-M Register*

**PRESIDENT – MIKE ALLISON**, 5 Fir Tree Lane, Newbury, Berks, RG13 2QX. (Tel.01635 40724. E-mail:Mgmikeallison@talktalk.net

**CHAIRMAN –Peter Green**, Greenacres, Purton Lane, Farnham Royal, Bucks, SL2 3LY. (Tel. 01753 643468 E-mail: [p.green@mgk3.co.uk](mailto:p.green@mgk3.co.uk))

**SECRETARY – George Eagle**, Foxcote Chase, Leckhamstead Road, Akeley, Bucks. MK18 5HG. (Tel. 01280 860428 E-mail: [geaglemg12@dsl.pipex.com](mailto:geaglemg12@dsl.pipex.com))

**TREASURER – Bob Milton**, New Lodge, Bardwell Road, Barningham, Bury St Edmunds, Suffolk, IP31 1DF. (Telephone 01359 221397 E-mail [treborbardbarn@fsmail.net](mailto:treborbardbarn@fsmail.net))

**REGISTRAR – Robin Hamblett**, 21 Rosemary Gardens, Thatcham, Berks, RG18 4BA. (Tel. 01635 292456 E-mail: [robin.hamblett@gmail.com](mailto:robin.hamblett@gmail.com))

**COMPS SECRETARY - Mike Linward**, 18 Victoria Road, Chingford, London. E4 6BZ. (Tel. 0208 529 3241 E-mail: [mikelinward@yahoo.co.uk](mailto:mikelinward@yahoo.co.uk))

**SAFETY FAST SCRIBE – Dick Morbey**, Marlstone, Frieth, Henley on Thames, Oxon, RG9 6PR. (Tel. 01494 883112. E-mail: [richard.morbey@gmail.com](mailto:richard.morbey@gmail.com))

**YEARBOOK EDITOR – Cathelijne Spoelstra**, Havenstraat 44a, 2681 LC Monster, Netherlands. (mobile tel. 0031-6-41216600 E-mai: [info@mgworkshop.nl](mailto:info@mgworkshop.nl))

**YEARBOOK ADVERTS –Elizabeth Taylor**, Oakend, Hazelhurst Road, Burnham, Bucks, SL1 8EE. (Tel. 01628 665055 E-mail: [e.taylor@oakend.net](mailto:e.taylor@oakend.net))

**HISTORIAN – Barry Foster**, Rockes Barn, Butleigh, Glastonbury, Somerset, BB6 8ST. (Tel. 01458 850169 )

**NEW BULLETIN EDITOR – Bob Richards**, 5 Conway Grove, Cheadle, Staffs, ST10 1QG. (Tel. 01538 753010 e-mail [bobr41@talktalk.net](mailto:bobr41@talktalk.net))

**LIBRARIAN – Peter Hemmings**, Folly Farm, Thornford Road, Headley, Berks, RG19 8AH. (Tel. 01635 269260 e-mail: [peter.hemmings@tiscali.co.uk](mailto:peter.hemmings@tiscali.co.uk))

**SUBSCRIPTION CO-ORDINATOR – Paul White**, Rhiwlas, Y Pant, Llan-degla, Denbighshire, LL11 3AE (Tel. 01978 790652 E-mail: [rhiwlas.35@btopenworld.com](mailto:rhiwlas.35@btopenworld.com))



***Rod Ptak's newly restored L-type  
salonette at MG Silverstone***



***The 24 litre Packard Bentley breathing fire at the Brooklands 12/12***



***Frank Ashley's M-type and Peter Tabb with the Jarvis F-type dwarfed by the Vulcan bomber on one of the 50th Anniversary visits***



***Most of the Evans Family trophies on display at the Brooklands Society Reunion***