

5/-

**THE SPARE PARTS  
LIST FOR**

THE



**MAGNETTE**

(N.a. Type)

## FOREWORD

MAY, 1934

The Spare Parts List has been compiled and illustrated to assist as far as possible the correct ordering of replacement parts, and it will be found that the reference numbers on the illustrations correspond with those in the left-hand columns of the spares list.

When ordering replacements it is of the greatest assistance to our Service Department if the part required is given its correct reference number and description, and the chassis and engine numbers should be quoted in all correspondence as well as on the order itself, as delay and misinterpretation of orders are thus avoided.

We would also draw your attention to the fact that you will get quicker service if you place all your orders with our Distributors in your territory, who are holding very adequate stocks of M.G. Spares.

The name and address of the nearest Distributors is given in Instruction Manual supplied with the car, and we feel sure that all your requirements will receive every consideration and attention.

May we request you therefore to get into touch with our Distributors for all your future orders ?

We cannot stress too highly the *danger* of fitting non-genuine M.G. parts.

Unfortunately cases have come to our notice where accidents have actually been caused by this practice, and we strongly advise all M.G. owners to insist and see that for all repairs and replacements only genuine M.G. parts are fitted.

M.G. parts are specially designed and manufactured to withstand the stresses imposed by a high-speed sports car, and we would warn all owners that the fitting of non-genuine parts renders the guarantee *null and void*.

The Company only fit the highest grade and best known proprietary fittings, but we give no guarantee whatsoever in respect of tyres, lamps, electrical equipment, speedometers, clocks, or any other proprietary fittings of any type supplied with the car or otherwise, as such proprietary fittings are usually covered by a guarantee issued by their respective manufacturers.

All questions involving the replacement or repair of any such proprietary fittings should therefore be taken up direct with the manufacturers concerned, and not with The M.G. Car Company Ltd.

G.K.—G.T.



CHASSIS NUMBER.....

ENGINE NUMBER.....

BODY NUMBER.....

REGISTRATION NO.....

NAME.....

ADDRESS.....

.....

DATE.....

AGENT.....

**PLEASE FILL IN AND QUOTE REFERENCES IN  
CORRESPONDENCE AND WHEN ORDERING  
PARTS.**

## INDEX

	PAGE
Accessories and Sundries .. .. .	30
Axle, Front, and Springs .. .. .	5-6
Axle, Rear, Springs and Propeller Shaft .. .. .	6-9
Body Details (Two-seater) .. .. .	34-37
Body Details (Four-seater) .. .. .	37-38
Bonnet, Wings and Fairings .. .. .	33-34
Brake Gear .. .. .	25-26
Chassis Frame and Details .. .. .	2
Controls .. .. .	26
Dashboard and Fume Excluder .. .. .	30
Electrical Equipment and Instruments .. .. .	33
Exhaust System and Silencer .. .. .	29
Petrol Tank and Pipes .. .. .	29
<b>Power Unit and Installation</b> .. .. .	<b>9-25</b>
Bell Housing and Rear Main Bearing .. .. .	10
Clutch Details .. .. .	21
Connecting Rods and Pistons .. .. .	13
Crankshaft, Intermediate Main Bearings and Flywheel .. .. .	10
Cylinder Block .. .. .	9-10
Cylinder Head and Valve Gear .. .. .	13-14
Dynamo and Vertical Drive .. .. .	17
Electrical Details .. .. .	21
Engine Nosepiece and Front Main Bearing .. .. .	10
Gearbox and Remote Control .. .. .	21, 22, 25
Induction Manifold, Carburettors and Exhaust Manifold .. .. .	14
Lubrication Details .. .. .	17-18
Water Pump and Details .. .. .	17
Propeller Shaft Shroud and Fittings .. .. .	34
Radiator and Connections .. .. .	26-29
Spare Wheel Carrier and Fittings.. .. .	34
Steering Gear .. .. .	26
Tool Kit .. .. .	43

**Don't forget to quote Chassis and Engine Numbers.**

Part No.	DESCRIPTION	No. Used		Price Each		
		2-seater	Tourer	£	s.	d.
<b>CHASSIS FRAME AND DETAILS</b>						
MG486	<b>Chassis frame assembly, comprising</b> 2 side members, 7 cross tube assemblies, 2 front and 2 rear dumb-irons, 2 front sliding trunnion brackets, 2 body support channel assemblies, 2 front and 2 rear spring suspension pins, battery carrier, and 2 front and 2 rear brake cable stop brackets .. ..	1	1	21	0	0
MG486/15	<b>Front cross tube assembly</b> .. ..	1	1	8	6	
MG486/1	<b>Engine bearer cross tube assembly</b> .. ..	1	1	1	12	6
MG486/103	Cap for front engine mounting .. ..	1	1	3	7	
MG486/104	Special bolt for ditto .. ..	2	2	1	10	
MG486/2	Brake cross shaft cross tube assembly .. ..	1	1	1	1	10
MG486/3	Rear spring front cross tube assembly .. ..	1	1	1	2	6
MG486/4	Rear body support cross tube assembly .. ..	1	1	2	19	3
MG486/114	Body rear support bracket and Silentbloc housing (outside) .. ..	2	2	13	10	
MG486/116	Ditto (centre) .. ..	1	1	9	10	
S17/1	Silentbloc (outer) .. ..	2	2	8	6	
S17/2	" (centre) .. ..	1	1	5	3	
MG486/5	Rear spring rear cross tube assembly .. ..	1	1	2	15	4
1794	Rear sliding trunnion roller .. ..	4	4	2	9	
820	Washer for ditto .. ..	2	2	6		
873	Distance piece for cross tube .. ..	2	2	11		
1793	Cap for cross tube .. ..	2	2	7	9	
MG486/6	Rear cross tube assembly .. ..	1	1	1	1	3
2629	Blanking-off cap for rear cross tube .. ..	2	2	1	0	
MG486/7	Channel body mounting assembly .. ..	2	2	16	8	
S17/3	Silentbloc for ditto .. ..	4	4	5	3	
MG486/122	Side member O/S .. ..	1	1	2	1	8
MG486/123	" " N/S .. ..	1	1	2	1	8
MG486/124	Front dumb-iron O/S .. ..	1	1	8	6	
MG486/125	" " N/S .. ..	1	1	8	6	
MG486/8	Front spring sliding trunnion bracket assembly O/S ..	1	1	13	0	
MG486/126	Front spring sliding trunnion bracket O/S .. ..	1	1	7	9	
MG486/128	Cover for ditto .. ..	1	1	2	1	
1771	Front spring sliding trunnion roller .. ..	2	2	2	9	
MG486/9	Front spring sliding trunnion bracket assembly N/S ..	1	1	13	0	
MG486/127	Front spring sliding trunnion bracket N/S .. ..	1	1	7	9	
MG486/128	Cover for ditto .. ..	1	1	2	1	
1771	Front spring sliding trunnion roller .. ..	2	2	2	9	
MG486/10	Body mounting suspension bracket assembly O/S .. ..	1	1	10	4	
MG486/129	Body mounting suspension bracket O/S .. ..	1	1	5	3	
MG486/131	Body mounting suspension bracket pin .. ..	1	1	4	5	
MG486/142	Special washer for ditto .. ..	1	1	10		
MG486/11	Body mounting suspension bracket assembly N/S .. ..	1	1	10	4	
MG486/130	Body mounting suspension bracket N/S .. ..	1	1	5	3	
MG486/131	Body mounting suspension bracket pin .. ..	1	1	4	5	
MG486/142	Special washer for ditto .. ..	1	1	10		
MG486/13	Rear spring front suspension bracket assembly O/S ..	1	1	1	0	10
MG486/132	Combined body and rear spring suspension bracket O/S .. ..	1	1	16	0	
MG486/131	Body mounting suspension bracket pin .. ..	1	1	4	5	
MG486/142	Special washer for ditto .. ..	1	1	10		
MG486/14	Rear spring front suspension bracket assembly N/S ..	1	1	1	0	10
MG486/133	Combined body and rear spring suspension bracket N/S .. ..	1	1	16	0	
MG486/131	Body mounting suspension bracket pin .. ..	1	1	4	5	
MG486/142	Special washer for body mounting suspension bracket pin .. ..	1	1	10		
MG486/134	Battery carrier .. ..	1	1	6	0	
1780	Rear spring rear cross tube end bracket .. ..	2	2	2	9	
1765	Front spring suspension pin .. ..	2	2	2	6	
804	Rubber buffer and plate (front axle stop) .. ..	2	2	1	7	
805	Backing plate for ditto .. ..	2	2	4		
815	Rear axle striking pad .. ..	2	2	3		
817	Set screw for ditto .. ..	2	2	2		
2912	Rear engine bearer and brake pedal bracket .. ..	1	1	4	8	
2917	Rear engine bearer bracket N/S .. ..	1	1	7	10	
959	Location screw for ditto .. ..	1	1	1	3	
874	Combined greaser and set screw .. ..	2	2	10		

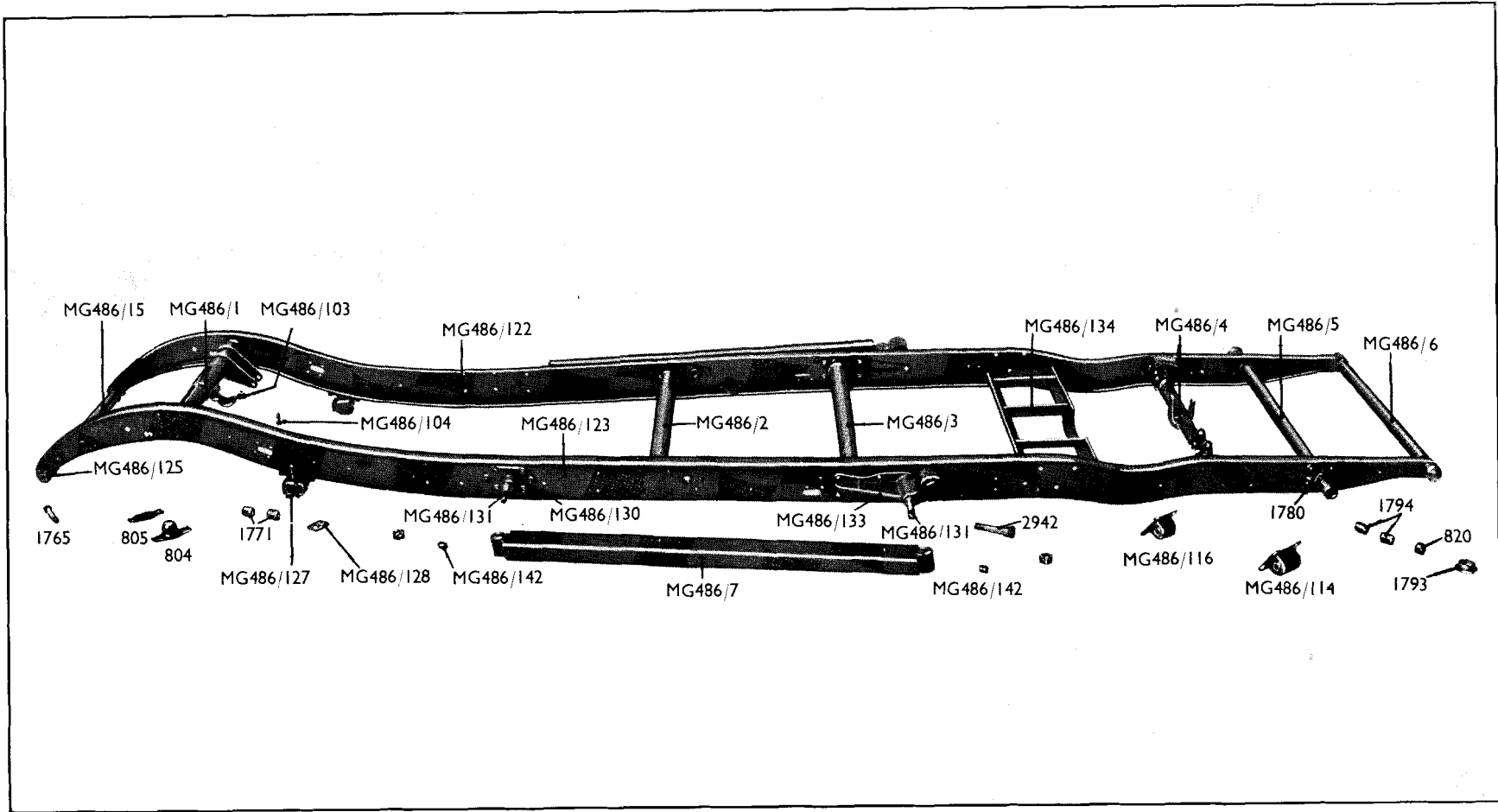



Part No.	DESCRIPTION	MG		Price Each		
		2-seater	Tonnet	£	s.	d.
<b>FRONT AXLE ASSEMBLY AND SPRINGS</b>						
MG502	<b>Front axle assembly less springs and wheels</b> .. .. .	1	1	13	10	0
MG502/100	Axle beam .. .. .	1	1	2	6	6
MG502/1	Steering knuckle with bushes O/S .. .. .	1	1	18	0	0
MG502/2	" " " " " N/S .. .. .	1	1	18	0	0
MG502/103	Bush for steering knuckle (top) .. .. .	2	2	1	10	0
MG502/104	Bush for ditto (bottom) .. .. .	2	2	1	6	0
P101/113	Slotted nut for ditto (R.H. thread) .. .. .	1	1	1	0	0
P101/114	" " " " " (L.H. thread) .. .. .	1	1	1	0	0
P101/115	Washer for ditto (wheel bearings) .. .. .	2	2	doz.	9	0
MG493/109	Steering arm O/S .. .. .	1	1	7	6	0
MG493/110	" " " " " N/S .. .. .	1	1	7	6	0
MG502/101	Steering knuckle king pin .. .. .	2	2	2	5	0
MG374/1	Cotter pin for ditto .. .. .	2	2	1	2	0
X101/1	Nut for ditto .. .. .	2	2	doz.	1	3
X101/2	Spring washer for ditto .. .. .	2	2	doz.	8	0
MG502/109	Front axle swivel stop screw .. .. .	2	2	2	3	0
MG502/110	Tab washer for ditto .. .. .	2	2	doz.	1	0
MG502/106	Thrust washer for king pin .. .. .	2	2	1	0	0
MG502/107	Disc for steering knuckle top bush .. .. .	2	2	doz.	1	0
MG365/2	Brake anchor bracket assembly O/S .. .. .	1	1	1	4	10
MG365/3	" " " " " N/S .. .. .	1	1	1	4	10
MG365/118	" Bush for brake cam bracket .. .. .	2	2	1	6	0
X234/2	Bolt for brake anchor bracket (1 $\frac{1}{16}$ " long) .. .. .	4	4	3	0	0
X502/1	" " " " " (2 $\frac{5}{16}$ " long) .. .. .	2	2	11	0	0
X502/2	" " " " " (2 $\frac{3}{8}$ " long) .. .. .	2	2	1	0	0
X101/10	Nut for ditto .. .. .	8	8	doz.	1	3
X101/11	Spring washer for ditto .. .. .	8	8	doz.	8	0
MG365/109	Brake cam O/S .. .. .	1	1	3	0	0
MG365/107	" " " " " N/S .. .. .	1	1	3	0	0
MG365/104	Brake cam lever O/S .. .. .	1	1	3	0	0
MG365/103	" " " " " N/S .. .. .	1	1	3	0	0
X101/4	Key for brake cam .. .. .	2	2	3	0	0
X101/5	Bolt for brake cam lever .. .. .	2	2	3	0	0
X101/1	Nut for ditto .. .. .	2	2	doz.	1	3
X101/2	Spring washer for ditto .. .. .	2	2	doz.	8	0
MG365/4	Brake-shoe with linings .. .. .	4	4	13	7	0
MG365/105	Brake-shoe lining .. .. .	4	4	3	0	0
X493/3	Rivets for ditto .. .. .	36	36	doz.	6	0
MG362/157	Spring for brake-shoe .. .. .	2	2	3	0	0
574	Damper weight for brake-shoe .. .. .	4	4	2	0	0
576	Clevis pin .. .. .	8	8	3	0	0
575	Spring for ditto .. .. .	8	8	3	0	0
X101/12	Washer for ditto .. .. .	16	16	doz.	8	0
MG493/111	Fulcrum pin for brake-shoe .. .. .	4	4	11	0	0
X493/4	Nut for ditto .. .. .	4	4	2	0	0
X365/2	Spring washer for ditto .. .. .	4	4	doz.	8	0
MG493/3	Front hub with studs O/S .. .. .	1	1	18	10	0
MG493/4	" " " " " N/S .. .. .	1	1	18	10	0
P234/103	Hub studs .. .. .	12	12	9	0	0
X234/1	Nut for ditto .. .. .	12	12	doz.	10	0
X101/11	Spring washer for ditto .. .. .	12	12	doz.	8	0
MG493/106	Oil retainer for front hub .. .. .	2	2	3	0	0
MG493/104	Distance washer for ditto .. .. .	2	2	6	0	0
P101/116	Hub bearing (large) .. .. .	2	2	10	6	0
P101/110	Distance piece for hub bearing .. .. .	2	2	1	0	0
P101/117	Hub bearing (small) .. .. .	2	2	10	9	0
MG493/5	Brake-drum .. .. .	2	2	1	14	10
P101/112	Countersunk screw for ditto .. .. .	4	4	doz.	1	0
S1/8	Stauffer grease cup .. .. .	2	2	9	0	0
2324	Grub screw for brake back plate .. .. .	2	2	doz.	1	3
MG502/3	Track rod assembly .. .. .	1	1	18	6	0
MG502/4	Track rod tube .. .. .	1	1	8	0	0
P101/136	Lock nut for track rod tube (R.H. thread) .. .. .	1	1	4	0	0
P101/137	" " " " " (L.H. thread) .. .. .	1	1	4	0	0
P101/140	Adjustable end for ball joint (R.H. thread) .. .. .	1	1	5	6	0
P101/141	" " " " " (L.H. thread) .. .. .	1	1	5	6	0
P101/144	Spring for ball joint .. .. .	2	2	3	0	0
P101/142	Ball cup (inner) .. .. .	2	2	10	0	0
P101/143	End plug for ball joint .. .. .	2	2	1	0	0
P101/138	Steering ball .. .. .	2	2	2	0	0
P101/139	Nut for ditto .. .. .	2	2	4	0	0
MG511	<b>Draglink assembly</b> .. .. .	1	1	17	2	0
MG511/1	Draglink tube .. .. .	1	1	5	0	0
P102/102	Adjustable end for ball joint (R.H. thread) .. .. .	1	1	5	6	0
P101/141	" " " " " (L.H. thread) .. .. .	1	1	5	6	0
P101/136	Lock nut for ditto (R.H. thread) .. .. .	1	1	4	0	0
P101/137	" " " " " (L.H. thread) .. .. .	1	1	4	0	0





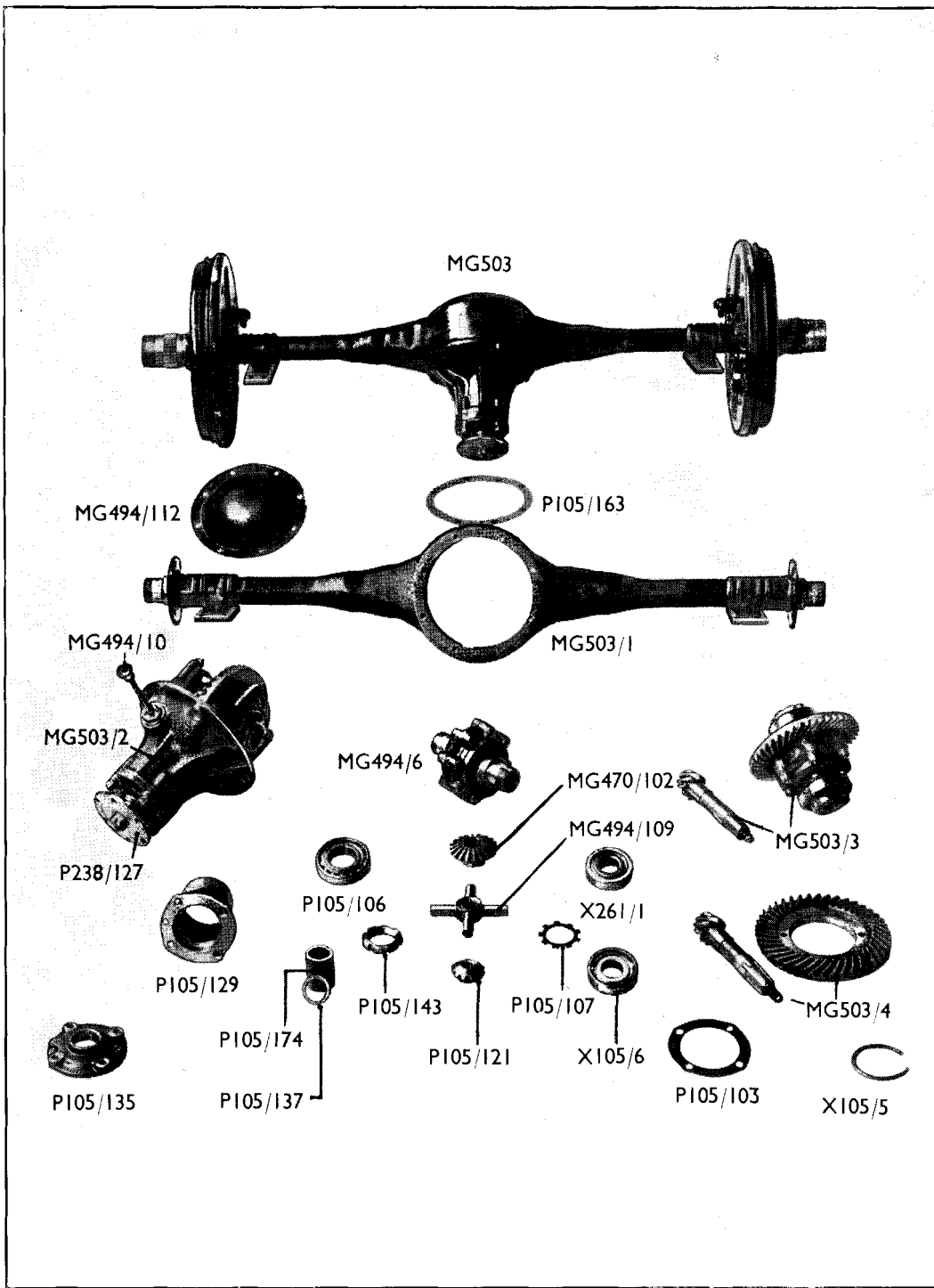

**Always quote Chassis and Engine Numbers in correspondence and when ordering Replacement Parts.**

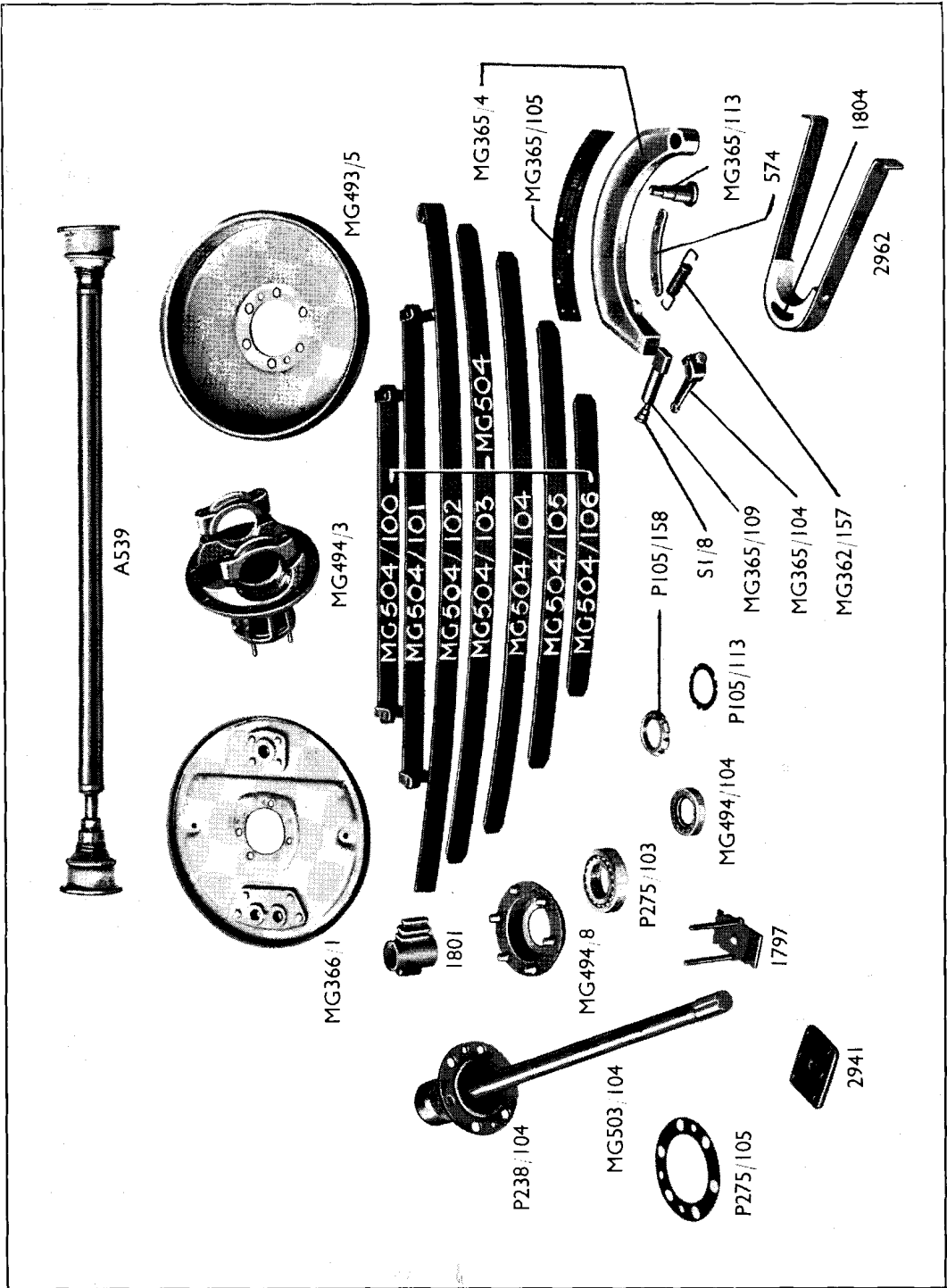

Don't forget to quote the Chassis and Engine Numbers.

Part No.	DESCRIPTION	No. Used		Price Each		
		2-seater	Tourer	£	s.	d.
MG503/104	Rear axle shaft .. .. .	2	2	19	6	
P238/103	Rear hub (R.H.) .. .. .	1	1	14	6	
P238/104	" " (L.H.) .. .. .	1	1	14	6	
MG366/1	Brake anchor bracket assembly O/S .. .. .	1	1	1	4	10
MG366/2	" " " " N/S .. .. .	1	1	1	4	10
MG365/118	" Bush for brake cam bracket .. .. .	2	2	1	6	
X105/8	Bolt for brake anchor bracket (top) .. .. .	4	4			3
X234/2	Bolt for ditto (bottom) .. .. .	4	4			3
X101/10	Nut for ditto .. .. .	8	8	doz.	1	3
MG493/111	Fulcrum pin for brake-shoe .. .. .	4	4			11
X493/4	Nut for ditto .. .. .	4	4			2
X365/2	Spring washer for ditto .. .. .	4	4	doz.		8
MG365/109	Brake cam O/S .. .. .	1	1	3	0	
MG365/107	" " N/S .. .. .	1	1	3	0	
MG365/104	Brake cam lever O/S .. .. .	1	1	3	0	
MG365/103	" " " " N/S .. .. .	1	1	3	0	
X101/4	Key for brake cam .. .. .	2	2			3
X101/5	Bolt for brake cam lever .. .. .	2	2			3
X101/1	Nut for ditto .. .. .	2	2	doz.	1	3
X101/2	Spring washer for ditto .. .. .	2	2	doz.		8
MG365/4	Brake-shoe with linings .. .. .	4	4			13
MG365/105	Lining for brake-shoe .. .. .	4	4			3
X493/3	Rivets for ditto .. .. .	36	36	doz.		6
MG362/157	Spring for brake-shoe .. .. .	2	2			3
574	Damper weight for ditto .. .. .	4	4			2
576	Clevis pin for ditto .. .. .	8	8			3
575	Spring for damper weight .. .. .	8	8			3
X101/12	Washer for ditto .. .. .	16	16	doz.		8
MG494/8	Rear hub bearing housing with studs .. .. .	2	2			8
P238/105	Studs for rear hub bearing housing .. .. .	12	12			9
X234/1	Nut for ditto .. .. .	12	12	doz.		10
X101/11	Spring washer for ditto .. .. .	12	12	doz.		8
P275/105	Joint for bearing housing .. .. .	2	2			3
MG494/104	Oil retainer for rear hub .. .. .	2	2			3
P275/103	Rear hub ball bearing .. .. .	2	2	1	4	0
P105/113	Locking washer for ditto .. .. .	2	2			3
P105/158	Nut for ditto (R.H. thread) .. .. .	1	1			1
P105/159	" " " (L.H. thread) .. .. .	1	1			1
MG493/5	Brake-drum .. .. .	2	2	1	14	10
MG470/105	Countersunk screw for ditto .. .. .	4	4			2
S1/8	Stauffer grease cup for brake camshaft .. .. .	2	2			9
2324	Grub screw for brake back plates .. .. .	2	2	doz.	1	3
MG504	<b>Rear springs O/S and N/S</b> .. .. .	2	2	1	18	3
MG504/100	Rear spring top rebound leaf .. .. .	2	2			4
MG504/101	Rear spring 2nd rebound leaf .. .. .	2	2			9
MG504/102	Rear spring main plate .. .. .	2	2	1	5	6
MG504/103	Rear spring 2nd plate .. .. .	2	2			4
MG504/104	Rear spring 3rd plate .. .. .	2	2			8
MG504/105	Rear spring 4th plate .. .. .	2	2			0
MG504/106	Rear spring 5th plate .. .. .	2	2			5
S17/3	Silentbloc .. .. .	2	2			5
1797	Rear spring top plate .. .. .	2	2			7
2941	Rear spring bottom plate .. .. .	2	2			8
2942	Rear spring suspension pin .. .. .	2	2			7
1805	Rear spring bolts .. .. .	8	8			8
2303	Stiffening strip for rear spring .. .. .	4	4			1
1801	Dust excluder for rear spring .. .. .	2	2			2
2962	Rear axle strap .. .. .	2	2			8
1804	Rubber block for ditto .. .. .	2	2			10
A539	Propeller shaft .. .. .	1	1	2	7	8
811	Propeller shaft flange bolts .. .. .	12	12			4
<b>POWER UNIT AND INSTALLATION</b> (Illustrations, Pages 11-23)						
MG489	<b>Power unit complete with gearbox and remote control</b> .. .. .	1	1	<b>Price on application</b>		
<b>CYLINDER BLOCK</b>						
MG489/1	Cylinder block (studded) with cover-plates .. .. .	1	1	10	12	6
X110/38	Cylinder block core disc .. .. .	2	2			4
MG348/102	Cylinder jacket cover-plate (front and rear) .. .. .	2	2			1
MG348/1	Cylinder jacket cover-plate (intermediate) .. .. .	1	1			6
X363/19	Stud for water pipe (2 $\frac{3}{4}$ " long) .. .. .	1	1			3
X287/5	Stud for ditto (1 $\frac{3}{16}$ " long) .. .. .	1	1	doz.	1	6
MG348/297	Joint for ditto .. .. .	3	3			4
X110/4	Set screw (securing) for ditto .. .. .	18	18			3
X110/5	Washer for ditto .. .. .	18	18	doz.		4
P287/107	Drain cock .. .. .	1	1			1
X287/4	Washer for ditto (fibre) .. .. .	1	1	doz.		4

Part No.	DESCRIPTION	No. Used		Price Each		
		2-seater	Tourer	£	s.	d.
X348/2	Stud for cylinder head ( $4\frac{9}{16}$ " long)	1	1	1	9	
X348/3	" " " " ( $4\frac{1}{16}$ " long)	1	1	1	9	
X348/4	" " " " ( $5\frac{1}{16}$ " long)	1	1			5
X348/5	" " " " ( $4\frac{13}{16}$ " long)	7	7			5
X348/6	" " " " ( $4\frac{1}{16}$ " long)	8	8			5
X110/93	Locating dowel for front bearing housing	1	1			doz. 9
X348/26	Stud for oil drain pipe (centre and rear)	4	4			doz 1 0
X489/6	" for oil base ( $4\frac{3}{8}$ " long)	6	6			4
X489/7	" " " " ( $4\frac{1}{4}$ " long)	8	8			4
X489/9	" for oil filter case (2" long)	4	4			2
X348/8	" " " " ( $1\frac{1}{16}$ " long)	2	2			doz. 1 0
<b>BELL HOUSING AND REAR MAIN BEARING</b>						
MG489/2	Bell housing with rear main bearing	1	1	2	1	6
MG348/178	Rear main bearing bush	1	1	11		9
X110/13	Grub screw for ditto	1	1			2
MG348/100	Bolt (bell housing to cylinder block)	9	9			8
X105/4	Spring washer for ditto	6	6			doz. 8
X239/4	Copper washer for ditto	3	3			doz. 6
MG489/115	Bell housing joint	1	1			2
<b>FRONT MAIN BEARING HOUSING WITH ENGINE NOSE PIECE</b>						
MG489/3	Front bearing housing with front main bearing (bush)	1	1	3	0	6
MG420/101	Front main bearing (bush)	1	1	14		8
MG348/179	Grub screw for ditto	1	1			10
MG348/253	Front bearing housing joint (.006")		as req.			3
MG489/205	" " " " (.010")		as req.			4
X110/11	Set screw (housing to cylinder block)	7	7			3
X105/4	Spring washer for ditto	7	7			doz. 8
MG489/4	Engine nose piece and front bearing housing cover	1	1	1	17	2
X363/13	Bolt for ditto	4	4			3
X105/4	Spring washer for ditto	4	4			doz. 8
X110/11	Set screw for ditto (securing)	4	4			3
X105/4	Spring washer for ditto	4	4			doz. 8
MG348/251	Front bearing housing cover joint	1	1			doz. 1 0
2910	Rubber bush for engine mounting	2	2			1 1
<b>CRANKSHAFT, INTERMEDIATE MAIN BEARINGS AND FLYWHEEL</b>						
MG489/34	Crankshaft (with plugs)	1	1	8	11	3
MG348/143	Plug for crankpin (short)	2	2			6
MG348/144	" " " (long)	3	3			7
X110/23	Key for crankshaft (distributor drive gear)	2	2			3
X348/17	" " " (dynamo drive gear)	1	1			2
MG489/116	Crankshaft flange	1	1	1	1	0
MG348/145	Nut for crankshaft flange (ceased )	1	1			1 9
MG489/202	" " " " (commenced )	1	1			1 9
X110/24	Key for ditto	1	1			6
MG348/181	Thrust washer (rear) for ditto	1	1			1 6
MG348/273	" " (front) for ditto	1	1			1 6
MG348/272	Thrust ring for ditto	1	1			1 6
X348/14	Grub screw for ditto	1	1			doz. 9
MG489/117	Crankshaft spiral gear	1	1	11		1
MG348/128	Crankshaft fan pulley	1	1			5 3
P110/265	Nut (starting dog) for crankshaft	1	1			2 4
MG348/28	Intermediate main bearing (rear) (top and bottom halves)	1	1	2	2	10
X287/7	Bolt for ditto ( $1\frac{3}{16}$ " long)	2	2			4
X105/3	Nut for ditto	2	2			doz. 1 3
X105/4	Spring washer for ditto	2	2			doz. 8
MG348/27	Intermediate main bearing (front) (top and bottom halves)	1	1	1	17	9
X287/7	Bolt for ditto ( $1\frac{3}{16}$ " long)	2	2			4
X105/3	Nut for ditto	2	2			doz. 1 3
X105/4	Spring washer for ditto	2	2			doz. 8
P287/115	Bolt for ditto ( $6\frac{3}{8}$ " long)	4	4			1 5
MG348/300	Lock plate for ditto	4	4			3
MG489/118	Flywheel	1	1	1	9	6
MG348/148	Bolt for ditto	8	8			7
X363/31	Nut for ditto	8	8			3
MG489/119	Spigot bearing housing for 1st motion shaft	1	1			7 0
X110/28	Ball bearing for ditto	1	1			8 9

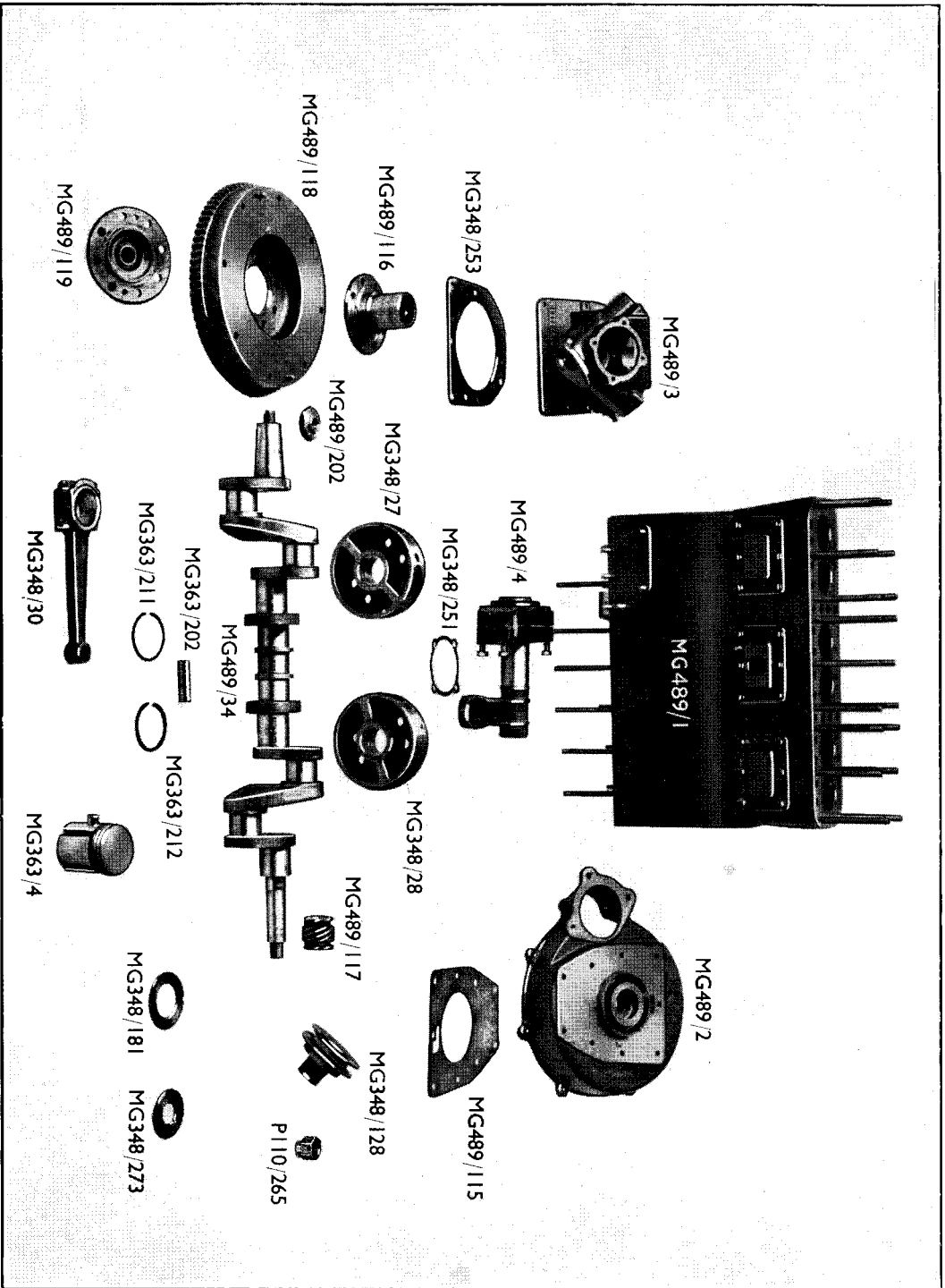

When ordering Parts be sure they are genuine M.G.



Part No.	DESCRIPTION	2-seater		Tourer		Price Each		
						£	s.	d.
<b>CONNECTING RODS AND PISTONS</b>								
MG348/30	Connecting rod with cap and bolts .. .. .	6	6	1	4	10		
MG363/205	Connecting rod bush (small-end) .. .. .	6	6	1	2			
MG384/121	Bolt for connecting rod .. .. .	12	12			10		
984	Nut for ditto .. .. .	12	12			3		
MG363/4	Piston complete with rings and gudgeons	6	6	1	0	0		
MG363/211	Piston rings (compression) .. .. .	12	12			1	3	
MG363/212	" " (scraper) .. .. .	6	6			1	4	
MG363/202	Gudgeon pin with pads .. .. .	6	6			2	4	
<b>CYLINDER HEAD AND DETAILS</b>								
MG489/5	Cylinder head assembly complete (less manifolds and sparking plugs) .. .. .	1	1	22	10	0		
MG489/6	Cylinder head (studded) with valve guides .. .. .	1	1	7	8	9		
MG489/120	Valve guide .. .. .	12	12	1	2			
X110/100	Studs for cylinder head cover .. .. .	6	6			2		
X110/6	Studs for camshaft front bearing housing (securing) (1" long) .. .. .	2	2			3		
X348/21	Studs for camshaft intermediate and rear bearing housing (3 $\frac{13}{16}$ " long) .. .. .	3	3			2		
X110/6	Ditto (1" long) .. .. .	6	6			3		
X110/54	Stud for induction manifold (securing) (1" long)	2	2			3		
X489/1	" " " " (securing) (2 $\frac{3}{8}$ " long)	2	2			2		
X489/2	" " " " (securing) (2 $\frac{15}{16}$ " long)	3	3			2		
X420/4	Stud for exhaust manifold .. .. .	8	8			2		
X110/20	Stud for water outlet pipe .. .. .	6	6			3		
X110/6	Stud for camshaft driving pinion and oil drain housing .. .. .	4	4			3		
X468/10	Stud for cylinder head front flange .. .. .	2	2			3		
X110/38	Core disc .. .. .	3	3			4		
X489/3	Plug for oil gallery .. .. .	1	1			3		
X348/37	Washer for ditto .. .. .	1	1	doz.		1	0	
X101/10	Nuts for cylinder head stud .. .. .	18	18	doz.		1	3	
MG489/121	Inlet valve .. .. .	6	6			3	0	
MG489/122	Exhaust valve .. .. .	6	6			3	0	
1016	Valve spring (outer) .. .. .	12	12			8		
1015	Valve spring (inner) .. .. .	12	12			5		
MG489/123	Collar for valve spring .. .. .	12	12			8		
P110/184	Split cotter for valves (halves) .. .. .	24	24	pair		1	0	
992	Valve-rocker .. .. .	12	12			7	2	
997	Locking screw for valve rocker .. .. .	12	12			2		
MG363/106	Eccentric bush for valve rocker .. .. .	12	12			3	4	
X363/11	Spring ring for valve rocker .. .. .	12	12	doz.		9		
MG348/24	Valve rocker-shaft N/S .. .. .	1	1			4	2	
MG348/23	" " O/S .. .. .	1	1			4	2	
X110/47	Locking screw for ditto .. .. .	6	6			3		
X110/48	Copper washer for ditto .. .. .	6	6	doz.		3		
MG348/182	Distance tube (1 $\frac{27}{32}$ " long) for ditto .. .. .	4	4			5		
MG489/124	" " (1 $\frac{33}{32}$ " long) for ditto .. .. .	4	4			4		
MG489/125	" " (1 $\frac{11}{16}$ " long) for ditto .. .. .	4	4			4		
P110/179	" " (1 $\frac{3}{8}$ " long) for ditto .. .. .	6	6			4		
MG348/185	Belleville washer for ditto .. .. .	12	12	doz.		9		
X287/14	Plain washer for ditto .. .. .	2	2	doz.		6		
MG348/186	Steady bracket for ditto .. .. .	2	2			1	9	
MG348/119	Rear end support bracket for ditto .. .. .	1	1			12	10	
P287/145	Plug for ditto .. .. .	2	2			3		
X110/48	Washer for plug (copper) .. .. .	2	2	doz.		3		
MG489/114	Camshaft .. .. .	1	1	2	3	2		
X363/31	Slotted nut for camshaft .. .. .	1	1			3		
X348/25	Washer for ditto .. .. .	1	1	doz.		6		
2362	Tachometer drive adaptor .. .. .	1	1			2	10	
MG348/19	Camshaft front bearing housing (with cap) .. .. .	1	1			19	4	
X110/49	Dowel for cap .. .. .	2	2	doz.		8		
X348/26	Stud for ditto .. .. .	2	2	doz.		1	0	
X101/1	Nut for ditto .. .. .	2	2	doz.		1	3	
X101/2	Washer for ditto .. .. .	2	2	doz.		8		
P287/145	Plug for cap .. .. .	1	1			3		
MG348/175	Camshaft front bearing (white metal) (top)	2	2			1	0	
MG348/176	Ditto (white metal) (front bottom) .. .. .	1	1			1	0	
MG348/177	Ditto (white metal) (rear bottom) .. .. .	1	1			1	0	
X101/1	Camshaft front bearing housing stud nut .. .. .	2	2	doz.		1	3	
X101/2	Washer for ditto .. .. .	2	2	doz.		8		
MG348/20	Camshaft intermediate and rear bearing housing with cap	3	3			14	6	
X110/49	Dowel for cap .. .. .	6	6	doz.		8		
X348/26	Stud for ditto .. .. .	3	3	doz.		1	0	
X101/1	Nut for ditto .. .. .	3	3	doz.		1	3	
X101/2	Washer for ditto .. .. .	3	3	doz.		8		
P287/145	Plug for cap .. .. .	3	3			3		







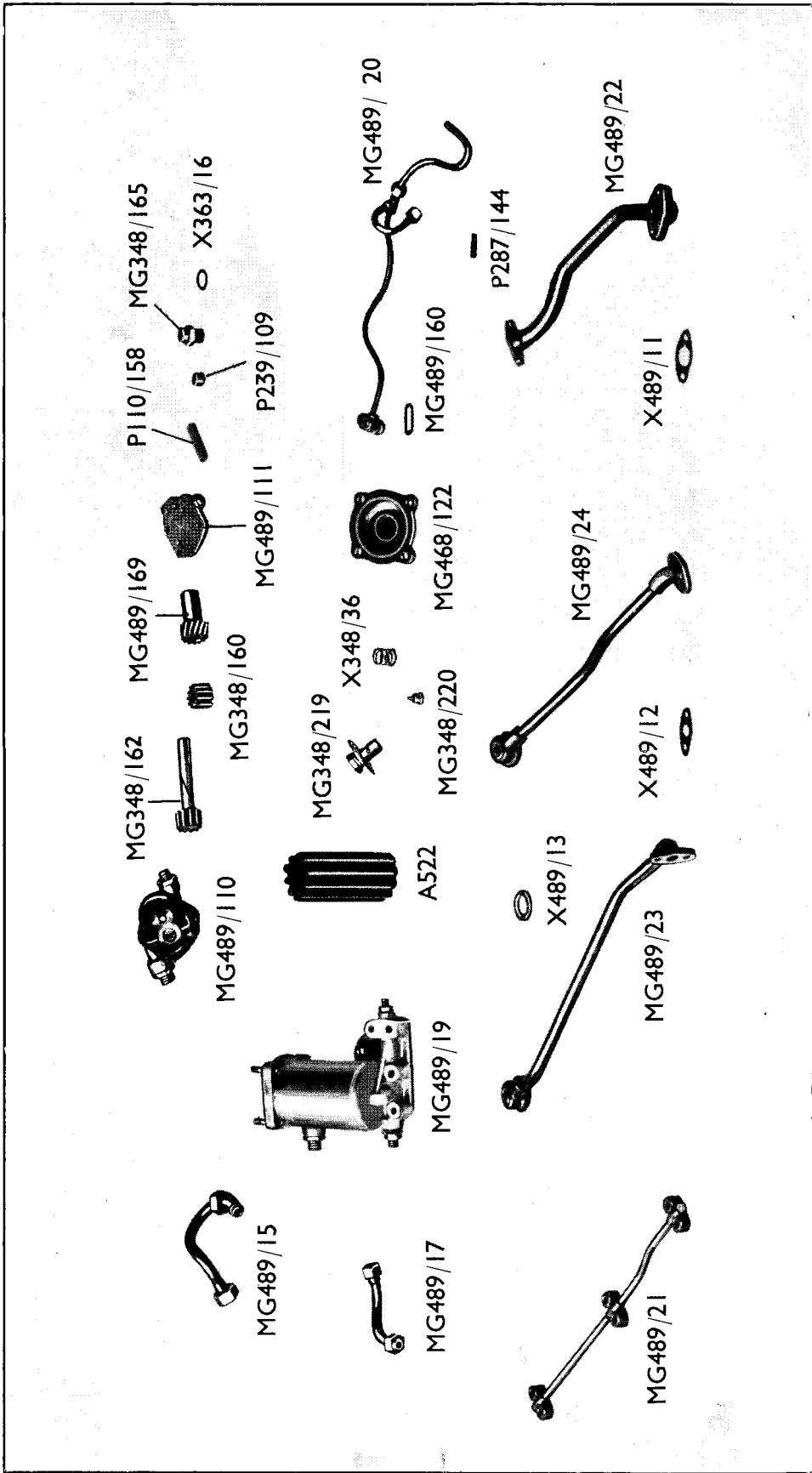

Part No.	DESCRIPTION	No. Used		Price Each		
		2-seater	Tourer	£	s.	d.
<b>DYNAMO AND VERTICAL DRIVE</b>						
X468/5	Copper washer for dynamo spindle (.010" thick) ..	1	1			2
MG468/7	Universal joint fork with oil thrower for dynamo ..	1	1			6 6
P110/4	Dynamo coupling .. .. .	1	1			5 6
P110/282	Packing washer for dynamo coupling (.010" thick) As required			doz.		1 4
P110/283	Ditto (.020" thick) .. .. .			As required	doz.	1 4
P110/284	Ditto (.030" thick) .. .. .			As required	doz.	1 4
P110/285	Ditto (.040" thick) .. .. .			As required	doz.	1 4
P110/286	Ditto (.050" thick) .. .. .			As required	doz.	1 4
P110/277	Bolt for dynamo coupling .. .. .	4	4			6
X101/1	Nut for ditto .. .. .	4	4	doz.		1 3
X101/2	Spring washer for ditto .. .. .	4	4	doz.		8
MG489/204	Shim for dynamo bottom bevel wheel (.010" thick) As required					7
P110/257	Shim for dynamo base (.003") .. .. .			As required		4
P110/258	" " " " (.005") .. .. .			As required		4
P110/259	" " " " (.007") .. .. .			As required		5
P110/260	" " " " (.015") .. .. .			As required		7
MG348/276	Shim for crankshaft bevel wheel (.003") ..			As required		3
MG348/277	" " " " (.005") .. .. .			As required		3
MG348/278	" " " " (.007") .. .. .			As required		3
X105/14	Set screw for securing dynamo .. .. .	4	4			3
X101/2	Spring washer for ditto .. .. .	4	4	doz.		8
A484	Dynamo complete with nuts .. .. .	1	1			10 0 0
MG468/8	Crankshaft and dynamo bevel wheels .. ..	1 pr.	1 pr.	pair		1 13 2
MG468/114	Tab washer for dynamo bottom bevel .. ..	1	1	doz.		1 2
<b>WATER PUMP AND DETAILS</b>						
MG489/11	Water pump assembly .. .. .	1	1			2 7 10
MG348/35	Water pump body (studded) .. .. .	1	1			16 1
X110/101	Stud for water pump cover (1 <sup>5</sup> / <sub>16</sub> " long) ..	4	4	doz.		1 0
X348/18	" " " " (2" long) .. .. .	2	2	doz.		1 0
MG348/109	Cover for water pump .. .. .	1	1			6 8
MG348/255	Joint for ditto .. .. .	1	1			2
X101/1	Nut for ditto .. .. .	6	6	doz.		1 3
X101/2	Spring washer for ditto .. .. .	6	6	doz.		8
MG489/140	Water pump adaptor .. .. .	1	1			8 3
1309	Felt retainer for ditto .. .. .	1	1			10 0
1310	Felt for ditto .. .. .	1	1			2
MG348/152	Water pump spindle .. .. .	1	1			11 4
MG348/153	Slip washer for ditto .. .. .	1	1			1 8
MG489/141	Water pump pinion .. .. .	1	1			7 0
X110/43	Key for ditto .. .. .	1	1			3
MG348/151	Water pump rotor .. .. .	1	1			4 2
1318	Bolt for securing rotor .. .. .	1	1			2
1319	Tab washer for ditto .. .. .	1	1			2
1315	Bush for water pump spindle .. .. .	1	1			1 2
1317	Gland nut for water pump spindle .. .. .	1	1			2 7
1316	Packing for ditto .. .. .	1	1			1 0
X420/6	Spring for ditto .. .. .	1	1			3
X348/12	Bolt for securing water pump body .. .. .	2	2			2
X105/4	Spring washer for ditto .. .. .	2	2	doz.		8
MG348/2	Water inlet pipe .. .. .	1	1			10 10
X105/3	Nut for securing ditto .. .. .	2	2	doz.		1 3
X105/4	Spring washer for ditto .. .. .	2	2	doz.		8
MG348/298	Water inlet pipe hose (2" long) .. .. .	1	1			6
A399	Clip for ditto .. .. .	2	2			1 0
P287/187	Joint for water inlet pipe .. .. .	1	1			1 3
<b>LUBRICATING SYSTEM</b>						
MG489/12	Oil breather .. .. .	1	1			2 1
MG489/107	Oil base sump .. .. .	1	1			4 17 0
MG489/146	Joint for ditto .. .. .	1	1			3 6
X101/1	Nuts for securing sump .. .. .	14	14	doz.		1 3
X101/2	Spring washer for ditto .. .. .	14	14	doz.		8
X110/3	Set screw for oil base .. .. .	4	4			3
MG348/197	Drain plug for ditto .. .. .	1	1			2 0
X348/16	Fibre washer for ditto .. .. .	1	1	doz.		9
MG489/35	Dipstick (with knob) .. .. .	1	1			1 10
MG489/108	Dipstick adaptor .. .. .	1	1			3 0
X489/8	Joint for ditto .. .. .	1	1	doz.		6
X110/6	Stud for securing ditto .. .. .	2	2			3
X101/1	Nut for ditto .. .. .	2	2	doz.		1 3
X101/2	Spring washer for ditto .. .. .	2	2	doz.		8
MG489/14	Oil strainer assembly .. .. .	1	1			10 10
P287/159	Fibre washer for oil strainer .. .. .	1	1	doz.		1 0

Part No.	DESCRIPTION	No. Used		Price Each		
		2-seater	Tourer	£	s.	d.
MG489/15	Oil suction pipe (sump to pump)	1	1	3	10	
X348/33	Washer for union	1	1	doz.	8	
MG348/213	Union for pump	1	1	1	3	
MG489/16	Oil pump assembly	1	1	1	9	6
MG489/110	Oil pump body	1	1	13	4	
MG489/152	Joint for ditto	1	1	doz.	8	
MG489/111	Oil pump cover	1	1	5	10	
MG489/153	Joint for ditto	1	1	doz.	8	
MG348/164	Plug for oil pump cover	1	1		4	
MG348/162	Combined spindle and gear for oil pump	1	1	6	8	
MG348/160	Oil pump driven gear	1	1	10	10	
MG489/154	Spindle for ditto	1	1		5	
P239/109	Relief valve for oil pump	1	1		7	
MG348/165	Cap nut for relief valve	1	1	2	3	
X363/16	Washer for ditto	1	1	doz.	1	4
P110/158	Spring for ditto	1	1		4	
X420/1	Set screw for securing oil pump (1 $\frac{3}{8}$ " long)	2	2		7	
X420/2	" " " " " " (2 $\frac{3}{8}$ " long)	2	2		9	
X420/3	" " " " " " (2 $\frac{1}{2}$ " long)	1	1		9	
X101/2	Spring washers for ditto	5	5	doz.	8	
MG489/17	Main oil feed pipe (pump to filter)	1	1	2	1	
X348/32	Union for ditto	2	2		6	
X348/37	Washer for ditto	1	1		2	
X489/19	Washer for oil feed (on pump) (copper)	1	1	doz.	5	
MG489/18	Oil filter assembly	1	1	1	16	9
MG489/19	Oil filter case studded	1	1	14	6	
X348/34	Studs for securing oil filter cap	4	4	doz.	1	0
MG468/123	Joint for oil filter cap	1	1		9	
MG468/122	Cap for oil filter	1	1		4	8
X105/3	Nut for securing ditto	4	4	doz.	1	3
X105/4	Spring washers for ditto	4	4	doz.	8	
A522	Tecalemit oil cleaner element	1	1		8	9
X348/36	Spring for element location	1	1	doz.	1	2
MG348/221	Socket for element	1	1		9	
MG348/219	Oil relief valve body	1	1	3	6	
MG348/301	Ball for ditto	1	1	doz.	1	3
X348/35	Spring for ditto	1	1	doz.	1	0
MG348/220	Plug for ditto	1	1		3	
MG348/222	Plate for ditto	1	1	doz.	2	3
P110/106	Oil gauge tap	1	1	2	3	
X348/39	Washer for ditto	1	1		1	
MG489/156	Joint for oil filter case	1	1	doz.	8	
X105/3	Nut for securing oil filter	6	6	doz.	1	3
X105/4	Spring washer for ditto	6	6	doz.	8	
MG489/20	Front bearing and cylinder head oil feed pipe	1	1	4	5	
MG489/160	Joint for feed pipe flange	1	1		2	
X110/39	Set screw for securing flange	1	1		3	
X110/40	Fibre washer for ditto	1	1	doz.	4	
X362/3	Spring washer for ditto	1	1	doz.	2	
X348/29	Union for oil filter	1	1		4	
X348/37	Copper washer for ditto	1	1	doz.	1	0
X348/29	Union for front bearing oil feed pipe	1	1		4	
X348/15	Copper washer for ditto	1	1	doz.	1	0
P287/144	Restrictor pin for cylinder head oil feed pipe	1	1		1	0
MG489/21	Main oil feed pipe (bearings)	1	1	3	10	
MG489/161	Joint for ditto	3	3		2	
X105/14	Set screw for ditto	6	6		3	
X101/2	Spring washer for ditto	6	6	doz.	8	
MG489/22	Cylinder head oil drain pipe (front)	1	1	5	10	
X489/10	Joint for ditto (top)	1	1		2	
X489/11	" " " (bottom)	1	1		2	
X468/11	Bolt for flange	2	2		3	
X101/1	Nut for ditto	2	2	doz.	1	3
X101/2	Washer for ditto	2	2	doz.	8	
X105/14	Set screw for cylinder head oil drain pipe (front)	2	2		2	
X101/2	Spring washer for ditto	2	2	doz.	8	
MG489/23	Cylinder head oil drain pipe (rear)	1	1	4	7	
X489/12	Joint for ditto (bottom)	1	1		2	
X489/13	" " " (top)	1	1	doz.	1	0
X489/21	Set screw for ditto	1	1		2	
X239/4	Washer for ditto	1	1	doz.	6	
X101/1	Nuts for securing studs	2	2	doz.	1	3
X101/2	Washer for ditto	2	2	doz.	8	
MG489/24	Cylinder head oil drain pipe (centre)	1	1	3	10	
X101/1	Nuts for securing studs	2	2	doz.	1	3
X101/2	Washer for ditto	2	2	doz.	8	
X489/13	Joint for ditto (top)	1	1	doz.	1	0
X489/12	" " " (bottom)	1	1		2	
X489/21	Set screw for ditto	1	1		2	
X239/4	Washer for ditto	1	1	doz.	6	

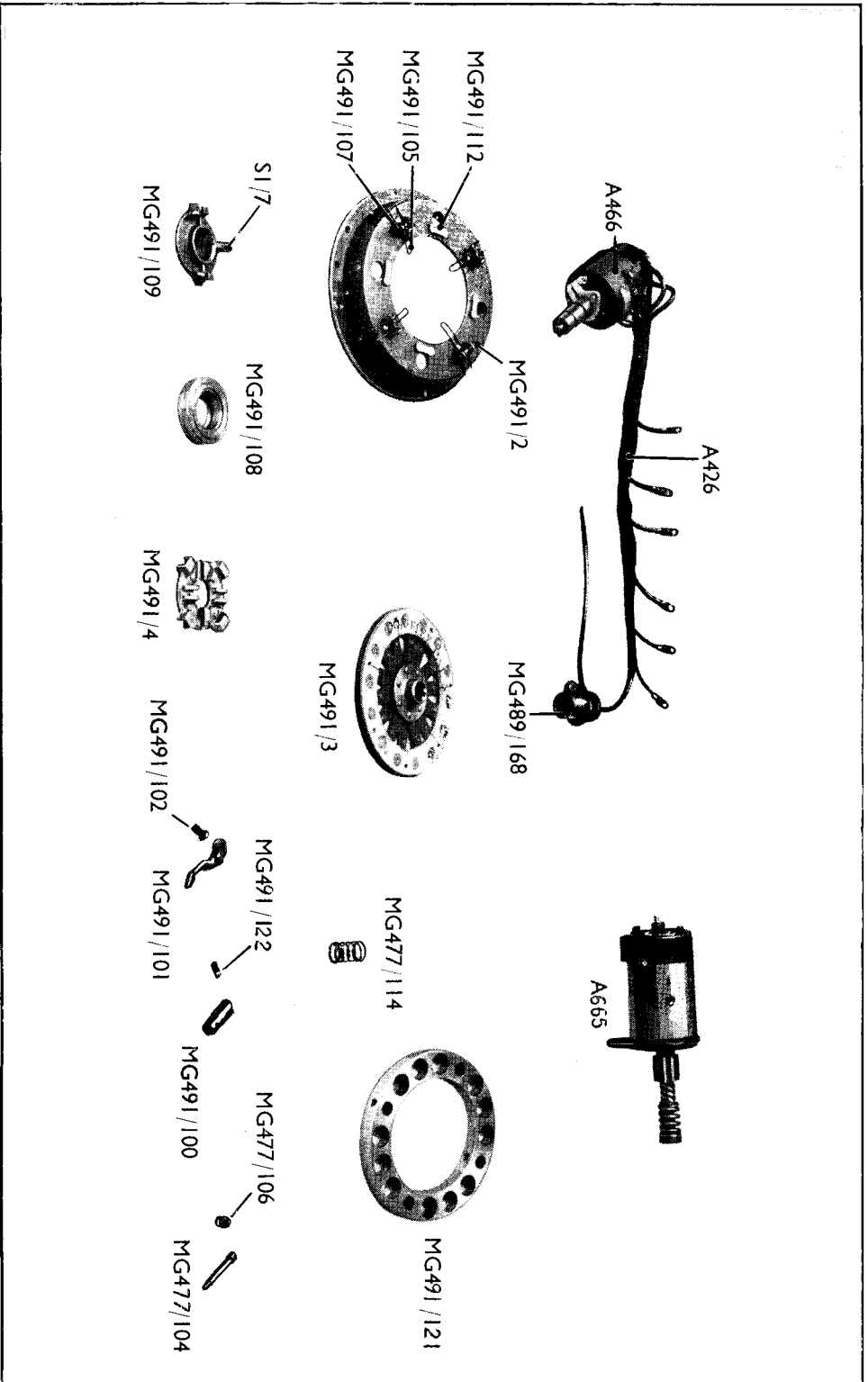



Part No.	DESCRIPTION	No. Used		Price Each		
		2-seater	Tourer	£	s.	d.
<b>ELECTRICAL DETAILS</b>						
A665	Starter (4-brush) complete .. .. .	1	1	4	5	0
X489/20	Set screw for securing ditto .. .. .	1	1			3
X110/12	Bolt for ditto .. .. .	2	2			3
X101/10	Nut for ditto .. .. .	2	2	doz.	1	3
X101/11	Spring washer for ditto .. .. .	3	3	doz.		8
A466	Distributor .. .. .	1	1	2	17	6
X287/13	Set screw for securing ditto .. .. .	1	1			2
X101/2	Spring washer for ditto .. .. .	1	1	doz.		8
MG489/168	Distributor adapter .. .. .	1	1		6	1
MG489/169	Drive gear for oil pump and distributor ..	1	1		9	4
X110/3	Set screw for securing distributor adapter ..	1	1			3
X101/2	Spring washer for ditto .. .. .	1	1	doz.		8
<b>CLUTCH DETAILS</b>						
MG491/2	Clutch cover complete .. .. .	1	1		19	6
MG491/112	Fulcrum pad for clutch cover .. .. .	4	4			4
MG491/113	Rivets for ditto .. .. .	8	8	doz.		6
MG491/107	Fulcrum bracket for operating disc spring ..	4	4			8
MG491/113	Rivets for ditto .. .. .	8	8	doz.		6
MG477/114	Clutch springs .. .. .	12	12			4
MG491/121	Clutch pressure plate .. .. .	1	1		18	9
MG477/104	Clutch driving bolt .. .. .	4	4		1	1
MG477/105	Nut for ditto .. .. .	4	4			2
MG477/106	Spring for ditto .. .. .	4	4			2
MG491/100	Clutch operating pin .. .. .	4	4		1	3
MG491/101	Lever (clutch withdrawal) .. .. .	4	4		4	3
MG491/122	Fulcrum pin for ditto .. .. .	4	4			8
MG491/120	Washer for ditto .. .. .	8	8			1
MG491/102	Adjusting screw for lever .. .. .	4	4			6
MG491/118	Nut for ditto .. .. .	4	4			1
MG491/3	Clutch plate complete (driven) .. .. .	1	1	1	6	6
MG491/4	Clutch operating disc ring complete .. .. .	1	1		6	1
MG491/104	Lining for clutch operating disc ring .. ..	1	1		1	10
X491/1	Rivets for ditto .. .. .	4	4	doz.		6
MG491/105	Retaining spring for clutch operating disc ring ..	4	4			2
MG491/106	Fulcrum pin for ditto .. .. .	4	4		1	2
MG491/108	Withdrawal race .. .. .	1	1		14	3
MG491/109	Sleeve for ditto .. .. .	1	1		5	4
S1/7	Greaser for ditto .. .. .	1	1			3
MG491/110	Pedal (clutch operating) .. .. .	1	1		5	10
P110/422	Cotter pin for ditto .. .. .	1	1			5
1034	Clutch operating shaft .. .. .	1	1		10	10
X491/2	Bolt for securing clutch .. .. .	8	8			6
X110/41	Nut for ditto .. .. .	8	8			3
2569	Clutch pedal stop stud .. .. .	1	1			3
1287	Adjustable stop for ditto .. .. .	1	1			8
1144	Spring (clutch pedal return) .. .. .	1	1			5
1248	Anchor bracket for ditto .. .. .	1	1			4
<b>GEARBOX AND DETAILS WITH REMOTE CONTROL</b>						
MG489/25	Gearbox assembly complete, less clutch pedal, withdrawal and inspection cover .. .. .	1	1	21	0	0
MG489/26	Clutch housing studded .. .. .	1	1	2	1	6
X363/22	Stud for gearbox casing (1 $\frac{1}{4}$ " long) .. ..	6	6	doz.	1	6
MG489/200	Dowels for ditto .. .. .	2	2			2
P110/348	Bush for clutch withdrawal shaft O/S .. ..	1	1		3	5
P110/349	" " " " " " N/S .. .. .	1	1		1	6
X110/70	Disc for ditto .. .. .	1	1	doz.		8
X110/71	Set screw for bushes .. .. .	2	2			3
X101/2	Washer for ditto .. .. .	2	2	doz.		8
MG489/27	Engine bearer tube assembly (rear) .. .. .	1	1	1	0	6
MG489/170	Engine bearer tube (bare) .. .. .	1	1		8	0
MG489/195	Collar for ditto .. .. .	2	2		1	4
MG489/196	Rubber bush for ditto .. .. .	2	2		5	10
2332	Clutch inspection cover .. .. .	1	1		1	4
X110/9	Bolts (clutch pit to bell housing) (1 $\frac{3}{16}$ " long) ..	6	6			4
X110/11	" " " " " " (7/8" long) .. .. .	2	2			3
X105/3	Nuts for ditto .. .. .	6	6	doz.	1	3
X105/4	Spring washers for ditto .. .. .	8	8	doz.		8



Part No.	DESCRIPTION	No. Used		Price Each		
		2-seater	4-seater	£	s.	d.
MG489/28	Gearbox case studded .. .. .	1	1	1	3	0
X363/12	Stud for top cover .. .. .	4	4			2
X363/19	Stud for rear end cover (2 $\frac{3}{4}$ " long) .. .. .	1	1			3
X363/20	" " " " " (1 $\frac{5}{8}$ " long) .. .. .	5	5			3
X363/21	" " " " " (1 $\frac{3}{8}$ " long) .. .. .	1	1			3
MG489/200	Dowel for ditto .. .. .	2	2			2
P110/109	Filler plug and drain .. .. .	2	2		1	6
X110/64	Fibre washer for ditto .. .. .	2	2	doz.		3
X105/3	Nut for securing to clutch housing .. .. .	6	6	doz.	1	3
X105/4	Spring washer for ditto .. .. .	6	6	doz.		8
MG489/172	First motion shaft .. .. .	1	1	1	7	8
P110/366	Oil thrower for ditto (rear) .. .. .	1	1			4
X110/85	Ball race for ditto .. .. .	1	1	8		9
P110/365	Oil thrower for ditto (front) .. .. .	1	1			4
MG363/137	Locking nut for ditto (combined oil return) .. .. .	1	1	3		2
X110/74	Circlip for ditto .. .. .	1	1			3
MG363/165	Retaining plate (for cover securing bolts) .. .. .	1	1			5
X363/27	Bolts for cover .. .. .	4	4			3
X101/1	Nuts for ditto .. .. .	4	4	doz.	1	3
X101/2	Washer for ditto .. .. .	4	4	doz.		8
X110/75	Sealing washer for cover .. .. .	1	1			6
MG363/164	Cover for first motion shaft .. .. .	1	1	3		4
MG363/140	Mainshaft .. .. .	1	1	13		4
X363/23	Roller bearing spigot .. .. .	1	1	4		9
MG363/138	Distance washer for ditto .. .. .	1	1	1		3
MG489/173	Third and top speed sliding gear .. .. .	1	1	15		3
MG489/29	First and second speed sliding gear assembly .. .. .	1	1	1	9	6
MG489/176	Bolt for ditto .. .. .	4	4			5
X105/3	Nut for ditto .. .. .	4	4	doz.	1	3
X110/86	Ball race mainshaft (rear) .. .. .	1	1	11		6
MG363/179	Retaining plate for ditto .. .. .	1	1			6
X112/1	Bolts for ditto .. .. .	2	2			3
X105/3	Nuts for ditto .. .. .	2	2	doz.	1	3
X105/7	Set screw for ditto .. .. .	1	1			3
X105/4	Washer for ditto .. .. .	3	3	doz.		8
MG489/177	Gear, driving (speedometer) .. .. .	1	1	3	10	
MG489/178	Gear, driven (speedometer) .. .. .	1	1	4	5	
P110/389	Thrust button for ditto .. .. .	1	1			0
P110/409	Bearing for ditto .. .. .	1	1	8		9
X110/80	Joint for ditto .. .. .	1	1			4
MG363/177	Rear cover .. .. .	1	1	18		4
X105/3	Nuts (securing) for ditto .. .. .	7	7	doz.	1	3
X105/4	Washer for ditto .. .. .	7	7	doz.		8
MG363/139	Propeller shaft flange .. .. .	1	1	9		4
X105/12	Nuts for ditto .. .. .	1	1			3
X105/13	Washer for ditto .. .. .	1	1			3
MG363/141	Layshaft .. .. .	1	1	5		0
X363/23	Roller bearing .. .. .	2	2	4		9
MG363/138	Distance washer for ditto .. .. .	4	4	1		3
MG489/179	Constant mesh gear .. .. .	1	1	14		3
MG363/152	Spring retaining ring for ditto .. .. .	2	2	doz.	1	8
MG489/180	Third speed constant mesh gear .. .. .	1	1	17		6
MG363/148	Rollers for ditto .. .. .	23	23			2
MG363/149	Washers for ditto .. .. .	2	2			3
MG363/150	Spring retaining ring for ditto .. .. .	1	1	doz.	1	4
MG489/181	First and second layshaft gears .. .. .	1	1	1	8	2
P110/362	Locking screw for layshaft .. .. .	1	1			2
X101/2	Washer for ditto .. .. .	1	1	doz.		8
X489/17	Oil retaining washer for ditto .. .. .	1	1			2
MG489/197	Washer for ditto .. .. .	1	1			2
X489/18	Set screw for securing ditto .. .. .	1	1	doz.	1	0
MG489/198	Tab washer for ditto .. .. .	1	1	doz.	1	0
MG489/203	Reverse shaft .. .. .	1	1	2		9
MG363/24	Reverse gear sliding (bushed) .. .. .	1	1	12		10
MG363/154	Bush for ditto .. .. .	1	1	2		3
X101/10	Nut for reverse shaft .. .. .	1	1	doz.	1	3
X363/24	Washer for ditto .. .. .	1	1	doz.		8
MG489/188	Selector shaft first and second .. .. .	1	1	3		7
MG489/189	Selector fork first and second .. .. .	1	1	5		0

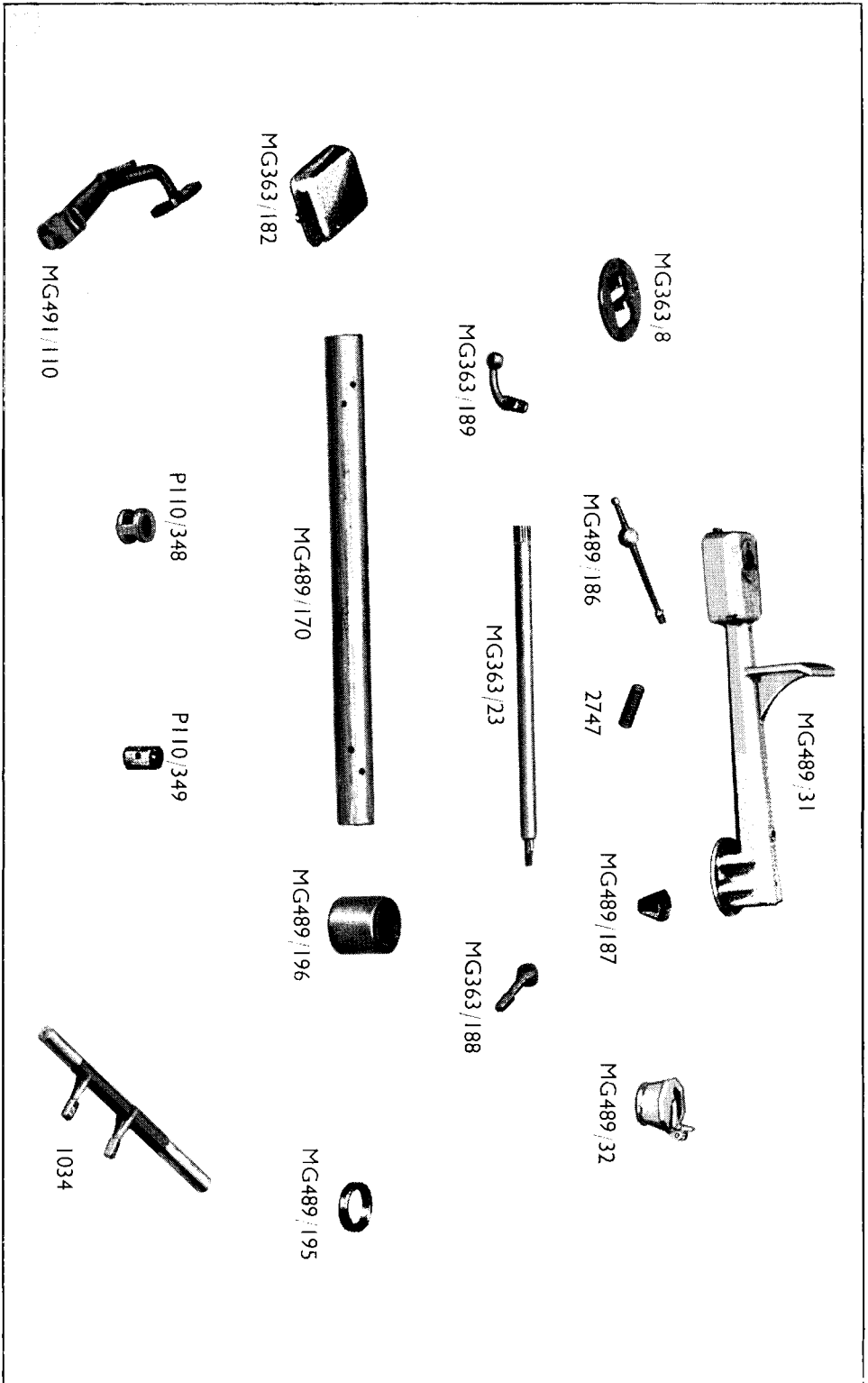

Be sure and quote Chassis Number and Engine Number when ordering Parts.

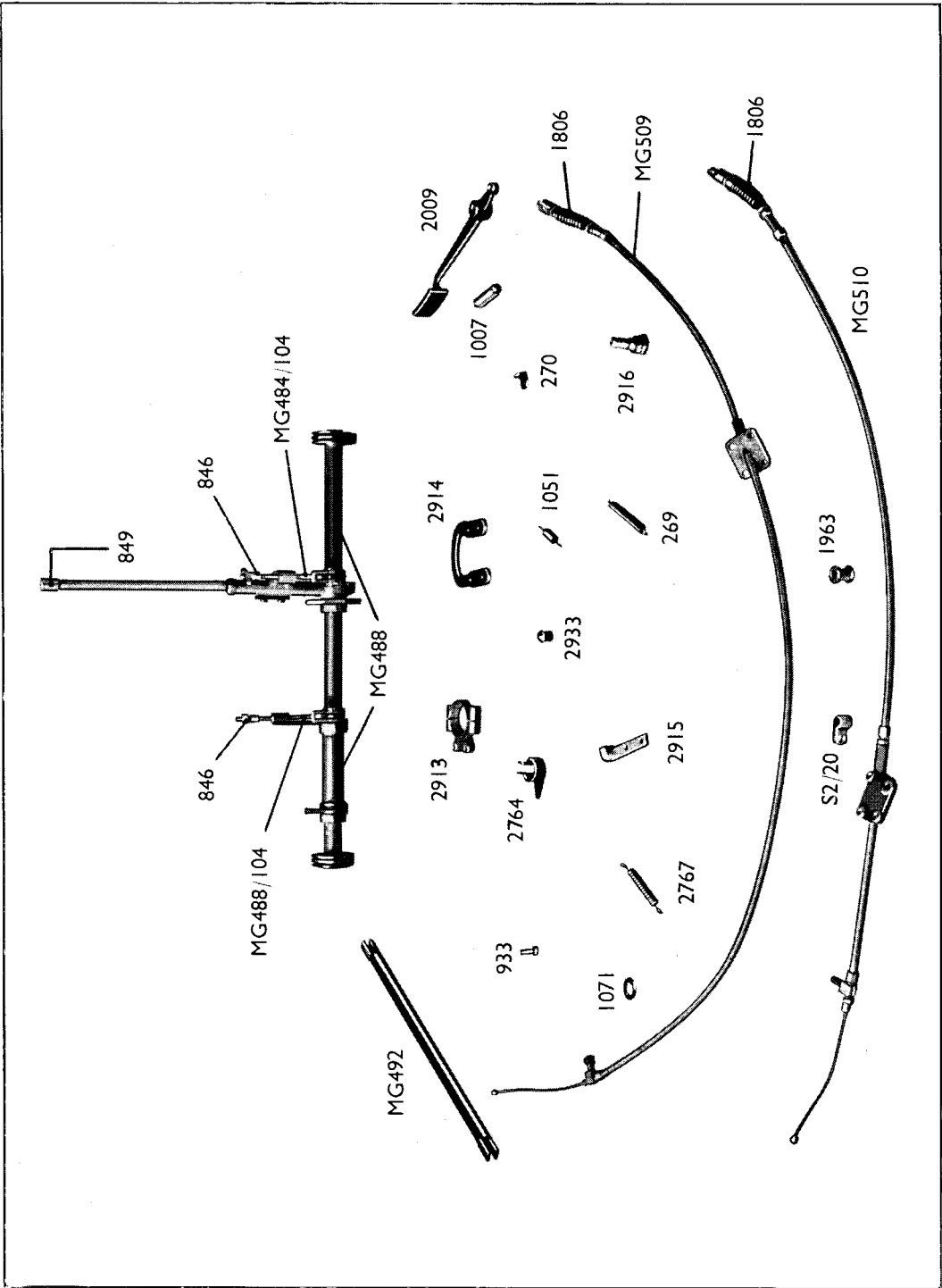

Be sure and specify genuine M.G. Parts.

Part No.	DESCRIPTION	No. Used		Price Each		
		2-seater	Tourer	£	s.	d.
MG412/120	Selector shaft distance piece for ditto (rear)	1	1			4
MG489/190	" " " " (front)	1	1			8
MG489/191	Selector shaft (third and fourth)	1	1	3	2	
MG489/192	Selector fork (third and fourth)	1	1	3	2	
X110/84	Balls for selector fork	2	2	doz.	1	6
X363/28	Spring for ditto	2	2			3
MG363/155	Selecting lever (reverse)	1	1		5	8
MG363/156	Selecting lever fulcrum pin for ditto	1	1			8
X101/10	Nut for ditto	1	1	doz.	1	3
X101/11	Washer for ditto	1	1	doz.		8
MG363/160	Socket reverse locking plunger	1	1		2	0
X363/25	Nut for ditto	1	1			2
X363/26	Washer for ditto	1	1	doz.		8
MG363/161	Plug for socket	1	1			3
MG363/162	Plunger (reverse locking)	1	1			10
MG363/163	Spring for ditto	1	1			11
MG363/159	Selector shaft reverse	1	1		1	6
MG363/157	Selector fork reverse	1	1		1	8
MG363/158	Distance piece for ditto	1	1			3
MG363/178	Selector shaft locking screw	1	1			3
MG363/8	Interlock assembly (change speed)	1	1		3	0
<b>GEAR LEVER REMOTE CONTROL DETAILS</b>						
MG489/30	Remote control assembly (gearbox)	1	1	2	10	0
MG489/31	Housing (gear change) assembly	1	1	1	3	6
X110/38	Disc for ditto	2	2			4
P110/404	Locating peg for lever	1	1	doz.		2
MG489/32	Gate assembly for change speed	1	1		6	1
MG489/184	Stop (reverse)	1	1		1	6
X412/4	Hinge for ditto	1	1			2
X489/15	Washer for ditto	1	1	doz.		3
MG489/185	Spring for stop	1	1			3
X489/16	Screw for ditto	1	1	doz.		6
MG363/198	Shims for change speed gate	As required		doz.	1	2
X110/39	Bolts for fixing gate	3	3			3
X101/2	Washer for ditto	3	3	doz.		8
MG489/186	Lever (change speed)	1	1		7	2
MG489/187	Knob for ditto	1	1		1	5
X363/30	Lock nut for ditto	1	1			2
2747	Spring (anti-rattle) for lever	1	1			5
MG363/189	Lever (shaft actuating)	1	1		4	6
X363/34	Set screw for ditto	1	1			3
X101/2	Washer for ditto	1	1	doz.		8
MG363/23	Shaft (change speed)	1	1		7	6
MG363/188	Lever selector	1	1		5	4
X101/4	Key for ditto	1	1			3
X363/31	Nut for selector lever	1	1			3
X363/32	Washer for ditto	1	1	doz.		4
MG363/182	Tray for housing	1	1		1	6
X110/82	Screw for ditto	2	2	doz.		7
X101/1	Nut for securing remote control to gearbox	4	4	doz.	1	3
X101/2	Washer for ditto	4	4	doz.		8
<b>BRAKE GEAR</b>						
2009	Brake pedal	1	1		5	10
1007	Fulcrum pin for ditto	1	1			9
1365	Rollers for ditto	23	23	set	1	9
MG492	Brake push rod	1	1		6	4
933	Clevis pin for ditto	2	2			6
269	Brake pedal return spring	1	1			3
270	Anchor bracket for ditto	1	1			7
MG488	<b>Brake cross shaft assembly</b>	1	1		2	18 0
842	Roller bearing retainer for ditto	1	1			2 6
841	Rollers for ditto	32	32	set		2 6
MG488/104	Hand and foot brake adjusting rod	2	2		4	2
851	Clevis pin for ditto	2	2			4
846	Wing nut for ditto	2	2		2	9
840	Knob for hand brake lever	1	1		1	3
853	Screw for ditto	1	1			4
852	Hand brake pawl spring	1	1			4
MG488/106	Hand brake pawl rod	1	1			8
857	Hand brake lever ratchet pawl	1	1		2	2
855	Hand brake pawl stud	1	1			4
856	Hand brake pawl screw	2	2			8
838	Bush for brake cross shaft	1	1		1	6
2916	Trunnion for ditto	2	2		1	4
1071	Fibre washer for ditto (Type "B")	2	2			4

Part No.	DESCRIPTION	No. Used		Price Each		
		2-seater	Touret	£	s.	d.
2913	Steady bracket for brake cross shaft .. ..	1	1	4	3	
2767	Return spring for brake cross shaft .. ..	1	1	doz.	1	4
2764	Clip for ditto .. ..	1	1			5
270	Anchor bracket for ditto .. ..	1	1			7
2914	Hand brake ratchet .. ..	1	1	7	9	
2915	Hand brake lever stop .. ..	1	1	4	9	
2933	Rubber buffer for ditto .. ..	1	1	doz.	1	8
1051	Hand brake lever return spring .. ..	1	1			3
MG509	<b>Front brake cable assembly</b> .. ..	2	2	1	0	6
MG510	<b>Rear brake cable assembly</b> .. ..	2	2	18	9	
1806	Concertina type rubber tubing for brake cables ..	4	4			9
1963	Rubber ferrule for rear brake cable .. ..	2	2	2	0	
S2/20	Clip for ditto (on springs) .. ..	2	2			3
P109/100	Clevis pin for cables .. ..	4	4			3
<b>CONTROLS</b>						
MG537	<b>Accelerator cross shaft assembly</b> .. ..	1	1	12	10	
1969	Jet control return spring (on cross shaft) ..	1	1			4
1113	Accelerator pedal stop .. ..	1	1			7
265	Accelerator return spring .. ..	1	1			4
1248	Anchor bracket for ditto .. ..	1	1			2
P122	Coupling rod to throttle (ball jointed) ..	1	1	1	6	
2950	Slow running rod .. ..	1	1	1	3	
2952	Knob for ditto .. ..	1	1			6
132	Spring for ditto .. ..	1	1			7
3057	Bracket for slow running rod .. ..	1	1			4
2951	Jet control rod .. ..	1	1	1	3	
2952	Knob for ditto .. ..	1	1			6
1111	Anti-rattle spring for ditto .. ..	1	1	doz.	1	4
3058	Jet control connecting rod .. ..	1	1			6
1111	Anti-rattle spring for ditto .. ..	1	1	doz.	1	4
181	Yoke end for jet control con. rod .. ..	1	1			6
2934	Clevis pin for ditto .. ..	1	1	doz.	1	0
3047	Rubber bush for control rod .. ..	2	2			2
<b>STEERING GEAR</b>						
MG512	<b>Steering gear assembly (less wheel)</b> .. ..	1	1	6	15	0
MG512/1	Inner column with cam and top end assembled ..	1	1	1	16	0
MG512/2	Inner column with top end .. ..	1	1	15	10	
MG443/103	Steering cam .. ..	1	1	18	5	
MG429/124	Rubber ring for inner column .. ..	1	1			3
MG443/100	Steering box .. ..	1	1	14	4	
MG429/105	Ball cup for cam .. ..	2	2	2	7	
MG429/104	Ball cage for ditto (with balls) .. ..	2	2	3	0	
MG429/103	Rocker-shaft .. ..	1	1	13	0	
MG429/102	Peg for ditto .. ..	1	1	4	8	
MG512/100	Oversize peg for ditto .. ..	1	1	7	0	
MG429/106	Side cover for steering box .. ..	1	1	4	0	
MG429/107	Shim for ditto (.0024") .. ..	As required				4
MG429/108	" " (.005") .. ..	As required				4
MG429/109	" " (.010") .. ..	As required				5
MG429/110	Joint for cover .. ..	1	1			2
MG429/111	Bolt for cover .. ..	3	3			3
MG429/112	Steering drop arm .. ..	1	1	10	8	
MG429/113	Felt washer for ditto .. ..	1	1			6
MG429/114	Pinch bolt for ditto .. ..	1	1			3
MG512/3	Outer column with end flange .. ..	1	1	18	5	
MG429/118	Thrust plate for ditto .. ..	1	1			4
MG429/119	Shim for ditto (.0024") .. ..	As required				4
MG429/120	" " (.005") .. ..	As required				4
MG429/121	" " (.010") .. ..	As required				5
MG512/102	Joint for flange .. ..	1	1			2
MG512/103	Bolt for flange .. ..	2	2			3
MG429/127	Retaining ring for steering column top bush ..	1	1			4
MG429/126	Felt bush for steering column (top) .. ..	1	1			10
MG512/104	Key for steering wheel .. ..	1	1			10
A310	Steering wheel (17") .. ..	1	1	2	2	0
1919	Steering column clamp .. ..	1	1	2	2	
1888	Steering column support bracket .. ..	1	1	2	1	
<b>RADIATOR AND CONNECTIONS</b>						
MG513	<b>Radiator complete</b> .. ..	1	1	14	0	0
MG475/1	Radiator case with badge .. ..	1	1	8	2	6
MG444/102	Headlamp bracket lug .. ..	2	2			5
MG444/103	Tie bar for ditto .. ..	1	1			6
MG444/104	Studs for cylinder head to radiator bracket (on radiator) .. ..	6	6			2
P214/109	Radiator stay rod lug .. ..	2	2			8
MG444/106	Bonnet hinge rod bracket (on radiator) ..	1	1			8

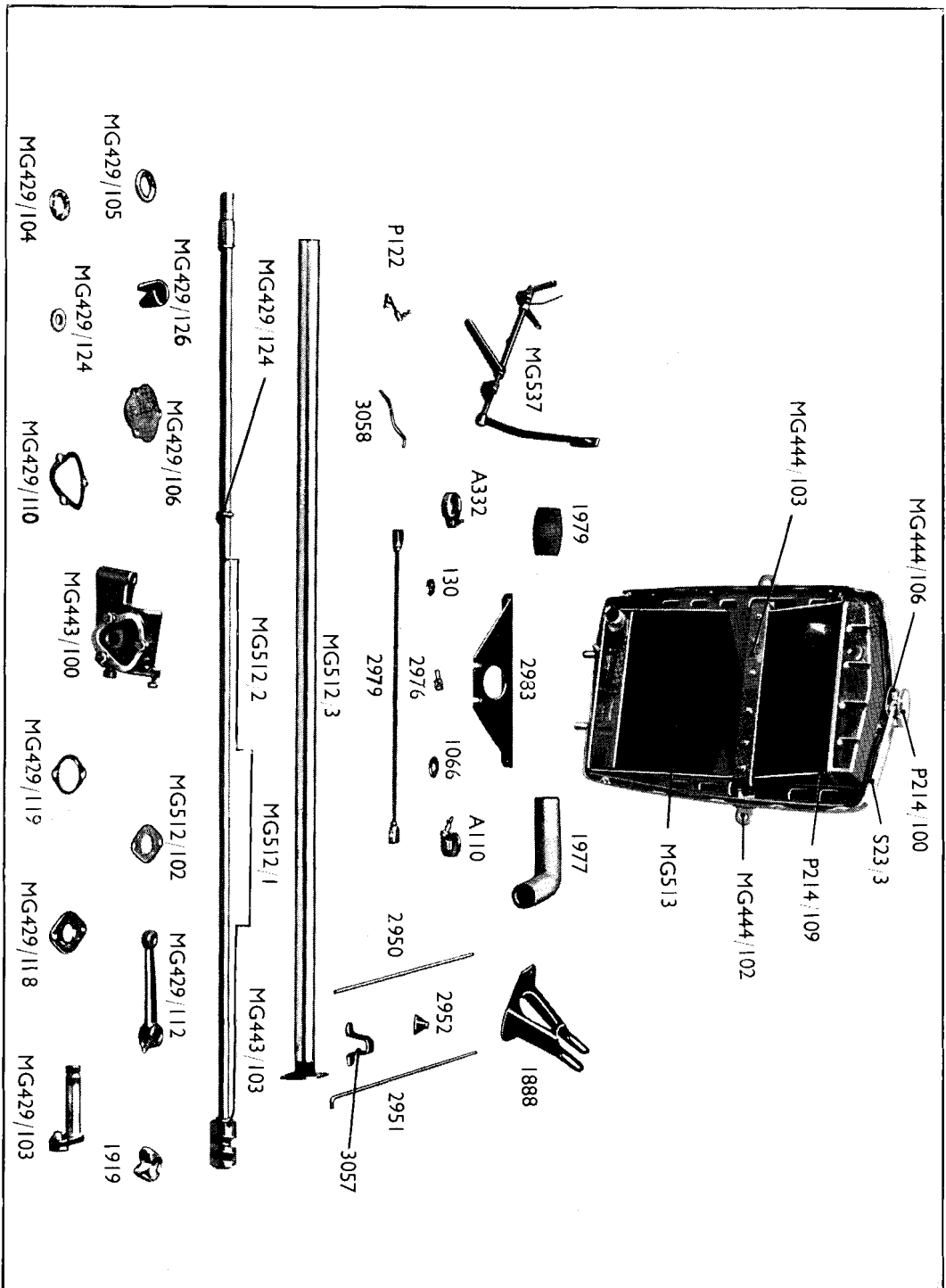

When obtaining Spares be sure they are genuine M.G. Parts.

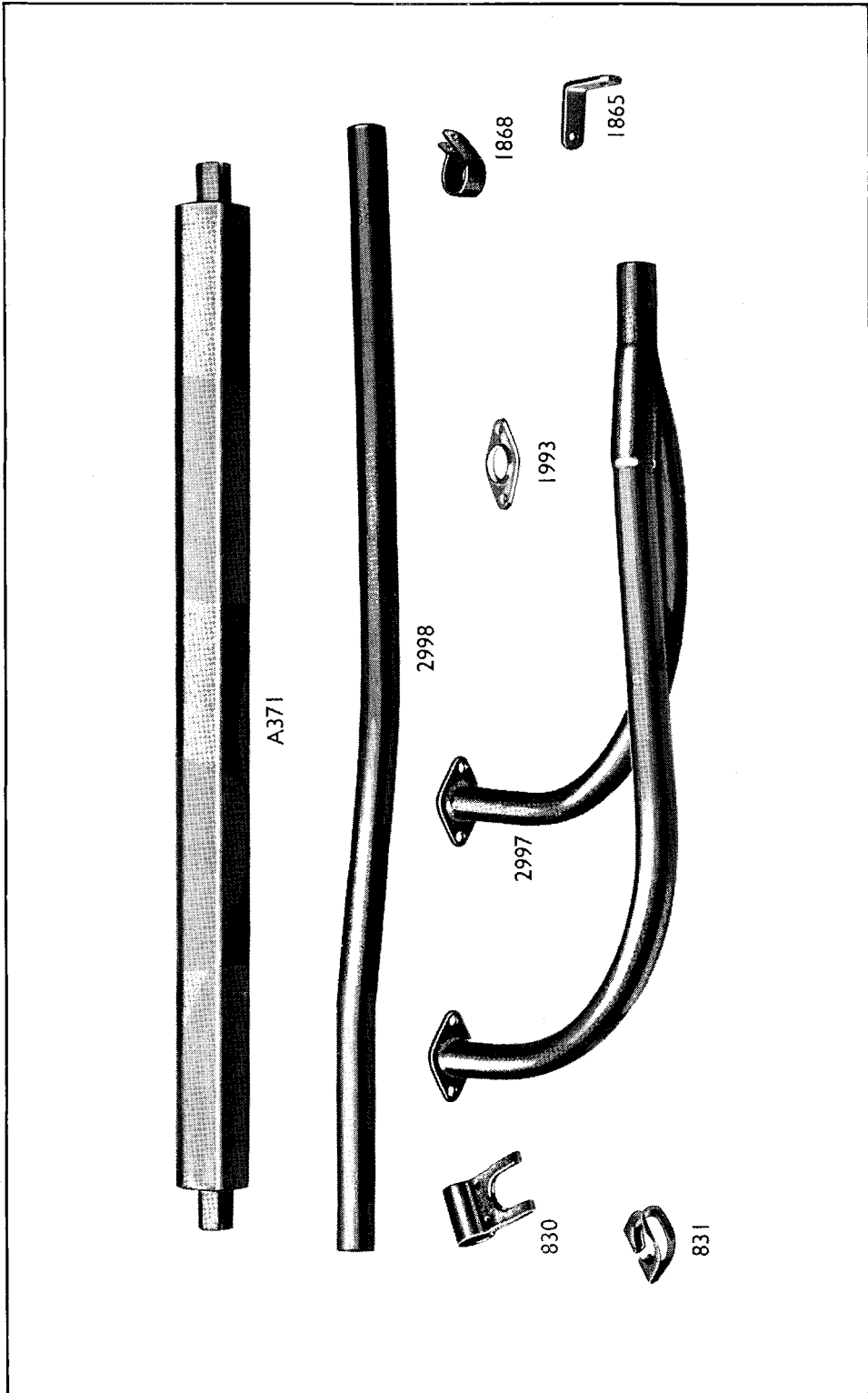

Don't forget to quote the Chassis and Engine Numbers.

Part No.	DESCRIPTION	No. Used		Price Each		
		2-seater	Tourer	£	s.	d.
P214/105	M.G. medallion .. .. .	1	1	5	0	
P214/100	Radiator cap .. .. .	1	1	12	0	
P214/101	Rubber ring for ditto .. .. .	1	1		7	
A153/100	Radiator thermo union .. .. .	1	1	1	0	
MG414/104	Cap for ditto .. .. .	1	1		4	
P282/100	Radiator drain tap .. .. .	1	1	1	9	
P214/103	Fibre washers for ditto and thermo union .. .. .	2	2		2	
S23/3	Bonnet rest tape (6' long) .. .. .	1	1	1	2	
1066	Radiator mounting washers (fibre) .. .. .	3	3		3	
130	" " (steel) .. .. .	2	2	doz.	1	6
2626	Rubber moulding for headlamp bracket lugs .. .. .	2	2		4	
2983	Cylinder head to radiator bracket .. .. .	1	1	3	4	
1977	Water hose connection (top) .. .. .	1	1	1	11	
A332	Clip for ditto .. .. .	2	2		9	
1979	Water hose connection (bottom) .. .. .	1	1	1	6	
A110	Clip for ditto .. .. .	2	2		10	
1843	Rubber tube (for radiator overflow) (3" long) .. .. .	1	1		2	
2979	Radiator stay rod .. .. .	2	2		5	
1069	Fork end for ditto .. .. .	4	4		6	
2976	Radiator stay rod eye bolt (on dash panel) .. .. .	2	2		5	
<b>EXHAUST SYSTEM AND SILENCER</b>						
2997	Front exhaust pipe .. .. .	1	1	15	9	
1993	Gasket for ditto .. .. .	2	2		5	
A371	Silencer .. .. .	1	1	1	3	0
1868	Silencer clip .. .. .	2	2		6	
1865	Bracket for silencer clip .. .. .	2	2		8	
831	Fume excluder clip .. .. .	2	2		8	
2998	Exhaust pipe (rear) .. .. .	1	1	7	2	
830	Clip for ditto .. .. .	1	1	1	10	
<b>PETROL TANK AND PIPES (Illustration, Page 31)</b>						
MG499	<b>Petrol tank (unpainted) (less cap)</b> .. .. .	1	1	1	13	2
MG499/101	Main petrol pipe attachment .. .. .	1	1		10	
MG438/102	Reserve petrol pipe attachment with gauze .. .. .	1	1	2	9	
S3/16	$\frac{3}{8}$ " gas to $\frac{1}{4}$ " gas cone union adaptor .. .. .	2	2		6	
P352/100	Drain plug .. .. .	1	1	1	0	
P214/103	Fibre washer for unions and drain plug .. .. .	3	3		2	
3017	Washer for petrol gauge .. .. .	1	1		4	
S26/1	Hose for neck .. .. .	1	1		11	
3048	Neck for tank .. .. .	1	1	8	3	
A611	Clip for ditto .. .. .	2	2	2	0	
3049	Rubber moulding for tank neck .. .. .	1	1	1	5	
1464	Petrol tank cap .. .. .	1	1	4	2	
3061	Support channel for tank .. .. .	2	2	9	10	
2965	Petrol tank straps .. .. .	2	2	1	2	
1904	Rubber packing for tank straps (26" long) .. .. .	2	2		10	
3007	Rubber packing for tank seating .. .. .	2	2	1	3	
2975	Main petrol pipe .. .. .	2	2	3	10	
S3/2	$\frac{1}{4}$ " gas cone to $\frac{1}{4}$ " gas cone union adaptor .. .. .	2	2		6	
1859	Petrol pipe with headed unions (main pipe to tap) .. .. .	2	2	2	3	
MG476	<b>Petrol tap with remote control</b> .. .. .	1	1	12	0	
MG476/2	Petrol tap complete (less remote control) .. .. .	1	1	7	8	
MG476/100	Knob for control rod .. .. .	1	1	2	6	
MG476/101	Fixing plate on fascia panel .. .. .	1	1	1	10	
1112	Rubber bush for ditto .. .. .	2	2		3	
MG476/102	Control rod for petrol tap (25" long) .. .. .	1	1		8	
MG476/103	Actuating washer for control rod .. .. .	1	1	1	0	
3063	Bracket for petrol tap remote control (on fascia panel) .. .. .	1	1		11	
2320	Bracket for securing petrol tap .. .. .	1	1		3	
2865	Petrol pipe with headed unions (tap to pump) .. .. .	1	1		0	
A444	Petrol pump (12-volt) .. .. .	1	1	2	10	0
A568	Petrol pipe (flexible) (pump to rear carburetter) .. .. .	1	1	4	2	
A614	Ditto (flexible) (between carburetters) .. .. .	1	1	4	9	
S2/19	Petrol pipe and Teealemit clip .. .. .	4	4		4	
S2/23	Petrol pipe clip (double central fixing) .. .. .	1	1		7	
S2/9	" " " (double end fixing) .. .. .	1	1		4	



Part No.	DESCRIPTION	No. Used		Price Each		
		Greaser	Tourer	£	s.	d.
<b>ACCESSORIES AND SUNDRIES</b>						
A570	Wheels .. .. .	5	5	2	2	0
1123	Hub cap O/S .. .. .	2	2		9	7
1756	" " N/S .. .. .	2	2		9	7
2953	Instruction plate for slow-running and mixture control .. .. .	1	1			6
A289	Licence holder .. .. .	1	1		6	0
2357	Starting handle clip .. .. .	3	3	doz.	2	3
2955	Clips for tyre pump .. .. .	2	2			4
3002	Spare sparking plug carrier .. .. .	1	1		5	0
MG531	<b>Front shock absorbers (complete)</b> .. .. .	1 pr.	1 pr.	pair	6	1 0
A613	Front shock absorber (less mounting pins) .. .. .	2	2		2	15 6
MG531/100	Top mounting pin for ditto .. .. .	2	2			2 6
MG530/101	Bottom mounting pin for ditto .. .. .	2	2			2 6
MG533	<b>Rear shock absorbers (complete)</b> .. .. .	1 pr.	1 pr.	pair	3	15 0
A608	Shock absorber (less arms and links) .. .. .	2	2		1	10 0
MG533/1	Rear shock absorber arm (bushed) with connecting link and mounting pin .. .. .	2	2		12	6
3020	Special nut for shock absorber mounting .. .. .	2	2			3
2977	Rear shock absorber mounting bracket (on frame) .. .. .	2	2		3	4
3059	Rear shock absorber tie bar .. .. .	1	1		3	10
3062	Special bolt for ditto .. .. .	2	2			6
178	Front number-plate .. .. .	1	1		2	4
1124	Rear number-plate .. .. .	1	1		2	4
B255/113	Rear number-plate bar .. .. .	—	—		5	3
MG520/102	Rear number-plate bracket .. .. .	2	—		1	6
MG514	<b>Tecalemit grouped lubricating system</b> .. .. .	1	1	2	3	6
MG514/100	Pipe for ditto (1' 6" long) .. .. .	1	1		1	6
MG514/101	Pipe for ditto (2' 5½" long) .. .. .	2	2		2	1
MG514/102	Pipe for ditto (2' 10" long) .. .. .	2	2		2	6
MG481/100	Pipe for ditto (3' 2" long) .. .. .	2	2		2	6
MG410/100	Pipe for ditto (4' 4" long) .. .. .	2	2		3	7
MG514/103	Pipe for ditto (5' 8" long) .. .. .	2	2		4	3
P359/1	Battery plate fitting (1-way) (on dashboard wall) (65°) .. .. .	4	4		1	6
P359/2	Ditto (2-way) (on dashboard wall) (65°) .. .. .	2	2		1	9
P278/109	Adjustable feed plug (1-way) (⅝" B.S.F.) (steering box, rear spring rear shackles and front spring rear shackle N/S) .. .. .	4	4		1	3
P278/110	Adjustable feed plug (2-way) (⅝" B.S.F.) (front spring rear shackle O/S and brake cross shaft) .. .. .	3	3		1	6
P359/103	Feed plug (1-way) for brake cables .. .. .	4	4		1	0
P113/110	Fibre washer (thick) .. .. .	11	11	doz.	1	0
P113/111	" (thin) .. .. .	34	34	doz.	6	
P113/109	Clip for 1 pipe .. .. .	5	5	doz.	6	
P278/111	Clip for 2 pipes .. .. .	4	4	doz.	1	6
MG369/106	Support for 4 pipes .. .. .	2	2			2
P278/113	Bolt (with nut for clips) .. .. .	9	9	doz.	2	2
S1/5	Greaser nipple for rear hubs and front of gearbox remote control .. .. .	3	3			3
S1/4	Greaser nipple for front spring front shackles, steering knuckles and rear of remote control .. .. .	7	7			8
S1/1	Greaser nipple for draglink and track rod .. .. .	4	4			8
S1/7	Greaser nipple for accelerator cross shaft .. .. .	1	1			3
S1/6	Greaser nipple for propeller shaft .. .. .	2	2			4
1220	Instruction plate for greaser nipple O/S (on dashboard wall) .. .. .	1	1		1	1
1221	Ditto N/S (on dashboard wall) .. .. .	1	1		1	1
<b>DASHBOARD AND FUME EXCLUDERS</b>						
(Illustration, Page 32)						
2967	Dashboard wall O/S .. .. .	1	1		3	4
2968	" " N/S .. .. .	1	1		3	4
2966	Dash panel .. .. .	1	1	1	6	0
2980	Rubber seal (dash panel to body) (7' long) .. .. .	1	1		5	6
2924	Carpet fixing plate .. .. .	1	1		2	0
2926	Clutch housing seal (Sorbo rubber) .. .. .	1	1		2	9
2003	Draught excluder for steering column (rubber) .. .. .	1	1		3	7
2070	Backing plate for ditto .. .. .	1	1			7
2001	Aluminium draught excluder block O/S .. .. .	1	1		1	4
2002	" " " " N/S .. .. .	1	1		1	4
2987	Undertray .. .. .	1	1		15	3

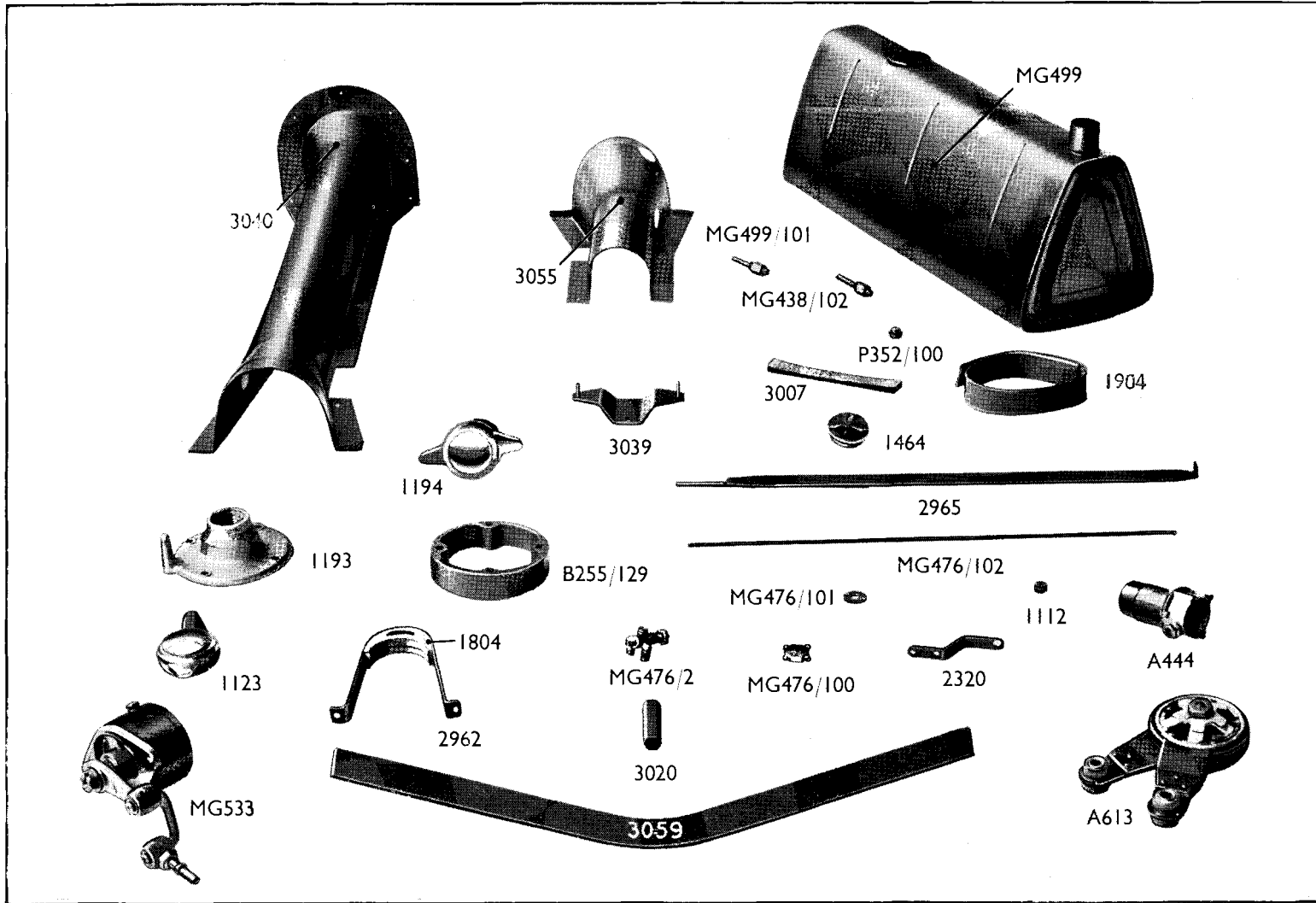

When ordering Parts be sure they are genuine M.G.

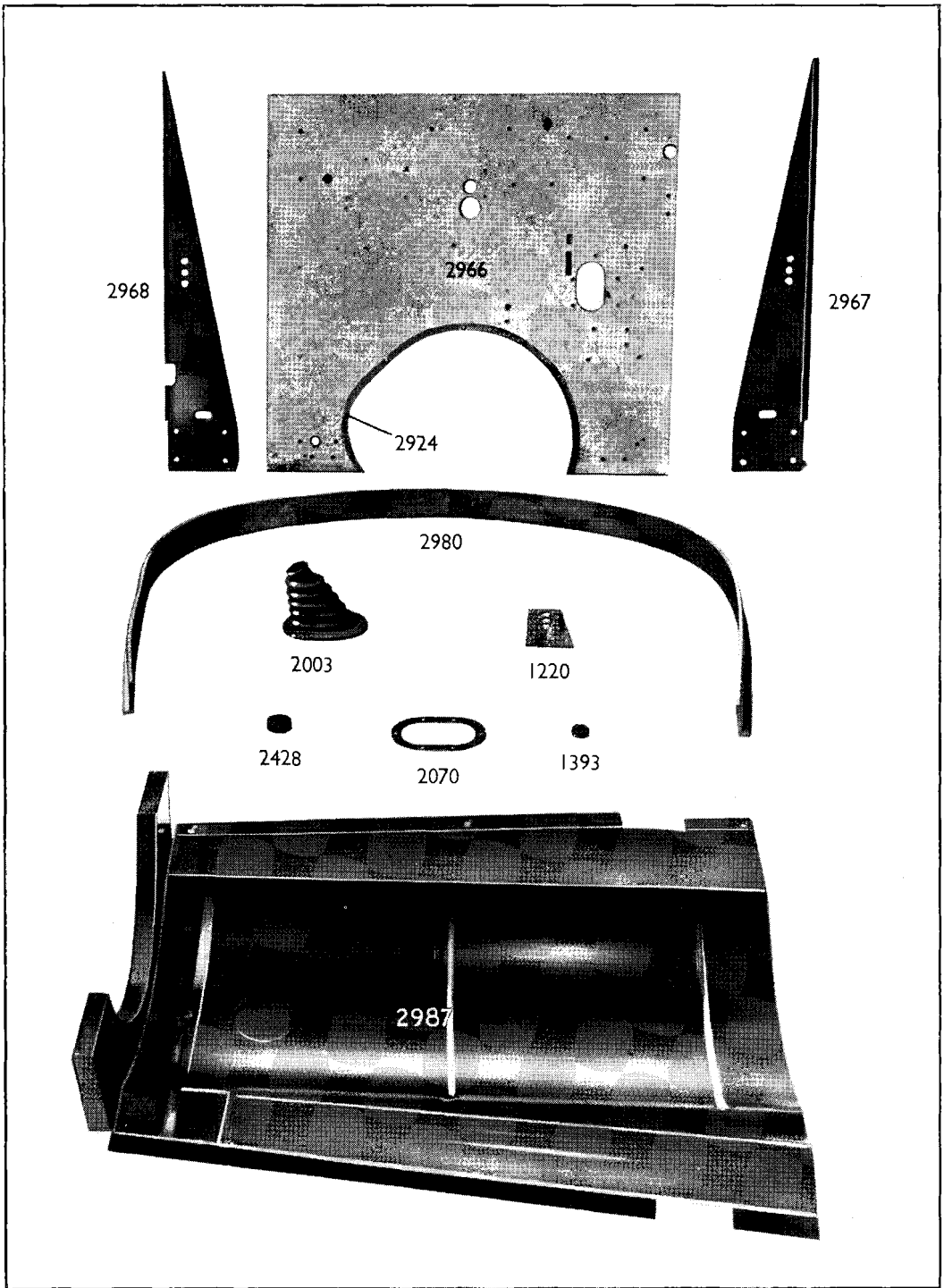

**Be sure and quote Chassis Number and Engine Number when ordering Parts.**

Part No.	DESCRIPTION	No. Used		Price Each		
		2-seater	Tourer	£	s.	d.

### ELECTRICAL EQUIPMENT AND INSTRUMENTS

(Illustration, Page 35)

A560	Instrument panel	1	1	1	10	0
A592	Revolution counter (5" with m.p.h. in top gear)	1	1	6	13	0
2792	Octagonal mask for ditto	1	1	5	6	
A593	Revolution counter cable	1	1	15	0	
2428	Rubber bush for ditto	1	1	4		
A594	Oil gauge	1	1	12	6	
1192	Oil gauge pipe line with unions	1	1	3	6	
3066	Rubber bush for oil gauge pipe (in dash panel)	1	1	5		
335	Fibre washers for ditto	2	2	1		
A595	Mileometer	1	1	2	10	0
A596	Mileometer cable	1	1	15	0	
A597	Mileometer angle drive box	1	1	10	6	
A682	Petrol gauge (electric)	1	1	19	6	
2341	Octagonal mask for ditto	1	1	3	8	
A561	Combined horn and dipper switch mounted on C.P. base (with 4 switches)	1	1	1	18	0
S27/2	Rubber bush (through dash panel) (for horn and dipper switch cable)	1	1	3		
A352	Battery complete with lid and rods	2	2	2	16	6
A247	Starter switch	1	1	7	6	
A547	Cut-out and junction box	1	1	1	8	6
A499	Ignition coil (12-volt)	1	1	1	10	0
A492	Headlamps (12-volt)	1 pr.	1 pr. pair	5	16	0
A548	Sidelamps (12-volt)	1 pr.	1 pr. pair	1	7	6
A405	Stop and tail-lamp (12-volt)	1	1	16	6	
A493	Switch for stop and tail-lamp	1	1	2	6	
S2/35	Clip for ditto (on brake push rod)	1	1	4		
A555	Dashlamp	2	2	5	0	
A556	Direction indicator with cable	2	2	15	6	
A550	Horn with stoneguard	1	1	2	15	0
3054	Special bolt for securing ditto	1	1	6		
A382	Windscreen wiper motor	1	1	2	2	0
A388	Windscreen wiper blade assembly	1	1	14	10	
S27/3	Rubber bush for windscreen wiper cable (in scuttle)	1	1	2		
A389	Driving mirror with bracket	1	1	13	6	
A565	Harnessed cables	1 set	1 set	4	12	6
S2/1	Wiring clip for ditto (single $\frac{5}{8}$ " dia.)	1	1	3		
S2/2	" " " " (single $\frac{3}{8}$ " dia.)	8	8	3		
S2/3	" " " " (single $\frac{1}{2}$ " dia.)	8	10	3		
S2/5	" " " " (single $\frac{11}{16}$ " dia.)	5	5	4		
S2/6	" " " " (single 1" dia.)	3	3	5		
S2/12	Binding clip	22	20	4		
1393	Rubber bush for cables	1	1	4		
2587	Wiring cover (front of dash)	1	1	1	8	
A426	High-tension leads	1 set	1 set	9	6	
A563	Foglamp	1	1	1	13	6
S24/1	Flexible metallic sheathing (8" long) (for ditto)	1	1	1	6	
A607	Oil thermometer with pipe line	1	1	1	5	0
2341	Mask for ditto	1	1	3	8	
S27/1	Rubber bush for stop and tail-lamp cable, horn cable and fog lamp cable	2	3	4		

### BONNET, WINGS AND FAIRINGS

(Illustrations, Pages 36-39)

2960	Front wing O/S (unpainted)	1	1	3	0	6
2961	" " N/S (unpainted)	1	1	3	0	6
2946	Front wing stay and shock absorber bracket O/S	1	1	3	4	
2947	" " " " " N/S	1	1	3	4	
3034	Front wing support stay	2	2	9	8	
S17/4	Silentbloc for ditto	2	2	3	4	
2992	Top bracket for front wing stay	2	2	1	0	
3050	Headlamp bracket O/S	1	1	6	8	
3051	" " " N/S	1	1	6	8	
2585	Rubber packing for ditto	2	2	4		
2586	Rubber moulding for ditto	2	2	6		
2577	Bolt for headlamp bracket	2	2	1	0	
2563	Rubber packing for sidelamps	2	2	3		
2958	Rear wing O/S (unpainted)	1	1	1	16	8
2959	" " N/S (unpainted)	1	1	1	16	8
2904	Running-board O/S (unpainted)	1	1	1	2	3
2905	" " N/S (unpainted)	1	1	1	2	3
2981	Support bracket for ditto O/S	2	2	2	6	
2982	" " " N/S	2	2	2	6	
3071	Rubber moulding between running-board and wing O/S	1	1	1	4	
3072	Ditto N/S	1	1	1	4	

Part No.	DESCRIPTION	No. Used		Price Each		
		2-seater	Tourer	£	s.	d.
2590	Step channelling for running-board (aluminium) (36" long) .. .. .	2	2	4	8	
2590	Ditto (31" long) .. .. .	2	2	4	6	
2590	Ditto (16½" long) .. .. .	2	2	2	3	
2591	Rubber for step channelling (36" long) .. .. .	2	2	2	4	
2591	" " " " (31" long) .. .. .	2	2	2	3	
2591	" " " " (16½" long) .. .. .	2	2	1	1	
3035	Front fairing (unpainted) .. .. .	1	1	17	4	
P214/105	M.G. medallion for ditto .. .. .	1	1	5	0	
S23/1	Rubber insertion for ditto on side members (18" long) .. .. .	2	2	5		
S23/1	Rubber insertion for ditto between radiator and fairing (30" long) .. .. .	1	1	9		
361	Dome nuts (C.P.) for securing ditto .. .. .	4	4	6		
380	Flat washers (C.P.) for ditto .. .. .	4	4	4		
MG518	<b>Bonnet (unpainted)</b> .. .. .	1	1	3	9	0
MG518/100	Bonnet side O/S (unpainted) .. .. .	1	1	1	4	10
MG518/101	" " N/S (unpainted) .. .. .	1	1	1	4	10
MG518/102	Bonnet side hinge rod .. .. .	2	2	1	7	
MG518/103	Bonnet top O/S (unpainted) .. .. .	1	1	11	6	
MG518/104	" " N/S (unpainted) .. .. .	1	1	11	6	
MG518/105	Bonnet top hinge rod .. .. .	1	1	1	7	
MG498/106	Bonnet buttons .. .. .	4	4	4		
MG444/106	Bonnet hinge rod bracket (rear) .. .. .	1	1	8		
MG516	<b>Bonnet fasteners complete O/S and N/S</b> .. .. .	2	2	5	0	
A584	Bonnet fastener complete (less handle) O/S & N/S .. .. .	2	2	2	6	
MG516/100	Bonnet fastener handle O/S & N/S .. .. .	2	2	2	6	
3052	Bracket for horn and foglamp .. .. .	2	2	5	4	
2586	Rubber moulding for ditto .. .. .	2	2	6		
3053	Badge bar (C.P.) .. .. .	1	1	3	8	
B254/174	Bonnet board O/S .. .. .	1	1	18	9	
B254/175	" " N/S .. .. .	1	1	18	9	
2321	Bracket for bonnet board .. .. .	2	2	6		
S23/7	Rubber for rear bonnet rest (82") .. .. .	1	1	3	8	
B254/118	Chromium plated beading round scuttle .. .. .	1	1	1	1	3
<b>PROPELLER SHAFT SHROUD AND FITTINGS</b>						
(Illustration, Page 31)						
3040	Propeller shaft shroud .. .. .	1	—	1	0	6
3039	Platform for ditto (front) .. .. .	1	—	2	1	
S23/1	Rubber for ditto (2" long) .. .. .	2	—	1		
3038	Support bracket for shroud .. .. .	1	—	3	4	
3042	" U " clip for ditto .. .. .	1	—	5		
3041	Platform for propeller shaft shroud (rear) .. .. .	1	—	1	9	
3055	Propeller shaft shroud (front) .. .. .	—	1	11	0	
2321	Floorboard support bracket (front) (on dash panel) .. .. .	2	2	6		
3086	Ditto (rear) .. .. .	—	1	2	9	
<b>SPARE WHEEL CARRIER FITTINGS</b>						
(Illustration, Page 31)						
B254/176	Packing block for spare wheel carrier (on body) .. .. .	1	—	3	8	
B255/129	" " " " (on body) .. .. .	—	1	16	0	
1193	Spare wheel hub (aluminium) .. .. .	1	1	13	0	
3060	Anchor plates with bolts for ditto .. .. .	—	2	2	0	
1194	Spare wheel lock nut and sleeve .. .. .	1	1	14	0	
<b>BODY DETAILS</b>						
(N.a. Two-seater Body). (Illustrations, Pages 39, 40, 41)						
B254	Body complete .. .. .	—	1	Price on application		
<b>DOORS, LOCKS AND HINGES</b>						
B254/1	Door (upholstered) (less fittings) O/S .. .. .	1	—	5	12	6
B254/124	Door hinge (top) O/S .. .. .	1	—	3	8	
B254/126	" " (bottom) O/S .. .. .	1	—	3	8	
B254/182	Door hinge pins .. .. .	2	—	4		
B254/128	Door lock O/S complete .. .. .	1	—	17	6	
B254/179	Door lock striking plate .. .. .	1	—	7	6	
B254/130	Door handle O/S .. .. .	1	—	5	0	
B225/148	Door check strap .. .. .	1	—	2	0	
B235/116	Door rubber buffer, shoe and plate .. .. .	2	—	7		
B254/133	Door rubber buffer on body .. .. .	1	—	6		
B224/137	Sidescreeen securing clamp (on door) .. .. .	2	—	2	5	
B254/2	Door (upholstered) (less fittings) N/S .. .. .	1	—	5	12	6
B254/125	Door hinge (top) N/S .. .. .	1	—	3	8	
B254/127	" " (bottom) N/S .. .. .	1	—	3	8	
B254/182	Door hinge pins .. .. .	2	—	4		

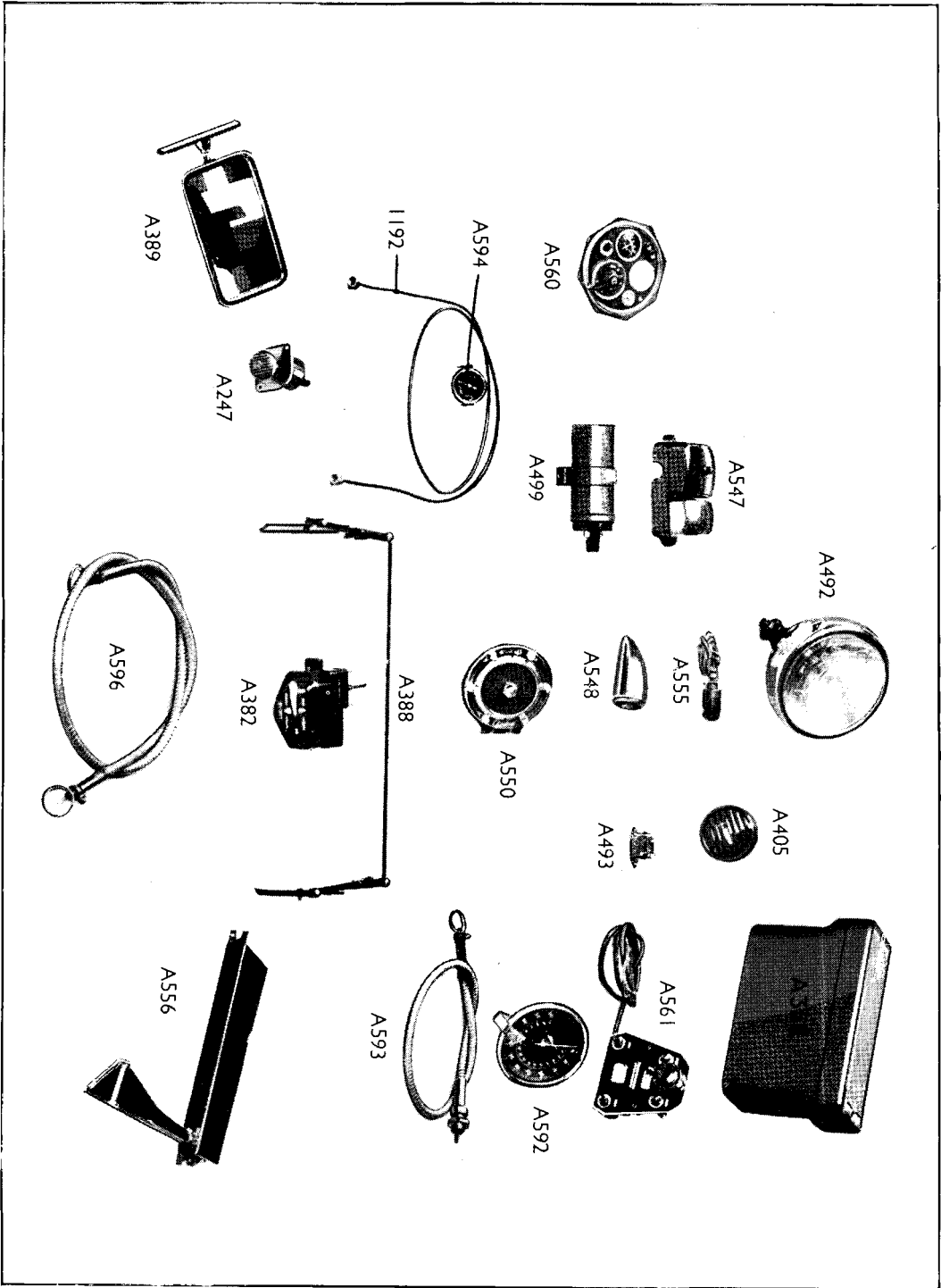

Be sure and specify genuine M.G. Parts.

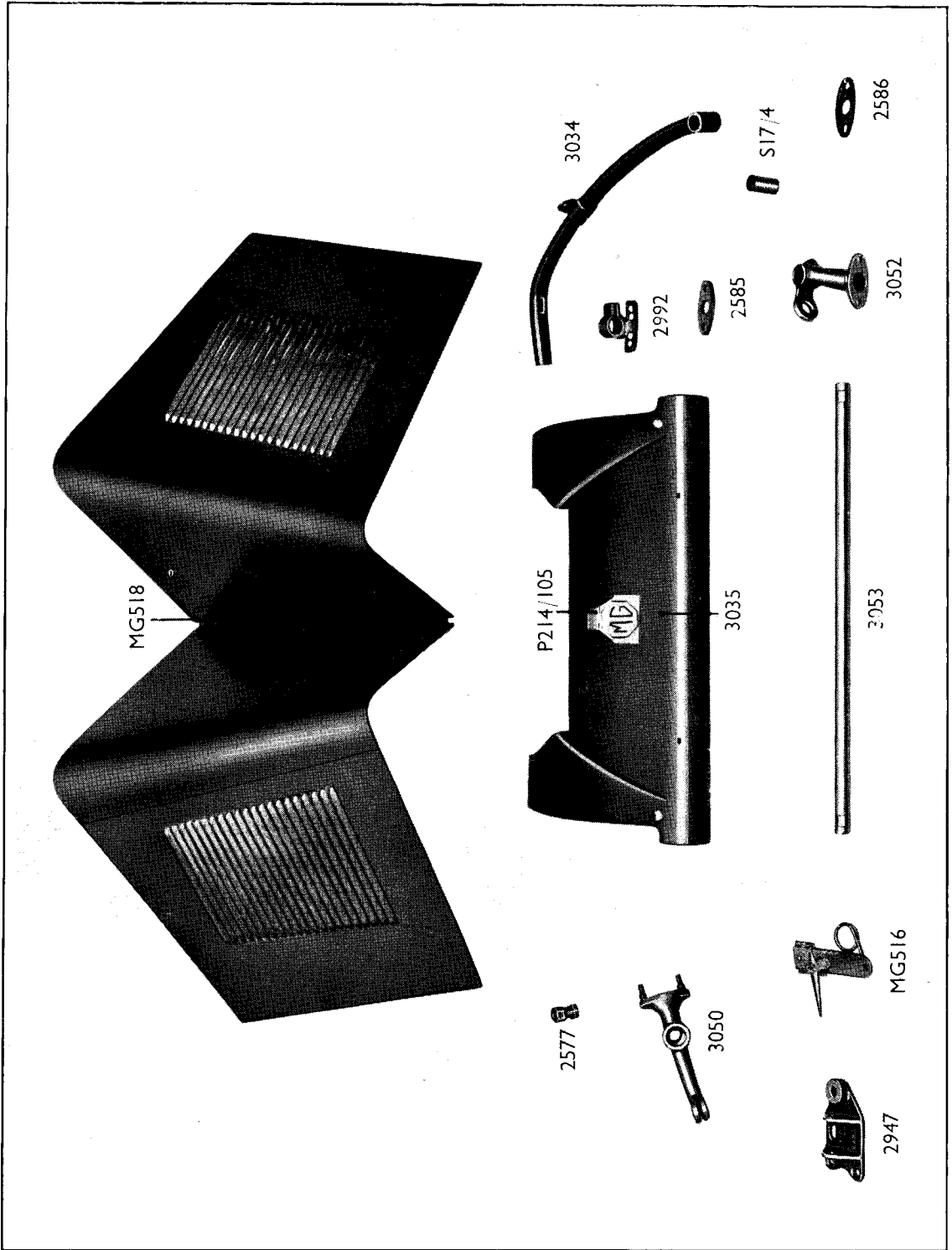

When obtaining Spares be sure they are genuine M.G. Parts.

Part No	DESCRIPTION	No. Used	Price Each		
			£	s.	d.
			2-seater		
B254/129	Door lock N/S complete .. .. .	1	17	6	
B254/179	Door lock striking plate .. .. .	1	7	6	
B254/131	Door handle N/S .. .. .	1	5	0	
B225/148	Door check strap .. .. .	1	2	0	
B235/116	Door rubber buffer, shoe and plate .. .. .	2		7	
B254/133	Door rubber buffer on body .. .. .	1		6	
B224/137	Sidescreeen securing clamp on door .. .. .	2	2	5	
B254/134	Door tread plate O/S .. .. .	1	3	10	
B254/135	" " " N/S .. .. .	1	3	10	
<b>SEATS AND FITTINGS</b>					
B254/136	Seat squab (less tonneau cover) .. .. .	1	6	17	6
B254/138	Tonneau cover .. .. .	1	15	3	
B251/109	Squab adjusting slide with fixing bracket .. .. .	4		1	10
B251/111	Squab adjusting bracket on body and floorboard .. .. .	4		8	
B251/112	Wing nut for ditto .. .. .	4		1	0
B254/139	Seat cushion O/S .. .. .	1	2	9	0
B254/140	" " N/S .. .. .	1	2	9	0
<b>FLOORBOARDS AND CARPETS</b>					
B254/165	Floorboard O/S (front) .. .. .	1	6	1	
B254/166	" N/S (front) .. .. .	1	6	1	
B254/167	" O/S (rear) .. .. .	1	9	0	
B254/168	" N/S (rear) .. .. .	1	9	0	
B254/169	Passenger foot slope .. .. .	1	8	3	
B254/170	Carpet (gearbox) .. .. .	1	2	9	0
B220/109	Rubber mat for carpet .. .. .	2	2	0	
B254/178	Leather cover for propeller shaft shroud .. .. .	1	13	0	
<b>WINDSCREEN AND DETAILS</b>					
B254/4	Windscreen complete .. .. .	1	6	3	0
B254/5	Windscreen frame complete (less glass) .. .. .	1	4	10	0
B254/143	Windscreen frame (barc) .. .. .	1	1	10	0
B254/144	Windscreen side support (bottom) O/S .. .. .	1	18	6	
B254/145	" " " (bottom) N/S .. .. .	1	18	6	
B254/146	" " " (top) .. .. .	2	4	6	
B254/148	Windscreen adjusting wing nut .. .. .	2		1	6
B254/149	Special washer for ditto .. .. .	2		3	
B254/132	Windscreen glass (Triplex) .. .. .	1	1	3	1
B254/151	Dome nut for windscreen swivel .. .. .	2		6	
B254/147	Special washer for ditto (C.P.) .. .. .	2		3	
B254/150	Windscreen rubber surround .. .. .	1	2	0	
B254/152	Stud plate for securing hood to windscreen .. .. .	2	3	0	
B254/153	Wing nut for ditto .. .. .	2	1	0	
<b>HOOD AND SIDESCREENS</b>					
B254/6	Hood complete .. .. .	1	4	14	0
B254/154	Hood frame complete .. .. .	1	1	16	8
B254/177	Hood frame fulcrum bracket on body .. .. .	2		2	9
B254/155	Hood canopy .. .. .	1	3	0	6
B254/156	Hood envelope .. .. .	1	1	2	6
B254/7	Side-curtain with securing brackets O/S .. .. .	1	1	12	0
B254/158	Side-curtain securing bracket O/S (front) .. .. .	1		2	6
B254/159	" " " O/S (rear) .. .. .	1		2	6
B254/8	Side-curtain with securing brackets N/S .. .. .	1	1	12	0
B254/161	Side-curtain securing bracket N/S (front) .. .. .	1		3	0
B254/162	" " " N/S (rear) .. .. .	1		3	0
B254/163	Side-curtain flap O/S .. .. .	1		9	3
B254/164	" " " N/S .. .. .	1		9	3
B254/3	Facia panel (drilled) with beading .. .. .	1	1	15	6
B251/145	Beading for facia panel (C.P.) .. .. .	1		3	10
B254/173	Beading for rear of body (C.P.) .. .. .	1		10	2
B254/9	Toolbox .. .. .	1	2	7	0
<b>BODY DETAILS</b>					
<b>(N.a. Tourer Body) (Illustrations, Pages 39, 40, 41)</b>					
B255	Body complete .. .. .	1	Price on application		
<b>DOORS, LOCKS AND HINGES</b>					
B255/11	Door (upholstered) (less fittings) O/S .. .. .	1	6	17	6
B254/124	Door hinge (top) O/S .. .. .	1		3	8
B254/126	" " (bottom) O/S .. .. .	1		3	8
B254/182	Door hinge pins .. .. .	2		4	
B254/128	Door lock O/S complete .. .. .	1	17	6	



Part No.	DESCRIPTION	No. Used		Price Each		
		2-seater	Tourer	£	s.	d.
B254/179	Door lock striking plate .. .. .	..	1	7	6	
B254/130	Door handle O/S .. .. .	..	1	5	0	
B225/148	Door check strap .. .. .	..	1	2	0	
B235/116	Door rubber buffer, shoe and plate .. .. .	..	2	7		
B254/133	Door rubber buffer (on body) .. .. .	..	1	6		
B224/137	Sidescreeen securing clamp (on door) .. .. .	..	2	2	5	
B255/12	Door (upholstered) (less fittings) N/S .. .. .	..	1	6	17	6
B254/125	Door hinge (top) N/S .. .. .	..	1	3	8	
B254/127	" " (bottom) N/S .. .. .	..	1	3	8	
B254/182	Door hinge pins .. .. .	..	2	4		
B254/129	Door lock N/S complete .. .. .	..	1	17	6	
B254/179	Door lock striking plate .. .. .	..	1	7	6	
B254/131	Door handle N/S .. .. .	..	1	5	0	
B225/148	Door check strap .. .. .	..	1	2	0	
B235/116	Door rubber buffer, shoe and plate .. .. .	..	2	7		
B254/133	Door rubber buffer (on body) .. .. .	..	1	6		
B224/137	Sidescreeen securing clamp (on door) .. .. .	..	2	2	5	
B254/134	Door tread plate O/S .. .. .	..	1	3	10	
B254/135	" " N/S .. .. .	..	1	3	10	
<b>SEAT AND FITTINGS</b>						
B255/1	Front bucket seat with slide and cushion O/S .. .. .	..	1	6	17	6
B255/2	" " " " " " " " N/S .. .. .	..	1	6	17	6
B255/143	" Front bucket seat (upholstered) (less slide and cushion) O/S .. .. .	..	1	4	1	3
B255/142	Front bucket seat (upholstered) (less slides and cushion) N/S .. .. .	..	1	4	1	3
B255/101	Seat cushion .. .. .	..	2	2	3	0
A659	Seat adjusting fitting .. .. .	..	1 pr.	1	6	6
B255/8	Rear seat pan .. .. .	..	1	1	1	3
B252/105	Locating bracket for rear seat pan .. .. .	..	3	1	2	
B252/106	Nut for securing rear seat pan .. .. .	..	3			8
B255/104	Rear seat cushion (less air bags) .. .. .	..	1	8	15	0
B255/105	Air bag for rear seat cushion .. .. .	..	2	1	1	3
<b>FLOORBOARDS AND CARPETS</b>						
B255/138	Floorboard O/S (front) .. .. .	..	1	5	10	
B255/139	" " N/S (front) .. .. .	..	1	5	10	
B255/130	Foot well .. .. .	..	1	5	4	
B255/133	Carpet (gearbox) .. .. .	..	1	2	9	0
B255/134	" (centre) .. .. .	..	2	14	6	
B255/135	" (rear) .. .. .	..	1	1	3	8
B255/136	" (heel well) .. .. .	..	1	16	0	
B254/178	Leather cover for propeller shaft shroud .. .. .	..	1	13	0	
B254/169	Passenger foot slope .. .. .	..	1	8	3	
B220/109	Rubber mat for carpet .. .. .	..	2	2	0	
<b>WINDSCREEN AND DETAILS</b>						
B254/4	Windscreen complete .. .. .	..	1	6	3	0
B254/5	Windscreen frame complete (less glass) .. .. .	..	1	4	10	0
B254/143	Windscreen frame (bare) .. .. .	..	1	1	10	0
B254/144	Windscreen side support (bottom) O/S .. .. .	..	1	18	6	
B254/145	" " " (bottom) N/S .. .. .	..	1	18	6	
B254/146	" " " (top) .. .. .	..	2	4	6	
B254/148	Windscreen adjusting thumbscrew .. .. .	..	2	1	6	
B254/149	Special washer for ditto .. .. .	..	2			3
B254/151	Dome nut for windscreen swivel .. .. .	..	2			6
B254/147	Special washer for ditto .. .. .	..	2			3
B254/132	Windscreen glass .. .. .	..	1	1	3	1
B254/150	Windscreen rubber surround .. .. .	..	1	2	0	
B254/152	Stud plate for securing hood to windscreen .. .. .	..	2	3	0	
B254/153	Wing nut for ditto .. .. .	..	2	1	0	
<b>HOOD AND SIDESCREENS</b>						
B255/3	Hood complete .. .. .	..	1	5	0	0
B255/106	Hood frame complete .. .. .	..	1	2	16	9
B254/177	Hood frame fulcrum bracket (on body) .. .. .	..	2	2	9	
B255/107	Hood canopy .. .. .	..	1	2	5	0
B255/108	Hood envelope .. .. .	..	1	1	2	6
B255/109	Hood straps .. .. .	..	2	2	9	
B255/110	Hood strap staples .. .. .	..	2	1	0	
B255/111	Hood rest (rear) O/S .. .. .	..	1	3	4	
B255/112	" " (rear) N/S .. .. .	..	1	3	4	
B255/4	Front side-curtain with securing brackets O/S .. .. .	..	1	1	10	8
B255/115	Securing bracket for ditto (front) .. .. .	..	1	3	8	
B255/116	" " " " (rear) .. .. .	..	1	3	8	
B255/5	Front side-curtain with securing bracket N/S .. .. .	..	1	1	10	8
B255/118	Securing bracket for ditto (front) .. .. .	..	1	3	8	
B255/119	" " " " (rear) .. .. .	..	1	3	8	

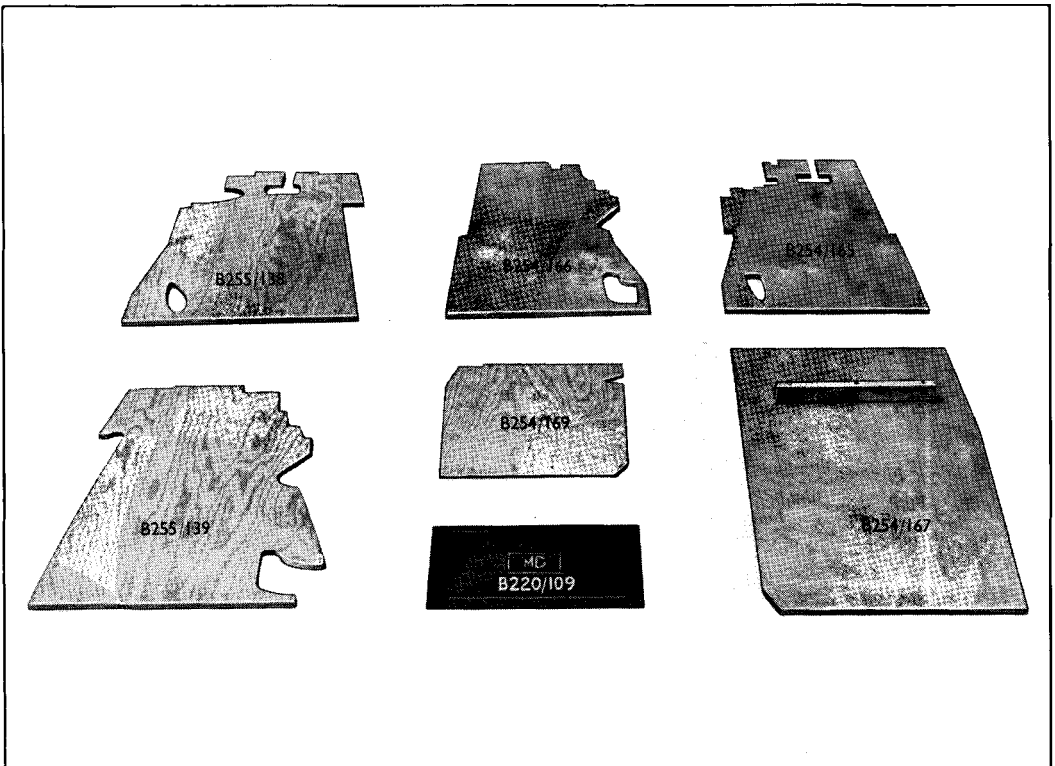
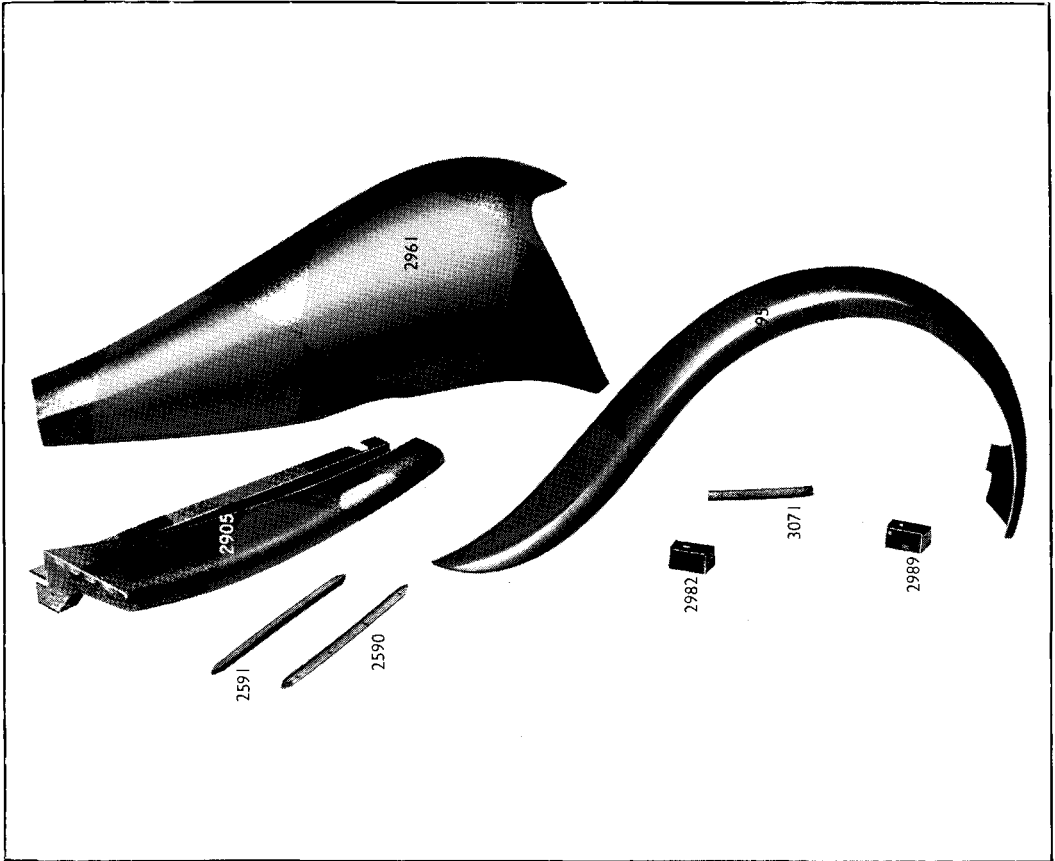



**When ordering Parts be sure they are genuine M.G.**

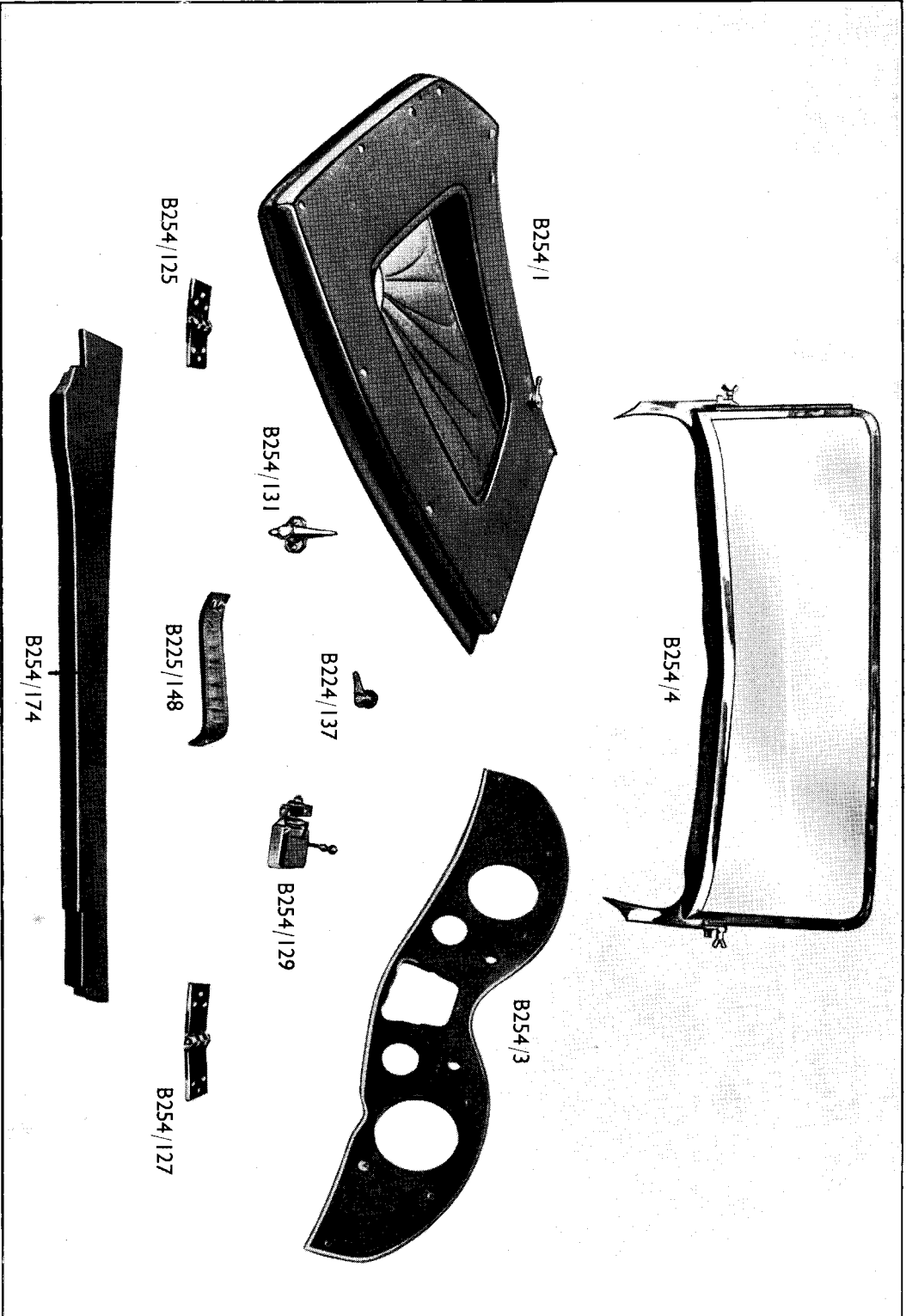

Don't forget to quote the Chassis and Engine Numbers.



Part No.	DESCRIPTION	No. Used		Price Each		
		2-seater	Tourer	£	s.	d.
B255/6	Rear side-curtain with securing bracket O/S .. .. .	1		1	6	0
B255/121	Securing bracket for ditto .. .. .	1		3	8	
B255/7	Rear side-curtain with securing bracket N/S .. .. .	1		1	6	0
B255/123	Securing bracket for ditto .. .. .	1		3	8	
B224/137	Securing clamp for rear side-curtains (on body) .. .. .	2		2	5	
B255/124	Locating socket for rear side-curtains (on body) .. .. .	2		2	9	
B254/3	Facia panel (drilled) with beading .. .. .	1		1	15	6
B251/145	C.P. beading for facia panel .. .. .	1		3	10	
B255/9	C.P. beading for rear of body O/S .. .. .	1		5	4	
B255/10	" " " " " " N/S .. .. .	1		5	4	
B254/9	Toolbox .. .. .	1		2	7	0
<b>TOOL KIT</b>						
P330/100	Tool roll .. .. .	1	1	4	0	
P330/101	Screwdriver (10") .. .. .	1	1	1	6	
P330/103	Adjustable spanner .. .. .	1	1	2	8	
P330/104	Pliers (6") (pair) .. .. .	1	1	1	0	
P330/113	Spanner ( $\frac{1}{4}$ " x $\frac{3}{16}$ " double-ended) .. .. .	1	1		6	
P330/114	" ( $\frac{3}{8}$ " x $\frac{1}{4}$ " double-ended) .. .. .	1	1		10	
P330/115	" ( $\frac{1}{2}$ " x $\frac{7}{16}$ " double-ended) .. .. .	1	1	1	3	
1733	Contact breaker spanner with .015" feeler gauge .. .. .	1	1		6	
1734	Grease gun (for group system) .. .. .	1	1	10	6	
1735	Tyre pump .. .. .	1	1	7	0	
P330/117	Hammer for Rudge hubs .. .. .	1	1	6	6	
A288	Grease gun (for propeller shaft) .. .. .	1	1	6	0	
2368	Cylinder head spanner .. .. .	1	1	2	6	
2372	Plug spanner .. .. .	1	1	2	9	
1959	Spanner ( $\frac{1}{8}$ " Whit. single-ended) .. .. .	1	1		10	
1736	Jack with handle (Shelley double-lift type) .. .. .	1	1	1	1	0
2742	Sump drain plug spanner .. .. .	1	1	1	3	
2801	Box spanner ( $\frac{1}{4}$ " Whit.) .. .. .	1	1		11	
2802	Box spanner ( $\frac{7}{16}$ " Whit.) .. .. .	1	1	1	3	
3070	Box spanner ( $\frac{9}{16}$ " Whit. x 7" long) .. .. .	1	1	1	3	
2860	Tommy bar for Part Nos. 2801, 2802 & 3070 .. .. .	1	1		2	
2867	Tappet spanner with .006" feeler gauge .. .. .	1	1	1	0	
2008	Starting handle .. .. .	1	1	5	6	

