

Price 10/- net

The Instruction Manual

for the



Magnette

(KN Series)

FIRST EDITION - - OCTOBER, 1934

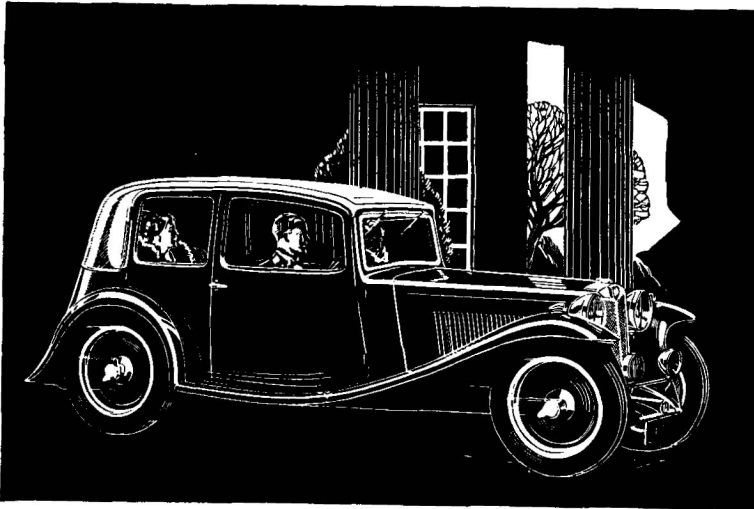

Illustration No. 1.—The M.G. Magnette KN Pillarless Saloon

TELEGRAMS
E M G E E
ABINGDON
TELEPHONE
251 (3 LINES)
ABINGDON
ON-THAMES

THE  CAR
COMPANY LTD
ABINGDON-ON-THAMES

GOVERNING
DIRECTOR
... LORD ...
NUFFIELD
MANAGING
DIRECTOR
CECIL KIMBER
1934



FOREWORD.

The object of this Instruction Book is to place the owner in possession of as much detailed information as possible for the maintenance of the M.G. Magnette "KN" type Four-door Saloon.

First of all details are provided regarding running-in, and in the later chapters the various items of the car, such as chassis, engine, brakes, carburettors, etc., are dealt with under separate headings. Each section contains more detailed information than is needed for ordinary maintenance, which it is hoped will prove of interest to owners, and of assistance to service stations.

The time arises when a car has to be dismantled, and it is then that the reference to the detailed instructions can be of considerable value, as they point out both to the owner and repair shops, unacquainted with the construction of the car, the correct method of procedure.

We cannot stress too highly the danger of fitting non-genuine parts to M.G. cars.

Unfortunately cases have come to our notice where accidents have actually been caused by this practice, and we strongly advise all M.G. owners to insist and see that for all repairs and replacements only genuine M.G. parts are fitted.

M.G. parts are specially designed and manufactured to withstand the stresses imposed by a high-speed sports car, and we would warn all owners that the fitting of non-genuine parts renders the guarantee *null and void*.

POSTAGE AND PACKING CHARGES. The prices quoted in the Spare Parts List are nett at the Distributors' or Dealers' premises, but in the event of parts having to be forwarded, packing and posting charges will of course be extra. Except in the case of those who have opened approved accounts, all parts that can be will be forwarded C.O.D.

Should at any time the owner fail to find the particular information he requires in the Instruction Book, it is hoped he will not hesitate to communicate with the Service Department at Abingdon (being sure always to quote the car's chassis and engine numbers), who will always be only too ready to afford any assistance they can at any time.

G.K. — G.T.

October, 1934.

MISCELLANEOUS HINTS.

- Do** read this *Manual* thoroughly and carefully, and follow out the instructions laid down.
- Do** always quote model, year, engine and chassis number when writing. **This is very important.**
- Do** free the engine by hand when cold before using the starter.
- Do** remember to keep the radiator filled.
- Do** carefully run-in a new engine ; restraint during the first 2,000 miles will be handsomely repaid.
- Do remove the oil filter element and replace with a new one at the end of the first 1,000 miles, and subsequently every 10,000 miles.**
- Do** change the engine oil after the first 500 miles and every 1,000-1,500 miles thereafter.
- Do** use the gears freely, particularly on hills and when accelerating after corners, in traffic, etc.
- Do** specify the genuine M.G. parts when ordering spares, the use of "pirate" parts is certain to lead to serious breakdowns, and renders the guarantee null and void.
- Do** check the tyre pressure every week, and inflate to the pressure recommended on page 4.
- Do** avoid "harsh" driving, particularly when braking ; the M.G. brakes are smooth and powerful and need never be "stamped on."
- Do,** please, drive slowly when in the vicinity of the factory when you come to visit us.
- Do** study the oil chart at the back of the book and attend to the chassis, etc., at the periods stated.
- Do** write to us or come and see us (by appointment, please) when in any difficulty.
- Do not** under any circumstances allow the oil level to fall below half full ; it is best to keep it always up to three-quarters at least.
- Do not** mix different brands of oil in the sump.
- Do not** race the engine when it is cold ; this will shorten considerably the life of pistons and bearings, and may even result in piston seizure. At the same time do not allow it to idle, this is equally injurious. The best warming-up speed is about 1,000-1,500 r.p.m.
- Do not** allow the engine to labour.
- Do not** run the engine with the mixture control in the rich position longer than necessary.
- Do not** forget to lubricate clutch thrust.
- Do not** slip the clutch except when actually starting off or changing gear ; change down in traffic, to bottom gear if necessary.
- Do not** forget to turn the petrol tap back to the main position after refilling the tank.
- Do not** leave the headlamps alight when the car is stationary at night ; this drains the battery unnecessarily and is very discourteous to other road users.
- Do not** forget to top-up the battery with distilled water regularly.
- Do not** lean on open doors.
- Do not** subject the tyres to glancing blows from the kerb when drawing up beside the pavement ; this may interfere with wheel alignment and have a serious effect on steering and tyre life.

GENERAL DATA.

THE M.G. MAGNETTE SALOON

KN Type (6-cylinder).

Bore	-	-	-	-	-	-	-	-	-	57 m/m
Stroke	-	-	-	-	-	-	-	-	-	84 m/m
Capacity	-	-	-	-	-	-	-	-	-	1287 c.c.
Horse Power (R.A.C. Rating)	-	-	-	-	-	-	-	-	-	12.08
Sump capacity	-	-	-	-	-	-	-	-	-	1½ Gallons approx.
Firing order	-	-	-	-	-	-	-	-	-	1-4-2-6-3-5
Capacity of water system	-	-	-	-	-	-	-	-	-	3 Gallons

PETROL TANK CAPACITY - - - - - 10 Gallons approx.
Reserve supply in main tank, two gallons.

DIMENSIONS :—

Overall length	-	-	-	-	-	-	-	-	-	12' 10½"
„ width	-	-	-	-	-	-	-	-	-	4' 11"
„ height	-	-	-	-	-	-	-	-	-	5' 0"
Wheelbase	-	-	-	-	-	-	-	-	-	9' 0"
Track	-	-	-	-	-	-	-	-	-	4' 0"
Weight	-	-	-	-	-	-	-	-	-	2½ cwt.

Tyre pressures - - - - - 32 lb. all tyres

Gearbox Ratios.	Overall Ratios.	Speeds at 1,000 r.p.m.
TOP - - -	5.78 to 1	14.15 m.p.h.
THIRD - - -	7.85 to 1	10.4 m.p.h.
SECOND - - -	13.4 to 1	6 m.p.h.
BOTTOM - - -	24.2 to 1	3.4 m.p.h.
REVERSE - - -	24.2 to 1	—
REAR AXLE RATIO - - -	5.78 to 1	

(See chart of speeds on gears against engine revolutions on page 51.)

VALVE TIMING —

Inlet opens 15° before T.D.C. Closes 55° after B.D.C.

Exhaust opens 50° before B.D.C. Closes 20° after T.D.C.

SECTION A

GENERAL CHASSIS DATA



Recommended and Approved Oils

Running-in a new car—the first 2000 miles

Chassis Lubrication

The Suspension and Shock Absorbers

Rear Axle and Differential

Propeller Shaft and Universal Joint

Tyres and Rudge Road Wheels



CAR NO.

ENGINE NO.

TELEGRAMS: ENCEE ABINGDON.
PHONE: ABINGDON 251.

ANY QUESTION AFFECTING THE GUARANTEE ATTACHED TO THIS CAR TO BE REFERRED (VIA THE AGENT FROM WHOM THE CAR WAS PURCHASED) TO THE MANUFACTURERS

The M.G. Car Company LTD. Abingdon-on-Thames

CHANGE OIL COMPLETELY EVERY 1500 MILES.
GUARANTEE CEASES ON REMOVAL OF THIS PLATE.

The Guarantee Plate is to be found on the engine side of the bulkhead on the near side.

EVERY M.G. IS TESTED ON DUCKHAM'S OIL, AND WE STRONGLY RECOMMEND ITS USE BOTH IN SUMMER AND WINTER.

ENGINE	SUMMER	WINTER	GEARBOX	BACK AXLE
Duckham's Adcol	N.P.5	N.P.3	Gear oil N	Gear oil N
On the rare occasions when Duckham's oils cannot be obtained the following are approved for use :—				
Wakefield ... Filtrate ... Mobiloil ... Essolube ... Price's Motorine ... Shell ... Speedolene ... Sternol ... Texaco ...	Castrol XXL ... Super ... D ... 50 ... " C " de Luxe ... Aero or Triple ... " Aero " ... WW Aero ... Airplane 100 ...	Castrol XL ... Super ... AF ... 40 ... " C " de Luxe ... Aero or Triple ... " Aero " ... WW Aero ... Airplane 100 ...	Swanshot ... Gear oil ... CW ... Super gear oil ... Amber B. ... Gear oil ... " H " ... Liquid Ambroleum ... Thuban ...	Swanshot ... Gear oil ... C ... Super gear oil ... Amber B. ... Gear oil ... " H " ... Liquid Ambroleum ... Thuban ...

Compounded oils must not be used.

Hub Grease : **Duckham's Adcol H.B.B.**

Universal Joints and Clutch Thrust Race : **Duckham's Hardy Spicer Grease.**

By far the cheapest way of buying engine oil is in five gallon drums, which can always be supplied by accredited agents. Keep the receptacle used for filling perfectly clean.

CHANGE THE ENGINE OIL AFTER THE FIRST 500 MILES AND AGAIN AFTER THE FIRST 1000 MILES HAVE BEEN COMPLETED, AFTER WHICH THE OIL SHOULD BE RENEWED EVERY 1000—1500 MILES.

Running-In.—The importance of very carefully running-in a new engine of the high revving type cannot be over-emphasized.

IT IS OF THE UTMOST IMPORTANCE THAT THE ENGINE SHOULD NOT EXCEED THE FOLLOWING SPEEDS ON ALL GEARS FOR THE FIRST 2,000 MILES.

FOR THE FIRST 1,000 MILES - - - - 2,000 r.p.m.

FROM 1,000-1,500 MILES - - - - 2,800 r.p.m.

FROM 1,500-2,000 MILES - - - - 3,500 r.p.m.

AND THESE SPEEDS ONLY WHEN THE OIL HAS BECOME THOROUGHLY WARM.

Always allow the engine to warm up for 15 minutes at least at about 1,000 r.p.m.; this ensures adequate cylinder wall lubrication while the oil is thick; also do not use the choke any longer than is necessary since the rich mixture will wash the oil from the cylinder walls.

The mixture and slow running controls are mounted on the gearbox remote control.

The use of upper cylinder lubricant is considered beneficial during the running-in period, it should be mixed with the fuel in the proportion recommended by the supplier—any of the well-known brands are suitable.

No particular fuel is specified, but the carburetters are tuned for the use of Ethyl petrol or a Benzole mixture.

The engine should be decarbonized after the first 2,000 miles, but before doing so read carefully the instructions on pages 20-28.

Even when run in it is inadvisable to run a cold engine fast until the oil has had an opportunity of circulating and warming up sufficiently in order to run freely through the oil passage ways throughout the engine. This avoids excessive piston and cylinder wear, and lengthens considerably the period before which a re-bore is necessary.

Lubrication.—One of the first things the owner should pay special attention to is the various lubricants recommended for use in the engine—there is a list on page 6.

The oil level in the sump is determined by a dip-stick which is situated above the sump on the off-side. When checking the oil level, first remove and wipe the dip-stick, re-insert and then again remove and take the reading.

Engine lubrication is pressure throughout by gear type pump which sucks oil from the sump through an internal gauze filter, and feeds it via a Tecalemit oil filter to the main and big-end bearings and the valve gear.

After the first 500 miles the engine oil should be drained and the sump refilled with new oil, at the same time the gauze filter in the sump should be removed and washed thoroughly in petrol. **The oil should again be changed after the first 1,000 miles have been covered**, and in addition to cleaning the sump filter the Tecalemit filter should be removed bodily by disconnecting the oil pipes and the securing bolts holding it to the cylinder block; when removing the filter be careful not to damage the washer.

Before replacing the filter it should be cleaned thoroughly in petrol, and the old element thrown away and replaced by a new one.

Engine oil should afterwards be changed every 1,000-1,500 miles, the Tecalemit oil filter element need not, however, be changed more often than every 10,000 miles.

Under no circumstances should paraffin be used to wash out the lubricating system of the engine. More detailed instruction on the lubricating system will be found in the engine section, part of which deals with the complete travel of the oil from the sump to the pump, thence through the various pipes and passages in the engine to the main and big-end bearings and to the overhead valve gear. The oil pump is provided with a relief valve of very simple construction, consisting of a spring and plunger. The details of this will also be found on page 34.

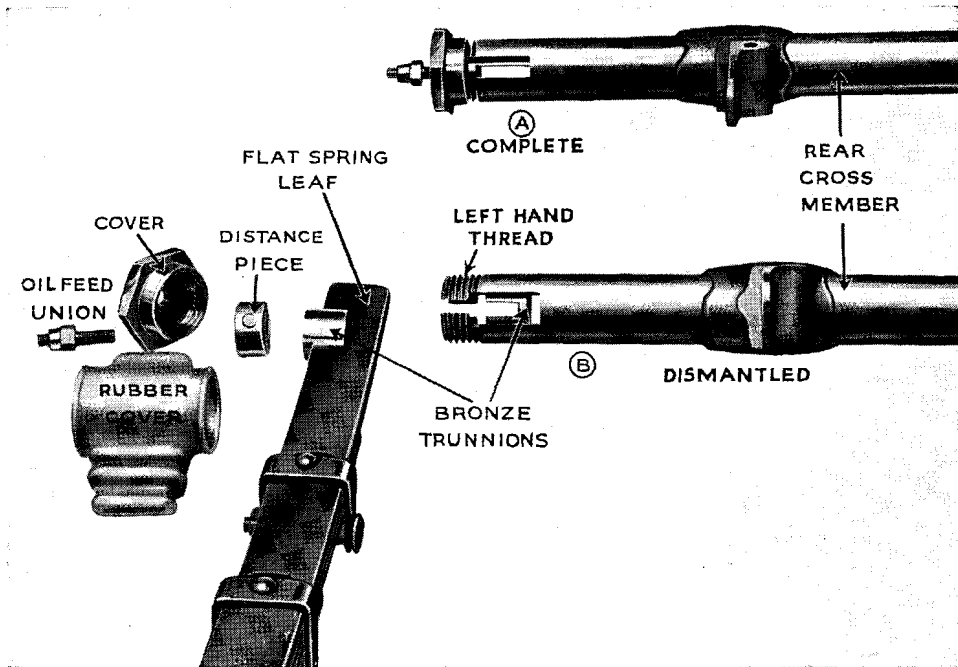

Illustration No. 3.—Details of the road spring trunnion bearing and the point of lubrication.

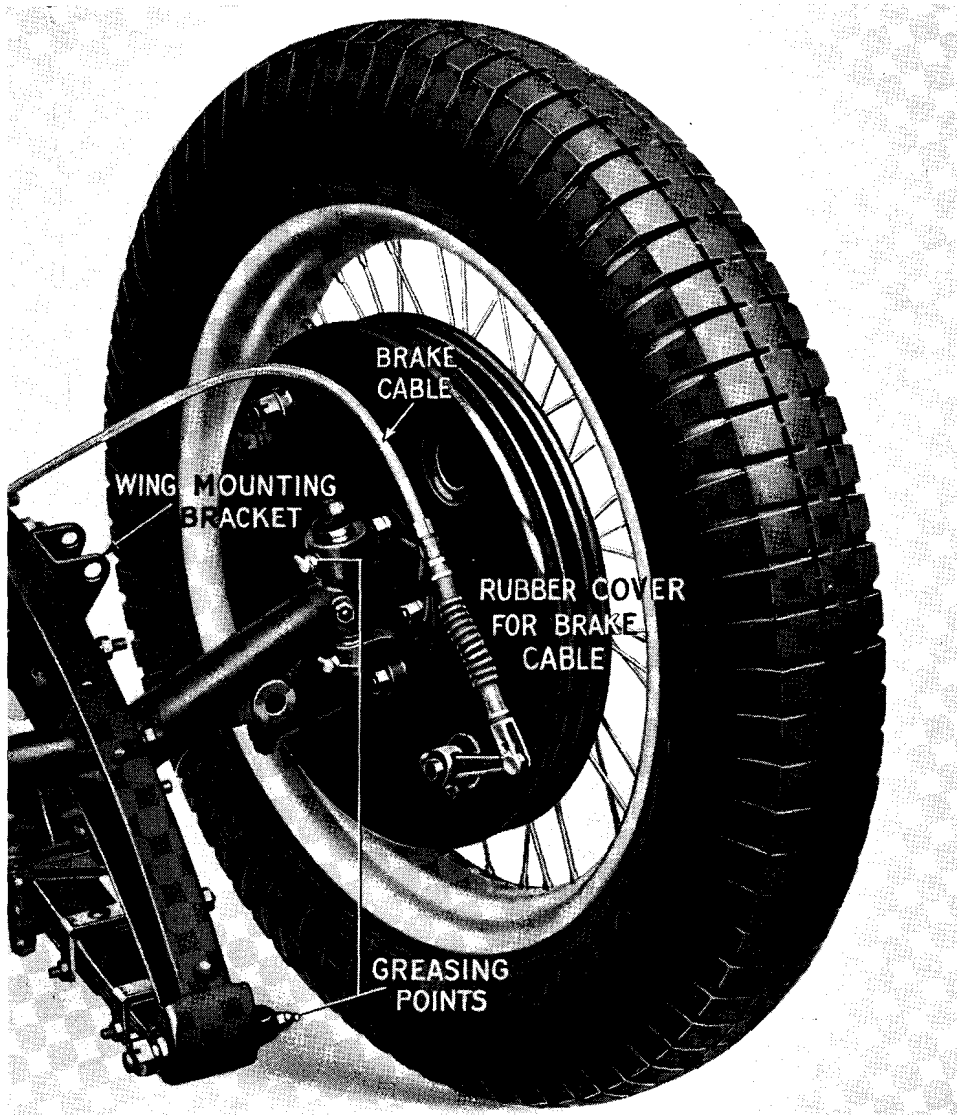

Illustration No. 4.—Lubrication points of the steering head are marked. In addition, the greasing point on the end of the track rod (not shown in the illustration) needs attention, as well as the three points where the track rod is divided. (See oil chart).
 Page Eight

Chassis Lubrication and Suspension.—Most of the chassis fittings are conveniently lubricated from 6 oil nipples, 3 on either side of the car, which are to be found on the brackets supporting the dashboard. The bonnet has to be lifted and the nipples fed by a large oilgun provided with the car. Reference to the plates attached to the dashboard (Illustration 5) shows that on the off-side of the car there are nipples marked A, B and C, and on the near-side of the car nipples D, E and F. The points lubricated by these various nipples are the brake cables, the spring trunnions, the steering box and column and the brake cross shaft. The rear ends of the front and rear springs slide in phosphor-bronze blocks in the spring anchorages.

Suspension.—The front ends of both front and rear springs are pivoted upon fixed points. As a spring compresses or expands, due to load or riding over inequalities, the rear end of the spring slides to and fro. The manner in which this is effected is shown in Illustration No. 3, which shows a rear tubular frame cross member with the phosphor-bronze slotted bushes in position. These are held in place by a distance piece and the whole assembly locked up by a large nut. A greaser connection, fed from C or F on the dash wall, is provided which screws into the distance piece, and finally the whole assembly is enclosed by means of a moulded rubber cover as seen in the illustration. The bronze bushes are capable of rotating inside the tube and the spring is also capable of end movement in the slots of the bushes. It is advisable periodically to hoist the car so that the load is taken off the springs, and after first thoroughly cleaning them to lubricate the spring leaves with penetrating oil. The steering head pins, the track rod and other steering ball socket joints are lubricated separately. **Only use Duckham's gear oil in the large oilgun.**

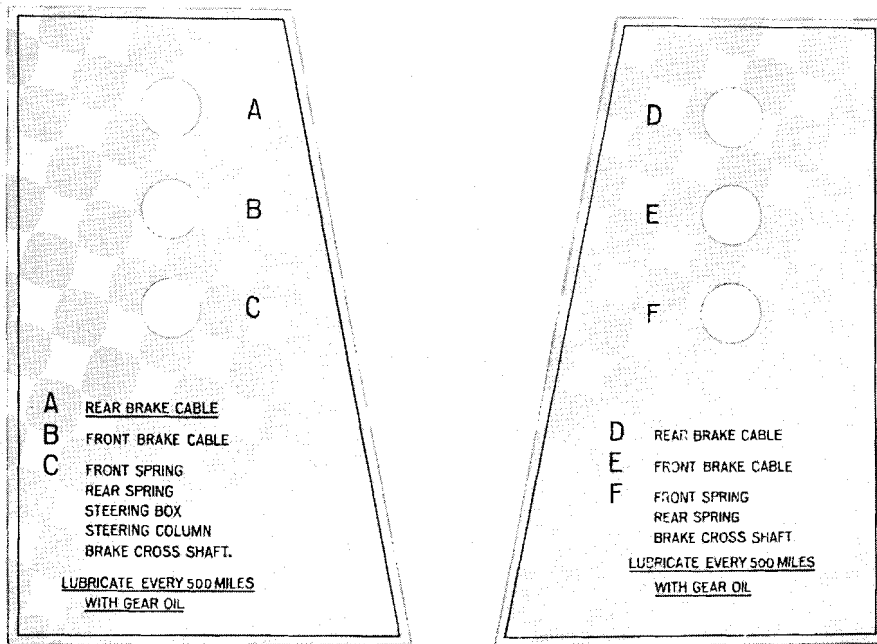

Illustration No. 5.—The plates indicate the various points dealt with from the centralised nipples.

A lubricating chart is provided at the end of the book indicating the lubrication carried out from the central dashboard nipples, and the other points on the chassis that have to be individually lubricated. **The only point which cannot normally be seen is the clutch thrust lubricator, but this will be dealt with on page 48, from which it follows that the clutch inspection cover has to be removed before the thrust can be lubricated. This requires attention every 2,000 miles.**

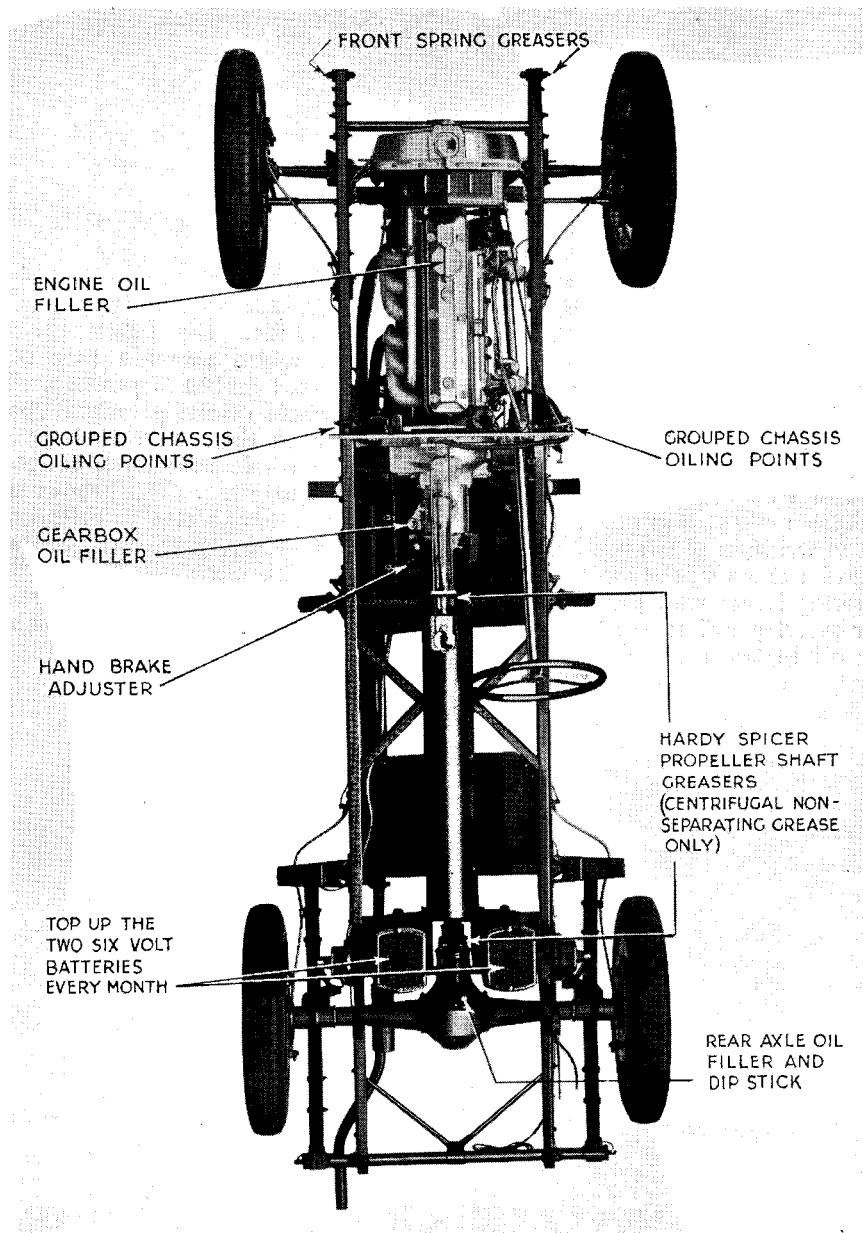

Illustration No. 6.—A chassis plan with reference to various items which cannot readily be seen when the body is mounted, also to a number of oiling points, especially those which are not dealt with by the central chassis nipples.

Universal Joint and Propeller Shaft.—The tubular propeller shaft is fitted at either end with Hardy Spicer universal joints. The front end of the propeller shaft is splined and fits inside the end of the universal joint. The object of this is to allow for the end movement of the propeller shaft due to the flexion of the rear springs and the rise and fall of the axle.

It is necessary to keep this sliding coupling joint lubricated. A nipple for this purpose is provided, access to it being obtained through a hole in the shaft tunnel. The universal joint proper consists of a plate carrying two jaws, a cross head with hardened steel roller bushes, and the opposite set of jaws attached to the propeller shaft.

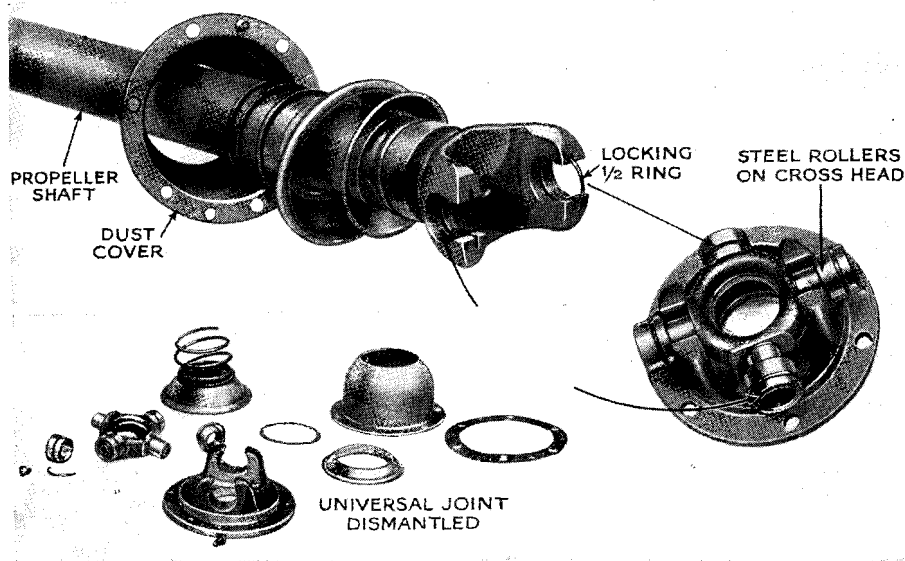

Illustration No. 7.—Various components of the Hardy Spicer universal joint. On the right-hand side is the flange having two jaws and carrying the cross head of the universal joint on steel rollers, the other two pins of the cross head being supported in the jaws of that portion of the joint which is attached to the propeller shaft. To prevent the steel rollers from being flung outwards the jaws are supplied with half rings which fit into the grooves on the rollers. The whole of the universal joint is entirely enclosed by covers held in position by a spring.

This can be seen by referring to Illustration No. 7. The entire universal joint is enclosed by a pressed steel cover and a spring-loaded dust excluder cover. The hardened steel rollers are grooved to receive semi-circular wire rings which prevent them floating outwards. It is essential that this joint should be packed with Duckham's Hardy Spicer grease, using the small gun provided in the tool kit. See chassis lubrication chart at the back of the *Manual*. When applying grease it is necessary first of all to move the car, thus turning the propeller shaft, until the nipples are in the centre of their holes in the shaft tunnel.

Rear Axle.—The casing consists of a steel stamping forming what is known as the "banjo." The complete differential assembly including the driving bevel and crown wheel are mounted on the front cover-plate. The front housing carries the oil filler and oil level dipstick. A drain plug is provided beneath the axle for draining from time to time.

Access to the rear axle for filling purposes is obtained by removing the rear seat pan.

ON NO ACCOUNT OVERFILL THE REAR AXLE. THE CORRECT LEVEL IS MARKED ON THE DIPSTICK.

Rear Wheel Bearing Lubrication.—These bearings have periodically to be lubricated, which is effected by forcing a little grease through a nipple on the inside of each hub recess. Under no circumstances should gear oil be used for this bearing, but on the other hand a grease of the nature of vaseline is essential, as for example Duckham's H.B.B. This grease will remain in the bearing and not be flung out and find its way on to the brakes.

Axle Dismantling.—First remove the wheels and brake-drums. The hub and half-shaft can be withdrawn by refitting a wheel and pulling outwards, and the view obtained in Illustration No. 8 will be visible. This shows that the axle shaft passes through the hollow axle casing, and the inner hub flange runs on a large ball bearing. The ball bearing is secured on the axle tube by means of a ring nut locked by a tab washer. The near side ring nut has a left-hand thread and the off side a normal right-hand thread. Special oil seals prevent the oil in the differential housing from finding its way along the half shafts and on to the brake linings.

Differential.—After the axle shafts have been withdrawn it is possible to remove the complete differential. The helical cut crown wheel is shown on the illustration, after having been removed from the housing and the bridge pieces which hold it in position. The driving bevel assembly runs on three ball bearings, the two inner ones are specially paired. Under no circumstances must one be replaced by a new one without replacing the other one also. (They are always supplied in pairs.) A number of shims are provided to take care of the correct meshing of the driving bevel with the crown wheel. The rear end plate enclosing the whole assembly is provided with tapped holes $\frac{1}{4}$ in. B.S.F. to act as means of withdrawal. If ever the differential assembly needs attention it is advised that the whole unit should be returned to the Factory, where it can be properly looked over and correct adjustment of the gears be effected.

Front Axle.—Duckham's Adcol HBB or similar grease should be used to lubricate the front wheel bearings ; no grease nipple is fitted at this point, and lubrication is effected by placing a small quantity of grease inside the hub recess. The other oiling points on the front axle which need attention are dealt with on pages 8-9-10.

Hartford Shock Absorbers fitted on the front axle are of the friction type. These are correctly set for average loads before the car leaves the Works, but a little looseness may become apparent after the first few hundred miles, rendering adjustment necessary. This is effected by means of the large hexagon nut with pointer attached, which is turned *clockwise* (ordinary right-hand thread) to tighten the shock absorber. The dial is graduated 0, 2, 4, 8, and the pointer should not be moved more than one degree at a time, testing repeatedly (preferably at speed on a rough road) until the best setting is found. It is important that the two Hartfords on the front axle be equally adjusted, and they must on no account be lubricated at any point. Don't over-tighten shock absorbers ; there is nothing to be gained by doing so, and if locked up solid, heavy strain is put on to the mounting brackets.

Luvax Hydraulic Shock Absorbers fitted to the rear axle should be "topped-up," if necessary, every 8000—10,000 miles with Luvax Official Shock Absorber Fluid (if it is absolutely impossible to obtain this fluid, pure castor oil may be used as a temporary substitute) to bring the level to within about $\frac{3}{4}$ in. of the top. It is essential that the recuperator chamber must not be allowed to become empty, otherwise air will enter the working chamber and impair the action of the shock absorber. Do not fill quite full, as the expansion due to temperature increase may set up a pressure which is harmful and unnecessary.

If it is desired to increase the amount of damping and tighten the shock absorber, the regulator screw beneath the filler plug must be turned to the right, thus closing the valve. To decrease the amount of damping the screw is turned to the left, opening the valve and permitting a more free flow of fluid. A very fine degree of adjustment can be obtained, and it is sufficient to turn the regulator screw a quarter turn (one flat) at a time and ascertain, by road tests, if sufficient adjustment has been made.

If the original setting has been entirely lost, then by disconnecting the bottom end of the connecting link and moving the lever by hand the shock absorbers can be balanced up by individual adjustment. The best amount of damping can be determined by road test with the shock absorbers reconnected.

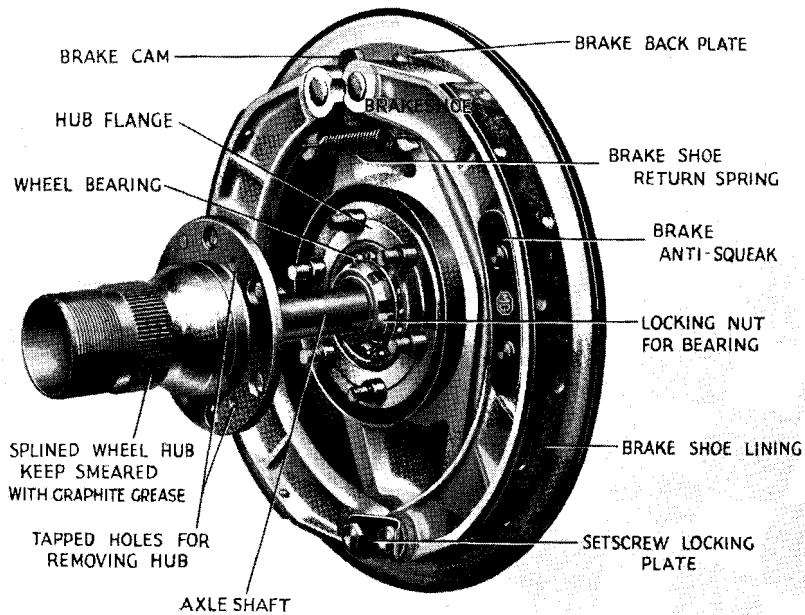

Illustration No. 8.—General view of the rear hub partially withdrawn from the axle. The hub runs on a ball bearing and is locked in position in the hub flange by means of a castellated nut and tab washer. The brake pull-off springs will be noticed.

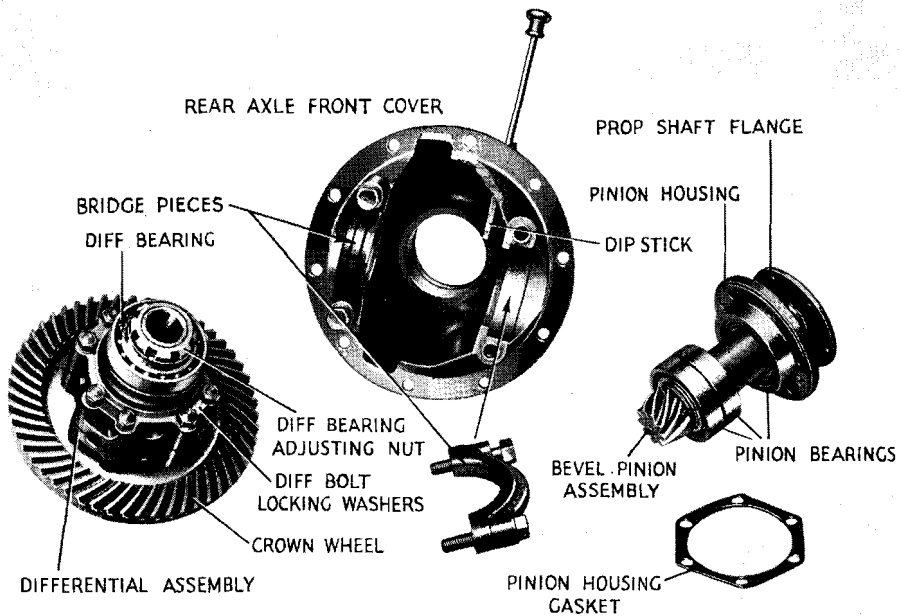

Illustration No. 9.—The components of the differential, showing the latter removed from the housing.

Tyres.—The tyres, being one of the most expensive items in the upkeep of a car, should have special attention in order that you may receive the utmost service from them.

The most important factor is the maintenance of the correct air pressure, and this should be checked regularly in all five tyres with a reliable pressure gauge once every week, whether the car is used or not. Remember that it is the air that carries the load.

Dunlop tyres are fitted, and the makers' recommended pressures are as follows :—

Tyre size.	Inflation Pressures (lb. per square inch).	
	Front Tyres.	Rear Tyres.
4.75—19	32	32

These pressures, if desired, may be reduced by 4 lb. per square inch if the car is to be driven at low average speeds.

Oil and Grease.—Tyres should never be allowed to stand in a pool of oil, grease or petrol, as these substances are detrimental in their effects on rubber. Any oil or grease should be removed from the tyre as soon as it is noticed by the use of a rag.

To remove Tyre.—First deflate by removing all the valve parts and push both cover edges into the well of the rim at the part diametrically opposite the valve, then lever the cover edges near the valve over the rim edge. No force is required to do this, but the edges of the cover opposite the valve must be in the well of the rim.

To fit Tyre.—Push one edge of the cover over the edge of the rim. It will go quite easily if the part first put on is pushed right down into the well of the rim.

Very slightly inflate the inner tube, do not distend it, place it in the cover with the valve through the hole in the rim. Fit the second edge of the cover, starting at a point diametrically opposite the valve and pushing the edge down into the well of the rim. If this is done the last few inches can be fitted without using levers.

If levers are used do not use force, as this may damage the beads of the tyre.

When inflating see that the edges of the cover are seated evenly round the rim. This can be checked by the line provided on the cover.

THE RUDGE-WHITWORTH centre-lock wheel system provides the most rapid method of changing road wheels. Like all mechanical devices, it must be properly treated in order to give 100 per cent. service. Observation of the following quite simple hints will ensure complete satisfaction :—

(a) **When the car is new.**—After the first long run, or after fifty miles of short runs, jack up each wheel and hammer nuts to ensure that they are tight.

(b) **When wheels are replaced,** cover both conical surfaces and the serrations in the hub, also the coned surface and threads in the lock-nut, with a light coating of grease. Hammer tight and repeat as when car is new.

(c) **When a forced change is made on the road,** remove and grease the hub as soon as convenient.

(d) **Once in twelve months** remove wheels for examination and re-greasing.

(e) **When changing wheels** wipe the serrations and cones on hub, wheel and lock-nut to remove any foreign matter that would prevent the wheel from properly seating. Rust and dirt are the enemies of all mechanical devices.

(f) **After general overhaul** of car, which may involve stripping of axle, the inscription on the lock-nuts should be checked to see that it corresponds with the side of the car on which it is applied.

GENERAL.—Always hammer the lock-nuts tight. Lift car on jack before using the hammer. The lock-nuts are designed for self-locking ; but should not on that account be permitted to run untightened, because there is, in such case, a possibility of damaging the splines.

SECTION B

THE BRAKES

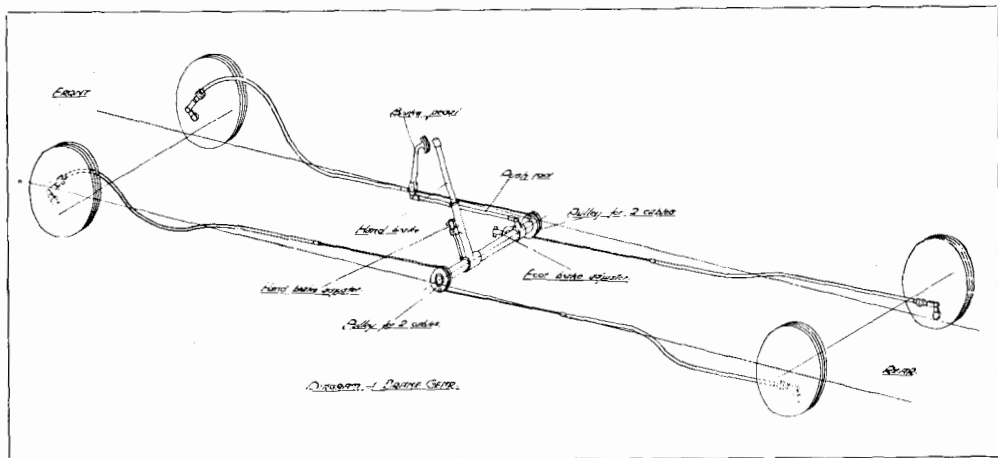

Illustration No. 10.—This sketch shows diagrammatically how the brakes are applied through the medium of cased steel cables.

Independent Adjustment, Brake Anti-squeak Device

DON'T NEGLECT BRAKE MAINTENANCE. IT'S DANGEROUS TO DRIVE A FAST CAR LIKE THE M.G. WITH THEM OUT OF ADJUSTMENT.

Brakes.—The brakes are applied through the agency of steel cables which pass through metal sheathed rubber-covered outer cables from either side of the centre of the chassis to the brake-drums. The sketch shows diagrammatically how the brakes are applied. A cross shaft is placed in the middle of the chassis anchored at either end and supported in the centre by a tubular cross member of the frame. This can be seen by referring to Illustration No. 10, which also illustrates the hand brake. The lever is situated on the near-side of the gearbox, and towards the base an extension will be found on which there is a thumb nut. The foot brake adjustment is on the off-side of the car, forward of the driver's seat (see illustration No. 12).

The foot brake pedal is coupled to the brake actuating cross shaft by a rod, and either extremity of the brake cross shaft is provided with a pulley having holes drilled through it top and bottom to receive the end adapters of the brake cables. As either brake is applied, the brake cross shaft is rotated, pulling the brake rear cables forward, and the front brake cables backwards.

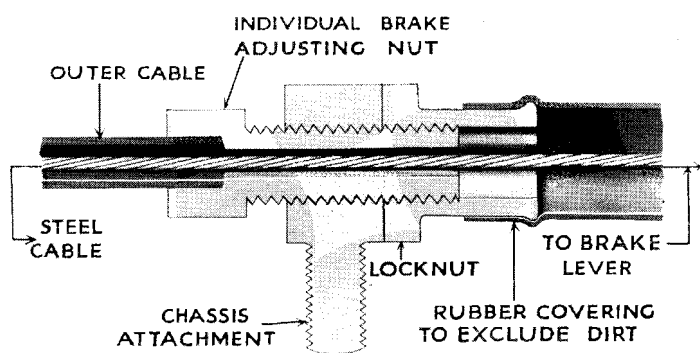

Illustration No. 11.— The brake cable stop and individual adjustment fitted on the brake drum back plates.

Independent Adjustment.—Should it be necessary to adjust the brakes independently this can be done by means of adjusting screws fitted to the cable stops on the axle back plates. At this point on the cables a rubber dirt excluder is fitted in the form of a rubber tube, and this tube is mounted on what is actually the lock nut for this adjustment.

By undoing this lock nut the cable stop can be adjusted on its thread by the amount required and the lock nut re-tightened.

The whole of the brake cross shaft is lubricated from the dash wall nipples, and in order to give perfect freedom for the rotation of the cross shaft it is mounted at one end on what are termed needle bearings. These are shown in Illustration No. 12. Should it ever become necessary to remove the cross shaft, on refitting the needle bearings can be reinserted by covering the bush with grease and embedding the bearings in it, they will then stop in position while the bush is replaced in the cross shaft. At this point reference should again be made to Illustration No. 12.

The front and rear brake-drums of the car are identical in design. It is necessary from time to time to remove the brake-drums in order to clean out the brakes or have them re-lined. The procedure is very simple. When the wheel is removed take off the nuts, removing also the countersunk grub screws, and after releasing the brake, the drum can be withdrawn by a slight tapping on the edge of the drum with a wooden mallet or a piece of wood and a hammer.

Removal of the countersunk screw in the splined portion of the hub gives access to the split pin which locks hub nut, this split pin can then be removed easily and replaced through the hole in the hub.

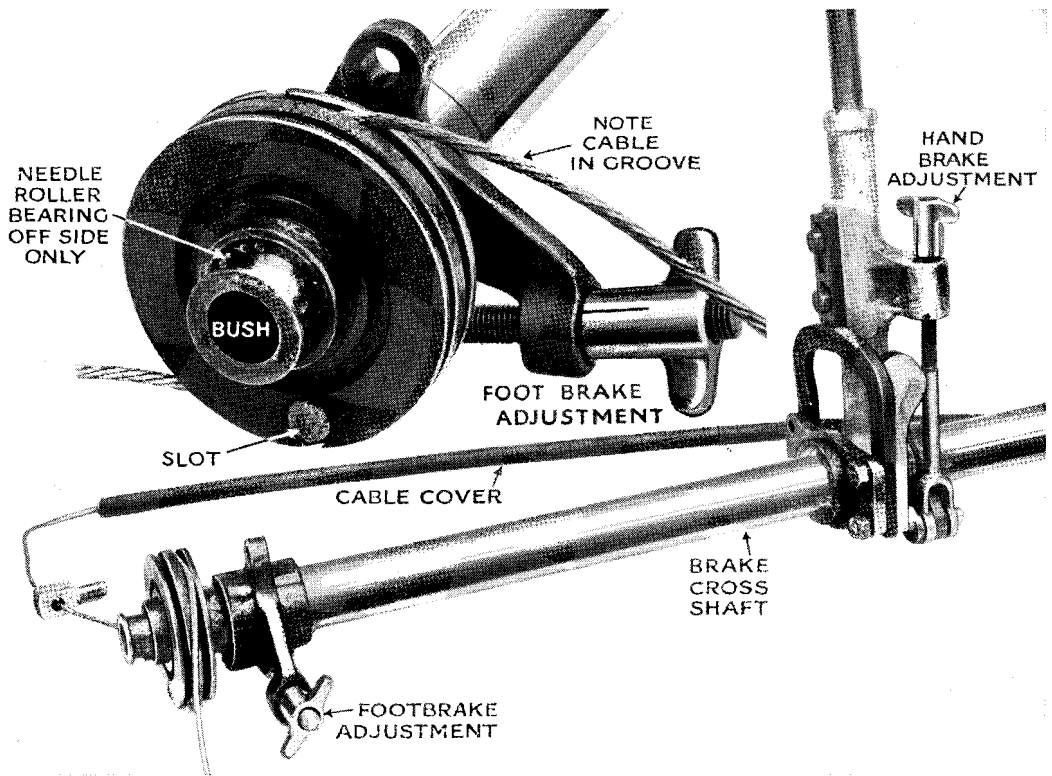
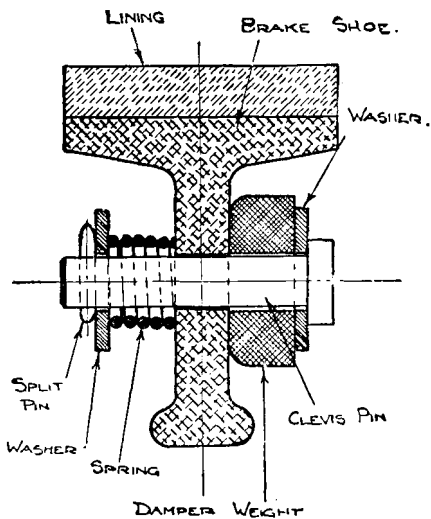

Illustration No. 12.

Brake Anti-squeak Device.—The brake-shoes are fitted with an anti-squeak device, which consists of lead alloy blocks fitted into the channel section of the brake-shoes and held in position by means of clevis pins and little coil springs. When vibrations take place in the brake-drum, they are communicated to the brake-shoes and the shoes vibrate ; the lead weights, however, are in effect " left behind " by the vibrating shoes and energy is wasted in friction between the weights and the shoes. The conditions under which the weights are mounted can in practice be made such that they can always waste more energy than the squeaking forces can generate and the squeak is prevented.



Illustrations Nos. 13 and 14.

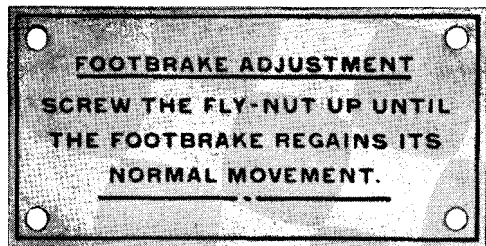

Illustration of foot-brake adjustment plate. This plate is fitted on the trap-door in the floor-board in front of the driver's seat.

(Left) a sectional sketch, showing a brakeshoe with the anti-squeak device attached.

SECTION C

ENGINE



General Description
Engine Mounting
Engine Dismantling
Cylinder Head Removal
Grinding-in Valves
Reassembling Valves
Tappet Adjustment
Timing Dismantling
Cooling
Water Pump
Engine Lubrication

General description of the Engine.—In order that the owner may become familiar with all the details of the power unit, illustrations have been prepared showing both sides of the complete engine unit suitably lettered to indicate the various parts. More detailed instruction will subsequently be given concerning distributor and dynamo. Illustration No. 16 shows the sump or oil container of the engine and its drain plug, which consists of a brass nut having a square hole. A special tool is provided in the kit to remove this drain plug. It will be seen in Illustration No. 17 that there are return oil feed pipes from the front and rear end of the cylinder head. The tap on the cylinder block for emptying the water jacket when it is desired to empty the entire water system can be seen also. This tap should always be used in frosty weather when draining out the water.

The near-side of the engine illustration shows the front extension on the extreme left of the illustration which acts for the dual purpose of starting handle bracket and radiator support as well as front engine bearer.

The water inlet pipe to the cylinder block is also visible.

The front end of the crankshaft is fitted with gearing which in turn drives the oil pump. The oil is sucked up by the pump from the sump and delivered to the oil filter, where it passes through a specially prepared inner body, to be delivered to the main bearings and the overhead valves, camshaft and rockers. A passage from the filter is fitted with a tap-controlled union to which the pipe to the oil gauge is attached. The pipes in which the oil is delivered to the front main bearing and the overhead valve gear will be seen, as well as the details of the oil filter connections, in Illustration No. 16.

The oil feed pipe which serves to feed the overhead valve gear with oil is attached to the cylinder head and must always be removed very carefully whenever the head is lifted, because behind the nut and flange there is a detachable metering or restriction pin, which controls the amount of oil that passes through the orifice.

If the pin is removed (it simply pulls out) it will be noted that it has a flat machined on it which meters the amount of oil passing to the valve gear. The oil pressure to the overhead gear is restricted by means of the metering pin to approximately 5 lb. per square inch.

It will be noticed that the dynamo is placed vertically in front of the engine and the armature shaft is utilised to drive the overhead valve gear. The distributor is seen on the right-hand side of the Illustration No. 17 and the three oil drain pipes which convey surplus oil back to the sump.

Illustration No. 16 shows the water and exhaust manifolds; copper and asbestos washers are fitted between them and the cylinder head. If ever the manifolds are removed, the washers should be inspected and cleaned. The nuts holding the manifolds to the studs should be gradually tightened to get a uniform pressure and prevent any possible chance of leakage through distortion.

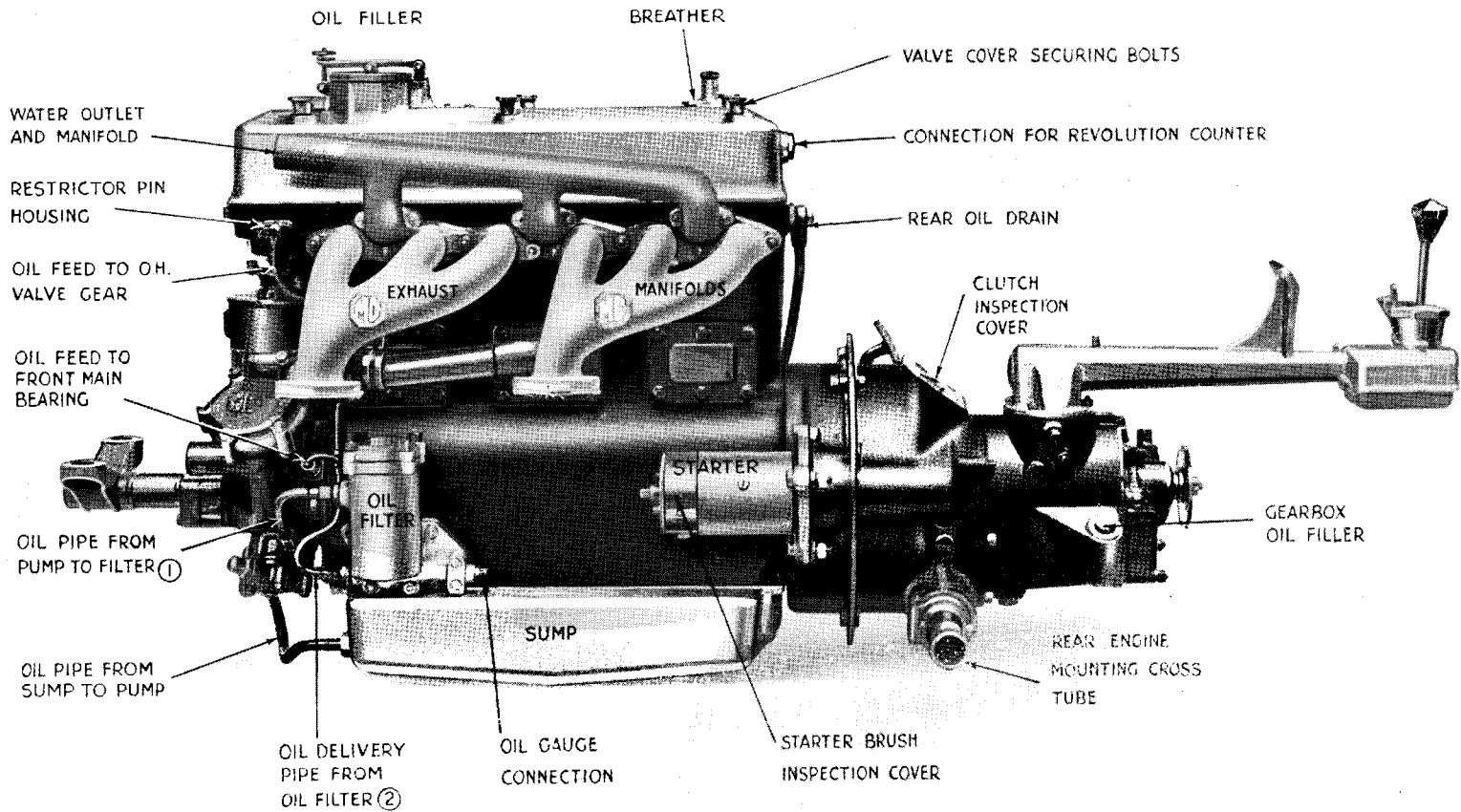

Illustration No. 16.—NEAR-SIDE ENGINE VIEW.

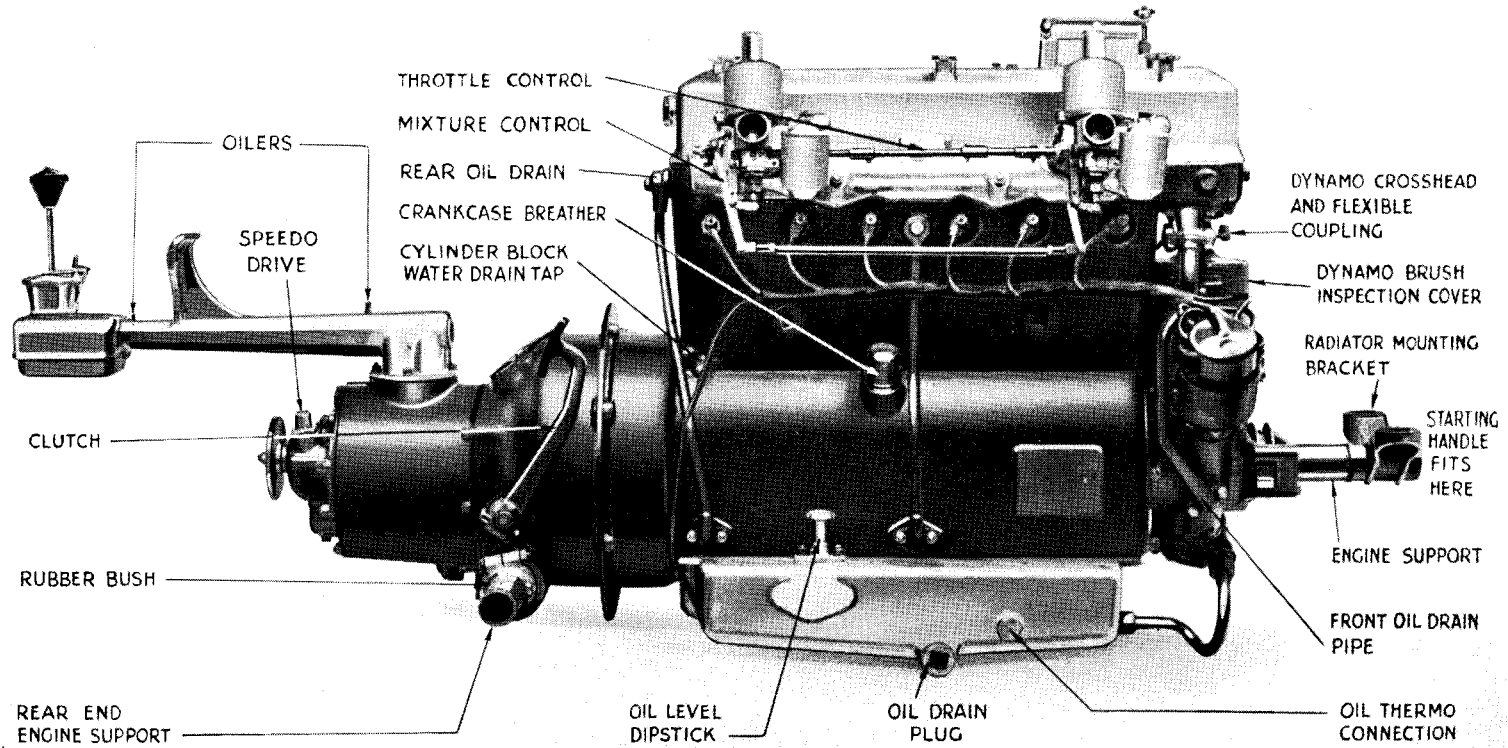

Illustration No. 17.—OFF-SIDE VIEW OF ENGINE.

Engine Mounting.—It will be seen in Illustration No. 35 that a steel tube passes through the clutch housing and is supported in two rubber-lined bushes, one either side, securing the engine unit in the frame at the rear end. The front end mounting, however, is entirely different.

The front engine bearer passes through the front cross member, a bush being interposed to afford a certain amount of resiliency to the mounting, and isolate the engine from road shocks. Reference back to Illustration No. 17 shows the means whereby the radiator is attached to an extension of the front engine bearer. This illustration is particularly instructive in case it is necessary at any time to remove the radiator. The radiator proper is mounted on the front engine extension by means of two studs and nuts and interposed fibre washers.

Engine Dismantling.—The principal external components of the engine having been illustrated, it is now proposed to describe the construction of the engine and the method of dismantling.

Before dismantling the engine it will be necessary, first of all, to drain the water system by opening the tap at the bottom of the radiator and the small tap on the cylinder block.

Remove the bonnet and valve cover altogether.

Detach the cables from the sparking plugs. These are all different lengths so there is no fear of confusion when reassembling.

Remove the carburetters after first uncoupling the petrol pipes from the float-chambers, the throttle control, and the mixture controls, being careful not to upset the setting, otherwise they will need re-synchronising. Do not separate them ; there is no need, but they will have to be taken off the manifold.

Release the water manifold by undoing the attachment clips ; then disconnect the exhaust pipe and manifolds.

The first feature in dismantling is obviously the cylinder head. This comprises the dismantling of the valve gear, and afterwards the grinding-in of the valves. It is necessary, therefore, to be acquainted with the relationship of the cylinder head to the cylinder block, and the method of driving the camshaft.

The first thing that should be borne in mind is that considerable care has been exercised in the design of the engine to render the operation of valve timing as simple as possible. It must be taken for granted that the drive from the crankshaft through the dynamo is correct, and it follows, therefore, that when the dynamo is in a certain position there is a definite relationship between the arms of the coupling on the top of the dynamo and the position of the pistons in the cylinders.

When the cross head of the dynamo coupling is in the position shown in Illustration No. 18, that is to say with the bolt through the coupling attached to the dynamo towards the front of the car, and the inlet and exhaust valves of No. 1 cylinder are closed, then No. 1 piston is on top dead centre of the firing stroke.

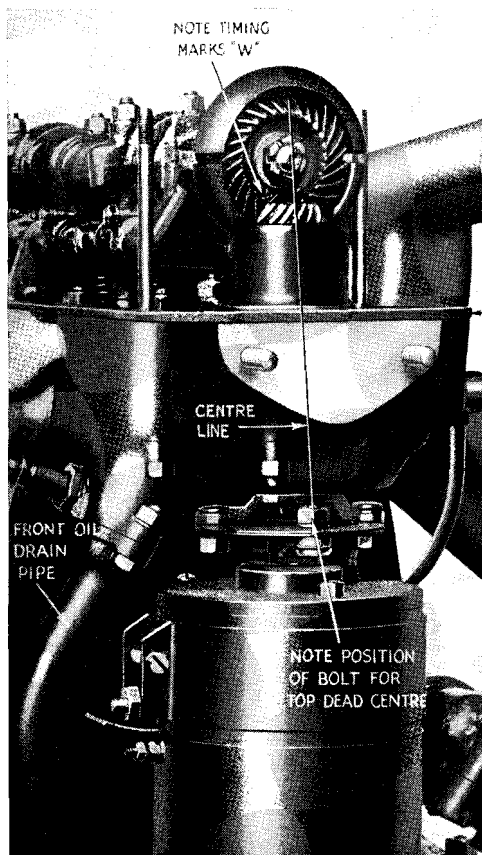

Engine Firing Order : 1, 4, 2, 6, 3, 5.

Illustration No. 18.—Showing the position of dynamo coupling and camshaft bevel gears for T.D.C. No. 1.

The cross head coupling attached to the dynamo is connected to the coupling driving the vertical spindle by means of laminated steel discs, and when the overhead valve camshaft cover is removed it will be seen that there is a mark on the driving bevel gear wheel which meshes with the camshaft gear wheel, and if ever the camshaft is removed, provided nothing else has been disturbed, it is necessary only to see that the distributor rotor is pointing to No. 1 plug lead, when these marks only have to coincide for the timing to be correct.

It also follows that if one wants to find top dead centre to check the ignition, or for any other purpose, it can be found by turning the dynamo coupling, as shown in Illustration No. 18.

The form of coupling employed permits the cylinder head being removed without disturbing the timing in any way.

It is only necessary to undo two bolts to disengage the coupling between the dynamo and the cylinder head.

VALVE TIMING DIAGRAM

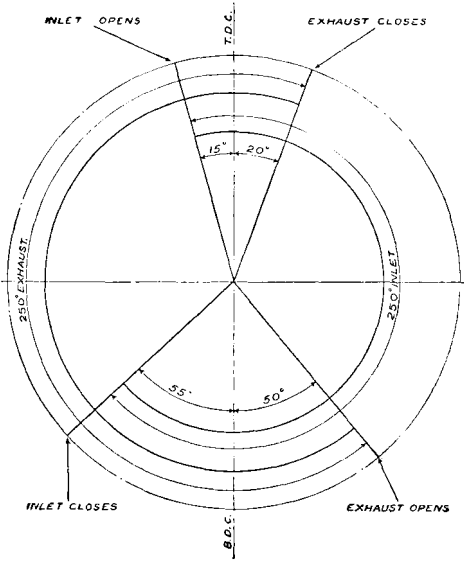

INLET OPENS 15° before T.D.C.
INLET CLOSES 55° after B.D.C.

EXHAUST OPENS 50° before B.D.C.
EXHAUST CLOSES 20° after T.D.C.

Illustration No. 19.

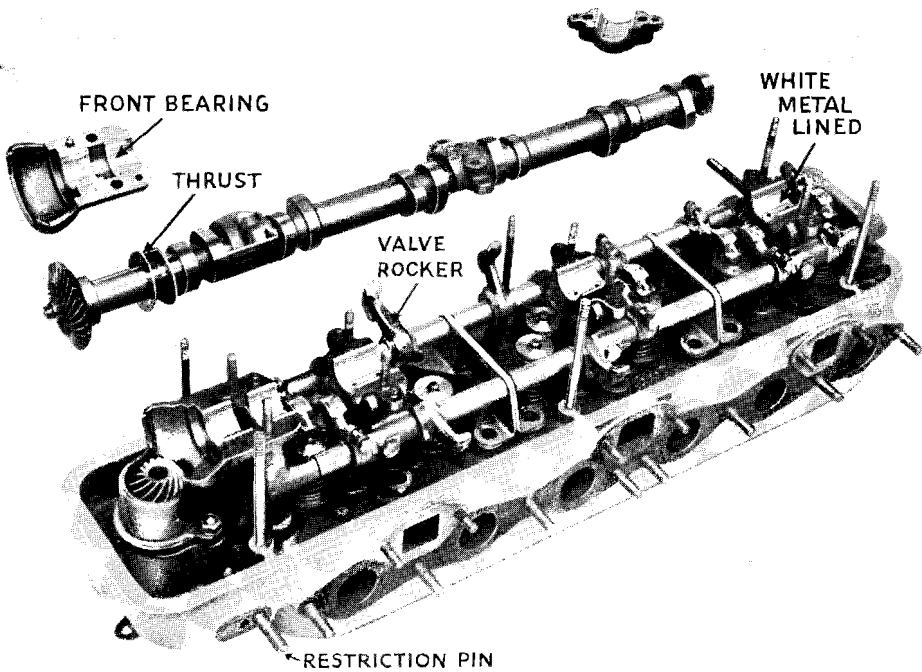

Illustration No. 20.—Various items of the overhead valve gear shown in dismantled form referred to in text.

Cylinder Head Removal.—Whenever the cylinder head is removed it is obvious that the oil delivery pipe and return pipes will have to be disconnected and the two nuts securing the bracket between the engine and the radiator removed altogether. The cylinder head holding-down bolts should be slackened off in the order shown in Illustration No. 21. A $\frac{3}{8}$ in. special ring spanner is required, and one of these is included in the tool kit. A copper and asbestos gasket is fitted between the cylinder head and the cylinder block, and if ordinary care is employed there is no reason why this should be damaged in removal. The joint between the cylinder head and the block may have become tight, due to the presence of carbon and jointing compound. It will be noticed that there are notches in the gasket on either side and these are to allow a screwdriver or similar instrument to be inserted for the purpose of easing the head without damaging the gasket. Even so, a certain amount of care should be exercised.

After the cylinder head has been removed, stuff the open ends of the cylinders with clean rag to prevent particles of carbon, etc., from getting on to the cylinder walls. The cylinder head can then be dealt with. First remove the camshaft, taking care to ease off the nuts evenly, noting the position of the Belleville and thrust washers. It will be noted that each valve is numbered in relation to the number on the face of the cylinder head. The valve springs are secured by means of split cotters, and to remove each valve the cylinder head should be placed on the bench, combustion chamber side downwards, with a wood block or suitable packing piece which fits in the combustion space. By depressing the spring from above the two halves of the cotter can be removed and the spring and its cap will then lift away from the valve, which can be withdrawn from below.

Grinding-in the Valves.—Examination of the valves will show that the edges of their mushroom-like heads are bevelled off at an angle to correspond with the similar bevelled edges of the valve ports in the cylinder head and thus provide a gastight joint when they are in contact. Obviously, gastightness is not attained if these bevelled edges are dirty or "pitted," and in order that they make perfect contact over the whole of their surfaces it is necessary to grind them in. When grinding-in the valves the utmost care should be taken to see that they are inserted into the correct port, as previously mentioned.

The grinding-in process consists in coating the bevelled face of the valve with a small quantity of valve-grinding paste—applied on the end of a match-stick—re-inserting the valve in its guide and partially rotating it backwards and forwards on its seating by means of a screwdriver. Here we come to the secret of good valve grinding. The valve should be raised from its seating every few reciprocations and given a half turn in order that the grinding compound may spread itself evenly over the whole surface. If this is not done there is the possibility that minute circular grooves will be cut into the face of both the valve and its seating, which will absolutely prevent one from obtaining a good gastight fit. Probably the most convenient way of carrying out this periodical lifting is to obtain a light coil spring (similar to the valve spring but much lighter), and insert it into the valve port beneath the valve head. When pressure is released on the screwdriver the valve will pop up, when it can easily be rotated into a fresh position.

It is not necessary to continue grinding the valves once the faces of both valve and seating have assumed a clean, even, matt-surfaced appearance. A polished surface must not be expected and is quite unnecessary. If the engine has been run for a long period without being decarbonised, the valve may be badly "pitted"—that is to say, it will have a number of small black spots or depressions on its face. Should these depressions be at all excessive or deep, it is best to have the valve face trued up on a special machine to an angle of 30°. In extreme cases it may be necessary to treat the valve seats in a similar way. This will prevent needless grinding away of the valve seating in the cylinder head—a matter of importance, as it cannot be renewed. Any valves which are distorted should immediately be replaced by new ones. To attempt to grind them in will only produce extensive damage to the seating.

After each valve is ground in it should be withdrawn and carefully washed in petrol, and, what is equally important, the valve seating and the surrounding valve port should also thoroughly be cleaned with a rag moistened with petrol. Do not wash out the valve ports with petrol or paraffin or some of the grinding compound will find its way into the valve guides or other working parts, and it is of the utmost importance that it should be prevented from finding its way on to any of the working surfaces of the engine, where extensive damage may be done.

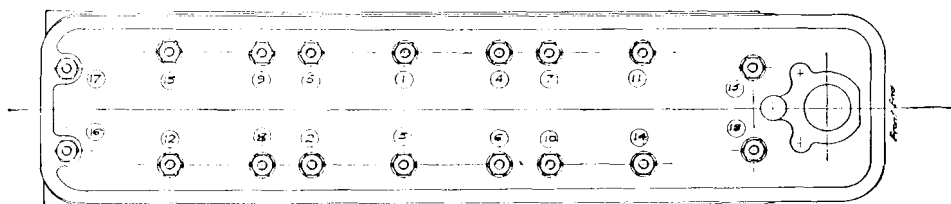

Illustration No. 21.—Showing the rotation of slackening off and bolting down the cylinder head.

Reassembling the Valves.—When you have satisfied yourself that all trace of the grinding compound has been removed, the valves may be reassembled. Care should again be taken to see that they are in their correct ports. Reassembly of the valve is not a difficult matter. After inserting the valve in its guide and resting its head on the wood packing block, the valve spring may be placed in position with the valve spring cap resting on top of it. Engage a tool on the cap and depress the spring so as to expose very nearly the whole of the groove in the upper end of the valve stem. Insert the two conical cotters into the groove in the valve stem (small ends downwards, of course) and gradually release the spring. Make sure that the cotters are properly engaging in their grooves before dealing with the next valve.

The camshaft is mounted in white-metal bearings and oil is introduced into the bearings along each of the rocker-shafts, as well as supplying the drilled rockers. The surplus oil drains back into the sump. It will be noticed that some of the cylinder head holding-down bolts pass through brackets that support the rocker-shafts in position.

A number of washers will be seen on the camshaft, consisting of steel discs and spring steel washers. These fit on the front side of the front bearing next to the bevelled gear, and take the thrust of the drive of the shaft.

Before refitting the cylinder head make quite sure that the holes in the gasket register correctly with those on the cylinder block; a smear of grease on both sides of the gasket assists in making a good joint.

The complete camshaft drive assembly shown in Illustration No. 23 is secured to the cylinder head by four studs and nuts, and in order to ensure correct meshing of the driving pinion with the camshaft gear wheel a number of shims are employed between the face of the cylinder head extension and the oil drain housing. These are in point of fact a Factory fitting, but care should be exercised, if ever the unit is removed, to see that the shims are neither damaged nor omitted when refitting. The caption beneath the illustration suffices to describe it.

Tappet Adjustment.—The owner will probably be aware that there is a necessity to have a definite clearance between the cam and the valve rocker, the various parts are distinctly marked in Illustration No. 22. It is of course important to see that the valve is properly seating when any adjustment is attempted, and this can easily be seen by the position of the cam in relation to the rocker. There is a single camshaft operating both the inlet and the exhaust valves. These are easily distinguished, from the fact that all the exhaust valves are on the *near-side* of the engine and the inlet valves on the *off-side* of the engine. The valve rockers are attached to separate shafts at their outer extremity, and are provided with eccentric bushes. The opposite extremity of the rocker is wedge shaped, so that if the nut which forms part of the eccentric bush is rotated, the wedge end of the rocker will either advance or recede from beneath the cam, and present a thicker or thinner section to the face of the cam when this rotates. The eccentric bush is provided with a pinch bolt shown in Illustration No. 22; a spanner ($\frac{1}{8}$ in. Whitworth) is needed to slack off the pinch bolt.

It is possible for a person not acquainted with the engine to set the rockers in various wrong positions, which will cause considerable variation of timing of the corresponding valve.

The correct method which prevents mistakes is as follows :—

1. The clearance is measured between the rocker and the back of the cam and should be .006 in. inlet and .008 in. exhaust, tested by feeler gauge, when the engine is at its normal running temperature.

2. The clearance must always be decreased by pressing the handle of the spanner downwards.

3. If pressing the spanner down increases the clearance the eccentric has been turned too far, in which case continue turning down until the clearance decreases. Then adjust as described in No. 2.

When adjusting the rockers, it should be remembered that the valve gear is designed to give the correct valve timing when the cam and rocker is in the position shown in Illustration No. 22 with a clearance of .006 in. inlet and .008 in. exhaust measured between the top of the rocker and the cam. It may be found after the valves have been ground in that the clearance has been taken up, and although the point can be disregarded within small limits, it is advised that in order to get best results from the engine the valve lengths should be checked up, and if necessary shortened after they have been ground in once or twice, by an authorised M.G. Agent.

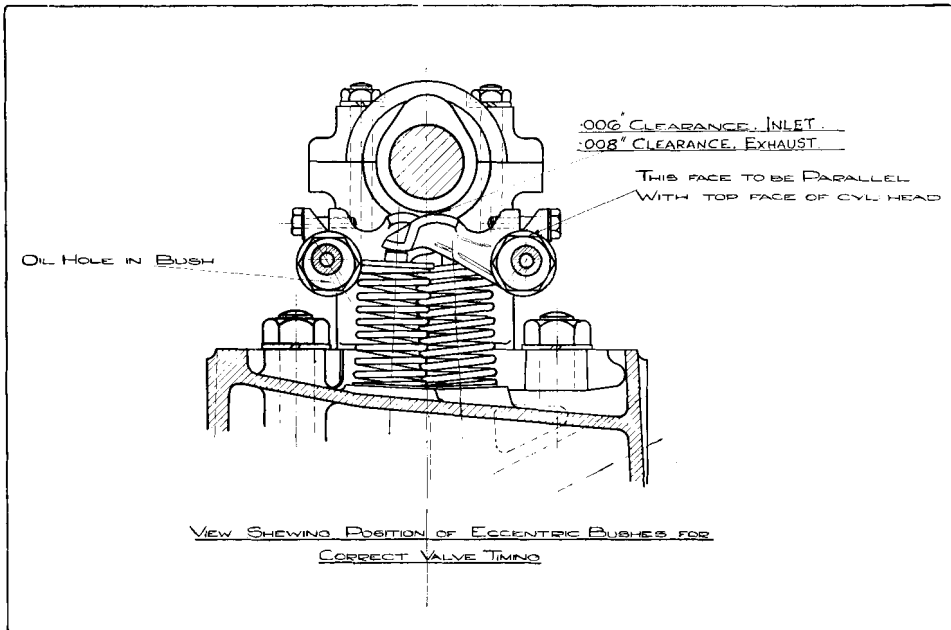

Illustration No. 22

Valve Guides will need renewing periodically, the oiling of plugs is an indication. This should not be undertaken by the owner, as the guides need very accurate fitting, and we recommend that it be left to an authorised M.G. repairer, who will at the same time be able to check the valve timing, as advised in the instructions on page 28.

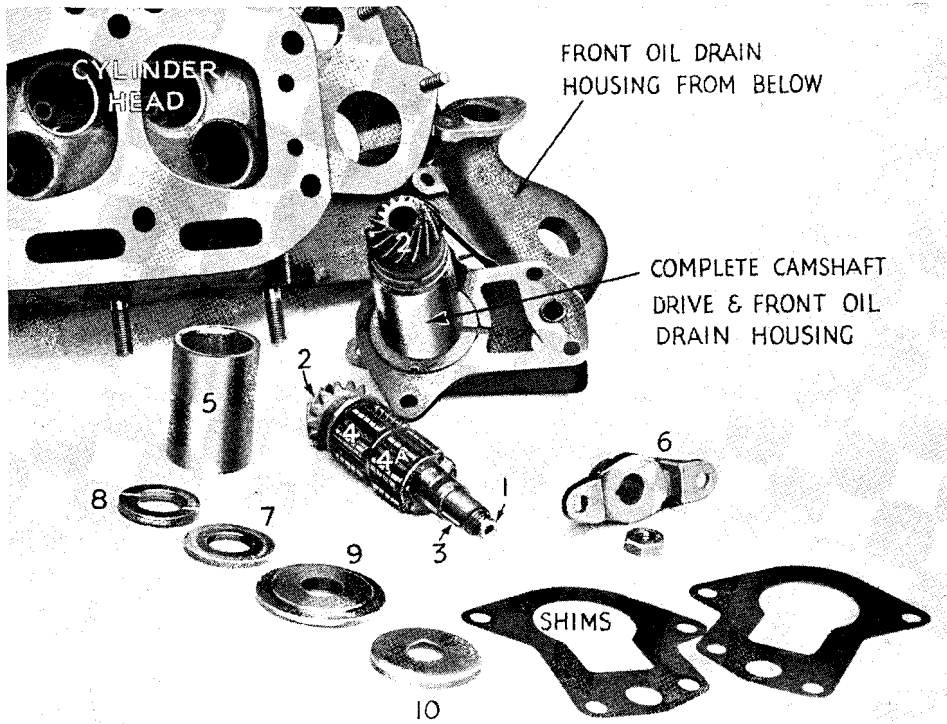

Illustration No. 23.—View of the underneath side of the cylinder head, with complete camshaft drive removed. A separate unit has been dismantled, the parts being as follows:—

- | | |
|---------------------------------------|---|
| 1. Camshaft driving shaft. | 6. Universal joint fork for bevel pinion. |
| 2. Camshaft driving bevel pinion. | 7. Bevel pinion washer. |
| 3. Camshaft driving bevel pinion key. | 8. Bevel pinion thrust washer. |
| 4. Hyatt roller bearing. | 9. Bearing retainer plate. |
| 4a. Hyatt roller bearing. | 10. Bevel pinion oil thrower. |
| 5. Bevel pinion bearing sleeve. | |

Timing Dismantling.—The following operations will deal with a number of parts, such as oil pump, distributor, and dismantling of timing gears. All the various parts are so co-related in the case of the M.G. engine that the description may appear to be somewhat disjointed, but it will be found that the illustrations will materially assist and are, in fact, more informative than any amount of text.

Take Illustration No. 24. This shows the sump and the suction filter and the baffles which prevent the oil from surging, also the pipe line through which the oil passes on its way from the sump to the pump.

The suction filter consists of a tube surrounded by a fine gauze mesh through which the oil in the sump has to pass prior to being drawn into the oil pump. The filter should be removed from time to time and thoroughly washed in petrol. When replacing it, make sure that the fibre washer between the nut and the sump is not damaged. It is also necessary to see that the short snail-shaped pipe between the suction filter and the oil pump is properly tightened up, because a very small leak at this point would be fatal to the oil circulation.

Reference to Illustration No. 27 shows the pump actually removed. The pump is attached by means of five studs. The upper end of the pump spindle is castellated and registers inside the lower extension of the distributor drive, or internal drive, and driven by the pinion which engages with the worm on the crankshaft.

To remove the distributor it is only necessary to take out the set screw and withdraw it from the internal drive. The slots in the drive are "off centre," so the distributor will go back in two ways only in relation to the engine, one of which is right. The correct position can be determined by the position of the dynamo coupling in relation to T.D.C. of No. 1 cylinder when both exhaust and inlet valves are closed (i.e. No. 1 piston at the top of its compression stroke), then if the rotor on the distributor is pointing to No. 1 segment on the cover the distributor will go back correctly.

It may be necessary at some time to remove the dynamo. This is a comparatively simple matter if reference is made to Illustration No. 25. The front end extension of the crankshaft is fitted with two gears, a spiral bevel and a worm. The spiral bevel drives the dynamo, and here again we find the necessity for correctly meshing gears, which is taken care of by a number of interposed thin metal shims. The dynamo gear is attached to the spindle by means of a bolt and tab washer, the gear being held in position on the shaft by means of a key. The gears are suitably marked for re-meshing, but the dynamo cannot be put back wrongly if No. 1 piston is put on top dead centre and the coupling on the top of the dynamo placed so that it points accurately fore and aft, as indicated in Illustration No. 18. The object of the shims is to allow the gears being correctly meshed when assembled.

Cooling.—Water circulation is by pump driven off the crankshaft. Keep the radiator filled with clean water to about 1 in. from the top. Rain water should always be used in preference to tap water as it does not "fur" the interior of the water ways to such a great extent. The whole system should be flushed out every 5000 miles; if possible place a hose in the filler orifice and open the tap at the bottom of the radiator and run the water through the system for about fifteen minutes to flush it out thoroughly.

In frosty weather the radiator should be emptied if the car is left standing long enough for the water to freeze, unless of course "Anti-freeze" is being used. Otherwise considerable damage to the radiator and cylinder casting may result.

Alcohol or glycerine may be used as anti-freezing mixtures, the latter is preferable as it is not subject to evaporation, as is the case with alcohol. Glycerine must be diluted before being poured into the radiator.

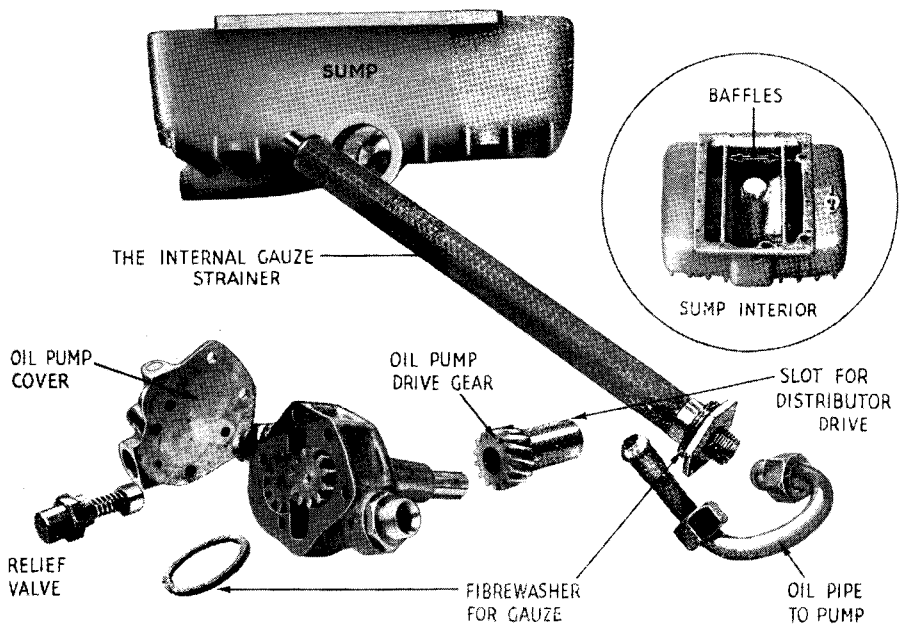

Illustration No. 24.—Details of the sump and internal gauze, also the oil pump and its connection to the sump. (See also Illustration No. 27.)

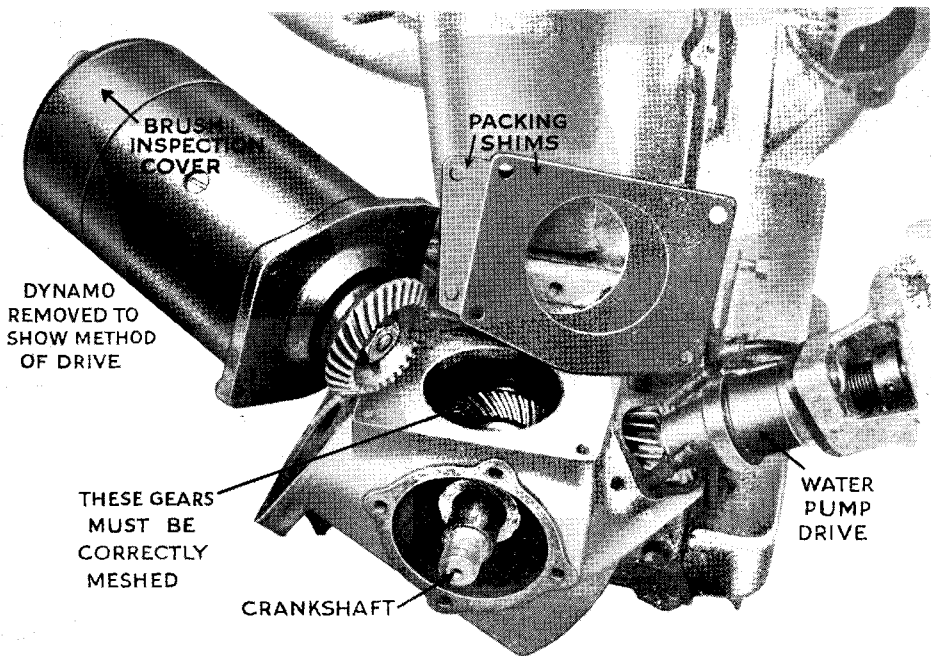

Illustration No. 25.—This shows the manner in which the dynamo is driven. In order to correctly mesh the drive gears it will be noted that packing shims are interposed between the dynamo body and the timing case. The water pump, if fitted, is driven by a separate gear in front of the bevel which drives the dynamo.

The following table shows the proportions of water and "anti-freeze" mixture :

Alcohol or glycerine % by volume	% Water by volume	Minimum temperature Mixture withstands	
		Degrees F.	Degrees C.
20%	80%	+13°	-10°
30%	70%	-3°	-18°
40%	60%	-20°	-34°

Normal running temperature of the water should be 85/95°C. in the header tank. In Winter it is sometimes advisable to blank off a portion of the bottom of the radiator so that this temperature is attained, about a third of film block is the usual amount. Rug up the radiator when the car is left standing in cold weather.

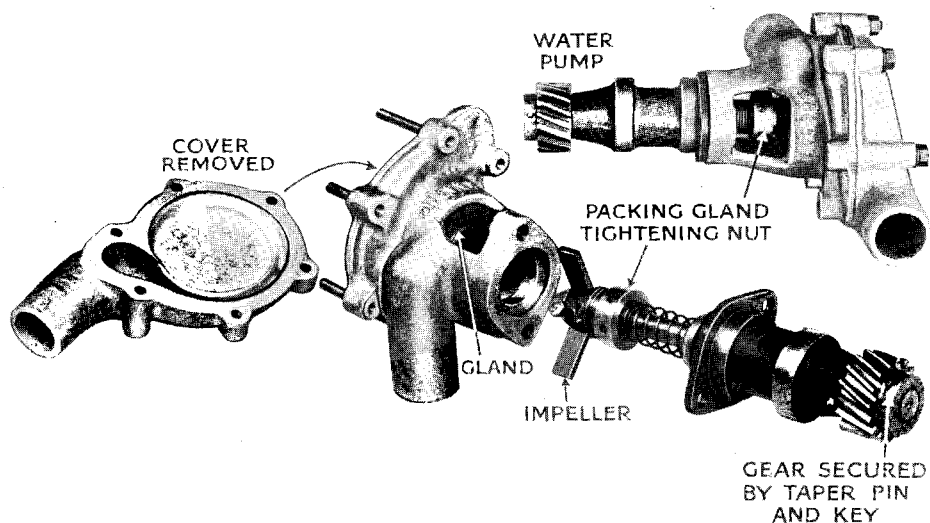

Illustration No. 26.—View of the water pump completely dismantled. The principal point of interest to the user is the packing gland tightening nut. The gland needs no lubrication and should only be tightened sufficiently to prevent leaks.

Water Pump.—Illustration No. 26 shows the complete water pump after removal from the engine, and below this the pump will be seen dismantled. The principal point of which the owner has to take care is the packing gland adjustment. This consists of a brass bush screwed at one end to register inside the pump body and hold the gland (consisting of special pump packing) in position that will prevent water creeping along the pump spindle and leaking. The packing gland nut can be tightened by inserting a small piece of rod in the holes drilled in the nut and using the side of the pump body as a fulcrum. Care should be taken not to tighten the nut too much.

In order to remove the pump from the engine it is necessary to unscrew the two nuts that hold it in position, and after the removal of the rubber hose connections it can be withdrawn by giving it a gentle pull. Care must be exercised, however, in reinstating it to see that the gears mesh before any pressure is put on the pump in replacing it. There are three small items which really only concern the Repair Shop. They relate to the removal of the gear wheels from the crankshaft and the front end housing of the base chamber. After the dynamo has been removed it is possible to withdraw the worm wheel from the crankshaft by levering it off with two screwdrivers (they will have to be fairly long ones), through the dynamo housing. It is a parallel fit on the crankshaft and is held in position by a key.

Crankshaft.—Illustration No. 30 shows the crankshaft, which runs in four main bearings, the front and rear bearings being white-metal lined bushes and the two centre bearings being of white metal, direct in split steel housings. Owing to the size of the webs of the crankshaft it is necessary to employ split housings to accommodate the centre main bearings and to register this in the barrel type crankcase. These housings are held in position by long bolts which pass through them, and which are prevented from turning by the use of tab washers.

Opposite the oil duct on the taper at the rear end of the crankshaft there is a key for the purpose of locating the flywheel flange on the crankshaft. This flange has a hole in it on one side and a keyway cut on the inside. The external extension of the flange fits inside the rear main bearing and is secured to the tapered end of the crankshaft by means of the key, and is locked in position by a nut which can be seen on the end of the crankshaft in Illustration No. 30.

Connecting Rods and Pistons.—Illustration No. 29 shows the type of connecting rod employed. The pistons are of aluminium alloy fitted with three rings (the lower one being an oil control ring). The gudgeon pin is free to rotate in the piston boss and the small-end bearing of the connecting rod. Duralumin end caps are pressed into the gudgeon pins so that these can contact with the cylinder walls without in any way damaging them. It is essential that the radius of these pads should not be altered in any way. White metal is cast direct into the connecting rods for the big-end bearings, and it will be noticed that the bottom cap is of generous proportions and is held in position by means of two bolts. The heads of the big-end bearing bolts are so formed that they register with the connecting rod and are thus prevented from turning round.

The cap or connecting rod at the big-end must not be filed to take up the clearance caused by wear, as it is impossible to re-metal bearings which have been reduced in this way. If new big-ends are required, the existing rods should be changed for a set of re-metalled service ones.

Engine Lubrication.—The actual lubrication of the engine is very simple, a number of points, however, need periodic attention.

The oil filter is shown removed in Illustration No. 28, with the connections marked thereon. In point of fact the hole that can be seen on the removed oil filter marked "oil feed" couples up with a hole drilled in the crankcase, so that the oil that is forced by the pump into the oil filter is cleansed and is delivered internally to the centre and rear main bearings. A view of the oil filter in dismantled form is shown on page 34. The oil feed passes through the union No. 2 to deliver oil by means of an external pipe to the front main bearing and the overhead valve gear.

The pump is of the gear type, fitted with a cover-plate and having a by-pass relief valve incorporated in the body of the pump. The relief valve, as can be seen in Illustration No. 28, consists of a cover which encloses a spring and maintains the small piston up against a seating in the pump body until such time as the force of the oil through pressure forces the piston off its seating. Whenever this occurs the release of excess oil will maintain the oil pressure at a point pre-determined

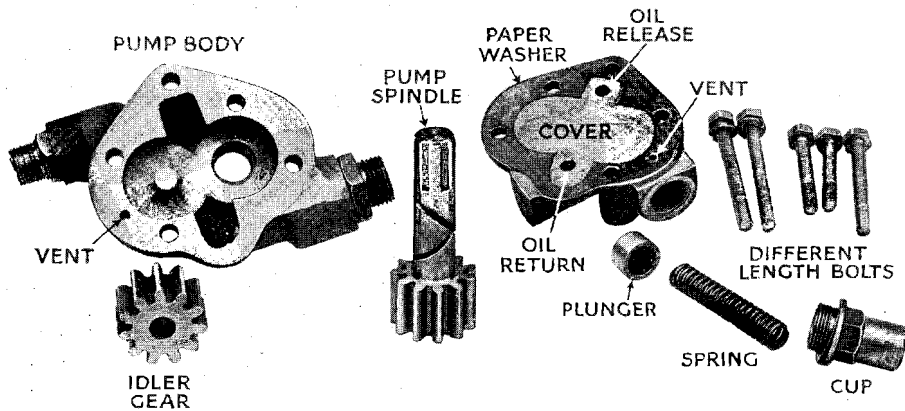

Illustration No. 27.—The components of the oil pump, which is of the gear type. The pump spindle gear engages with the idler gear.

The principal part of the pump to examine is the relief valve, which consists of a plunger, spring and hollow cap nut. When the oil pressure registers a pre-determined limit, the spring is compressed and allows the plunger to uncover a passage which will cause the pressure of the pump to drop. There is no adjustment to the amount of pressure; this is determined at the Factory, and is governed by a spring.

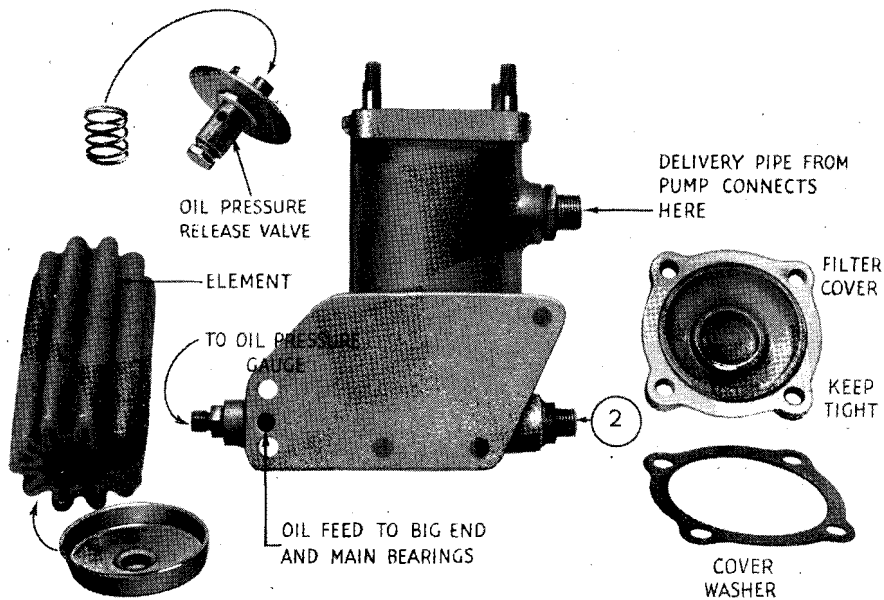

Illustration No. 28.—The Tecalemit oil filter, referred to on page 33, shown in complete form and also dismantled. The various figures serve to indicate the position of the various components to assist assembly when fitting a new element.

by the makers, i.e. approximately 60 lb. per square inch, dependent upon the resistance of the spring. It is obviously possible to increase the tension of the spring by introducing washers in the cap, or obtaining a stronger spring, but no such alterations should be effected without first obtaining the advice from the M.G. Service Dept.

Oil that is forced to the main bearings finds its way under pressure to the big-end bearings through holes drilled in the crankshaft, whence in the usual course it is thrown out by centrifugal force, finding its way upwards to lubricate the pistons and gudgeon pins. The path of the oil can better be followed if the dismantling of the engine is now continued.

Before proceeding with the details of the oil circulation it is as well to explain that in the interior of the sump there are a number of baffles to take care of oil surging, also the suction filter registers in a boss in the centre of the sump.

The front main bearing and overhead valve gear is fed with oil by an external pipe from the filter No. 2 in Illustration No. 28. A restrictor pin (see Illustration No. 16) limits the pressure at which oil is supplied to the head, and the surplus oil drains back to the sump through the oil return pipes. The restrictor pin should not be filed or altered in any way, and when the head is removed it should be taken out so that it is not lost, and when reassembling do not forget to replace it.

The rear main bearing is similarly designed to the front one. This and the centre main bearings are fed from an oil pipe connecting up with a duct in the side of the crankcase fed from the oil filter.

The crankshaft is shown in Illustration No. 30, the main journals being indicated by the letter "M" and the big-end journals indicated by numerals. A close examination of the illustration will show that the shaft is drilled so that oil can pass through the holes in the shaft from the main to the big-end bearings. At the rear end of the crankshaft there is an oval slot with a hole in it, which serves as a duct for the oil to No. 6 big-end bearing.

Oil is fed to the other big-end bearings through ducts in the front and centre main bearings.

Note :—Should the owner have the misfortune to run a bearing—in other words, through insufficient lubrication the bearings become molten—it will be found that part of the white metal will actually run into the oil channel ways and block them. Cases have been known where the bearing has been refitted, and omission to clear the crankshaft has only resulted in the bearing running immediately after reassembly. If ever a bearing runs, it is necessary to see that all the ducts through the crankshaft are cleaned out, and it may even be necessary to remove the blanking plugs in the crankshaft journals and pass drills of correct size through the holes. It may be found, however, that only a small quantity of white metal has run into the oil ways, and if a syringe of thin oil is squirted through these oil ways it is possible to see if they are clear.

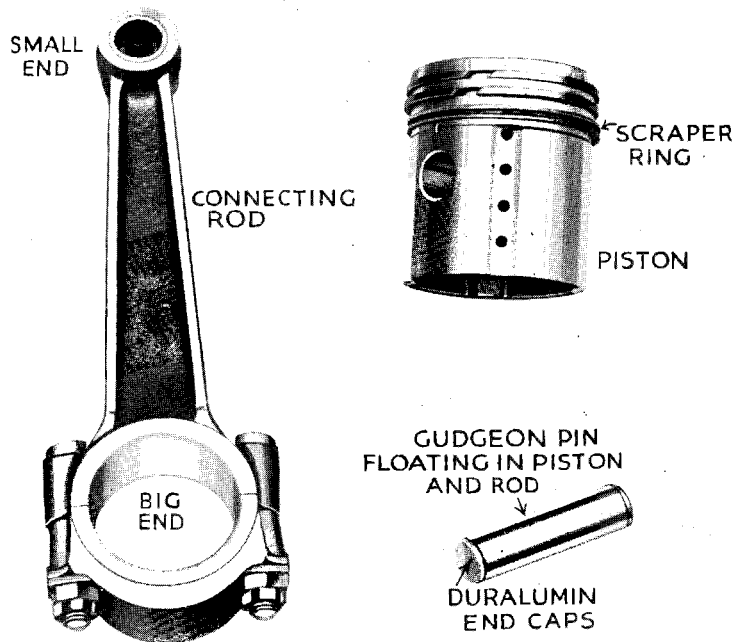

Illustration No. 29.—The gudgeon pin is hardened and ground and is free to float in piston and connecting rod. It is fitted with duralumin end caps to prevent scoring the cylinder walls.

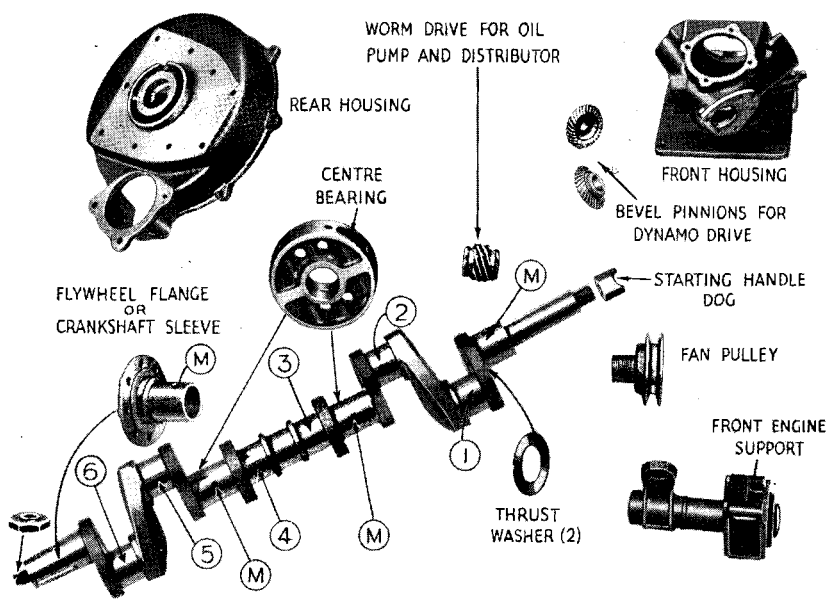

Illustration No. 30.—Various parts of the crankshaft and bearings referred to in the text.

SECTION D

CARBURETTORS

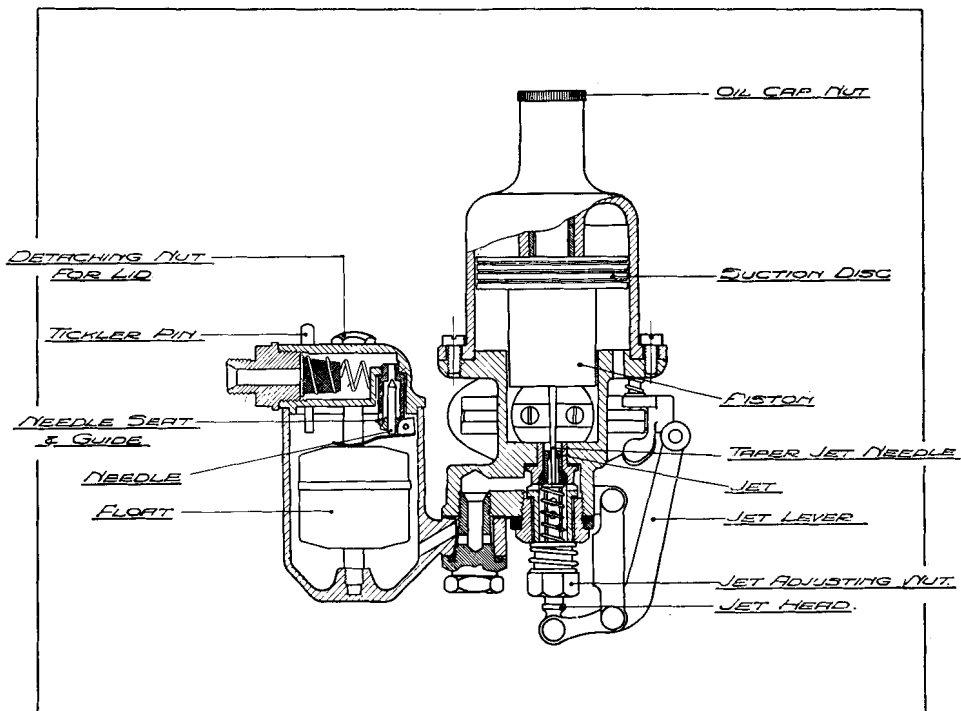

Illustration No. 31.—Sectional view through an S.U. carburetter, showing how the taper needle is locked into a piston which is caused to rise by the suction of the engine and so increase the orifice of the jet, thereby governing the petrol flow. It will be realised by this illustration that the effect of screwing the jet adjusting nut up or down has actually no effect on the jet itself ; it is simply an abutment for the jet head which is controlled by the jet lever. The two screws holding the suction disc outer chamber in position should be removed from time to time, and the suction disc and piston carefully cleaned with a dry rag ; under no circumstances should oil be used on the suction disc. The oil cap on the top of the suction disc chamber simply lubricates the spindle which guides the suction disc during its up and down travel.

The steel adjusting screw on the outside of the carburetter is only intended for slow-running adjustment and does not alter the mixture.

Carburetter.—Separate instruction concerning the S.U. Carburetter is provided with the car, but the following will be of additional assistance.

Since the two carburetters are identical, it is necessary except in the case of synchronising to describe the construction and maintenance of one instrument only.

A little machine oil should be injected into the dashpot or suction chamber brass cover screw every thousand miles, to lubricate the piston guide rod ; three drops of machine or bicycle oil are advised for this purpose.

Under no circumstances should the body of the piston be lubricated.

By inserting a finger through the air inlet to the carburetter, the piston can be lifted inside the body of the carburetter, and should rise and fall freely.

Should it be necessary to adjust the jet position to afford a richer mixture, the jet control nut should be unscrewed.

By screwing the jet adjusting nut upwards and at the same time moving the jet head to meet it, the mixture is weakened and the petrol consumption can be cut down if the owner is satisfied with a lesser degree of acceleration and speed, and sometimes in hot weather general all-round better carburation can be obtained by thus cutting down the petrol supply. Screwing up too much may cause popping through too weak a mixture. Too weak a mixture may also cause burning of the valves due to overheating.

The use of the strangler, or, as it is correctly called, the jet control, is intended only for starting when the engine is cold, and should be employed as little as possible. The effect of using the jet control is to enrich the mixture when starting. If it is left in operation longer than is necessary the cylinder walls will be bathed with surplus petrol, which will soon have a damaging effect on the pistons and other parts of the engine as well.

Reference to the illustration of the carburetter shows the jet control lever in position. The jet adjustment nut is in point of fact only a stop against which the jet head rests when the jet control lever is in the normal running position (pushed in), so that it stands to reason that if any adjustment of the jet has to be effected, this has to be carried out on each carburetter separately. The rod coupling the two jet control levers should be removed before any jet adjustment is made, and before replacing this it should be rendered of suitable length by screwing up or unscrewing one of the forked ends, so that after finally replacing, both jet heads abut simultaneously against their stop nuts.

Periodically clean the suction disc, suction chamber and guide. To remove the suction chamber the two screws that hold it in position should be removed. Extreme care should be exercised in removing the piston, so as not to damage the taper jet needle in any way. Mark the suction chamber before removal and replace it the same way as originally fitted. Do not change the suction chambers from one carburetter to another.

Sources of Trouble.—There are only four troubles which may affect the functioning of the S.U. carburetters.

1. The piston may be sticking, due to dirt on the suction disc or piston or due to a bent needle.
2. There may be dirt or water in the carburetter.
3. The float mechanism may have become deranged, and the carburetter is in consequence flooding.
4. The carburetters may require synchronising.

Piston Sticking.—The moving element consists of the piston proper, forming the choke, into which is inserted the hardened and ground piston rod working in a bearing in the suction chamber ; the suction disc formed on the upper part of the piston ; and a tapered needle inserted in the piston regulating the jet opening. If the piston is sticking this can easily be ascertained by inserting a finger in the air intake and raising the piston. The piston should come up quite freely and return to its seat with a click as soon as it is released.

A large percentage of the carburetters returned to the Works for correction have had the jet removed and replaced without being correctly centred. On no account should the jet be tampered with.

It is quite an easy matter to bend the needle if the piston is at any time removed, in which case it will bind on the jet and cause the piston to stick. To ascertain if the needle is bent—providing the jet is not out of centre—remove it from the piston, refit the suction chamber on to the body of the carburetter and see if the piston falls freely. If the needle is bent the only satisfactory remedy is to replace it by a new one.

Float-chamber Flooding.—This is usually obvious from the quantity of petrol flowing over the float-chamber. Flooding is generally caused by foreign matter finding its way on to the seating of the float-chamber needle. It can sometimes be removed by flooding the carburetter with the tickler pin, thus permitting the incoming petrol stream to wash away the particles of grit, otherwise access to the needle is obtained by removing the float-chamber top. To take out the needle it is necessary first of all to take out the pin which holds the needle actuating fork in position. After taking away the fork the needle will drop straight out ; the seating should on no account be ground in.

Synchronisation of Carburetters.—Before attempting to adjust the carburetters, it is advisable to check over the following items.

Ignition timing. Set the "IGN" not (T.D.C.) mark on the flywheel in the centre of the clutch inspection opening and check the timing, as on page 43. Distributor and plug points should be checked for cleanliness and gap, i.e. .015 in./0.018 in. on distributor and .018 in. on plugs, also valve clearance should be .006 in. inlet and .008 in. exhaust between base of cam and rocker.

Having checked these items, remove the suction chambers of carburetters from the carburetters, disconnect the jet coupling rod and screw the jet adjusting nuts right up. On pushing the jets up to the full weak position the correct petrol level should be about $\frac{1}{8}$ in. below the top of the jet. If this is not so, and assuming the floats are in good condition and not punctured, the level can be adjusted by bending slightly the fork controlling the float needle, up to raise or down to lower, whichever is required. Next proceed to set the needle in the pistons.

The shoulder of the needle should be flush with the face of the piston. Refit the pistons and suction chambers to the carburetters, making sure that, when screwed down tight, the pistons will fall on to their seatings with a click. If for any reason it is thought advisable to fit new needles, see that they are the same type as before.

Screw down the jet adjusting nuts two complete turns and screw off slow-running rod. Then slacken one of the flexible coupling bolts on the coupling connecting the throttle spindles. The engine can then be started, screwing down the jet adjusting nuts further is necessary in order to enable it to run. The slow-running screws on the throttle spindles should now be screwed up, and eventually adjusted so that the engine is idling fairly slowly. It is now easily possible by placing the ear to the mouths of the two carburetters to determine whether there is an equal flow of air through them. Adjustment of the slow-running screws should be made until this occurs (that is, until there is an equal "hiss" at the mouth of each carburetter), when the coupling bolt may be retightened.

Before attempting the final adjustment for mixture strength, it is essential that the engine should have attained its normal working temperature. When this is done the mixture may be judged by the exhaust note. If the engine is running with a regular rhythm but suggestive of there being more work done by one cylinder than the others, this phenomenon being accompanied by signs of black smoke from the exhaust, it may be concluded that the mixture is too strong. One of the jet adjusting nuts should now be screwed up, pushing up the jet head to meet it at the same time. If this effects no improvement, return it to its original position and try the same procedure with the other. If, on the other hand, the exhaust note is regular without any perceptible rhythm, it is probable that the mixture is too weak. In this case, first one and then the other of the jet adjusting nuts should be screwed down. The slow-running adjusting screws should now be turned equally in an anti-clockwise direction until the slowest possible tick-over is obtained consistent with even firing. A fairly good check on the mixture strength can be obtained by idling the engine fairly fast, and lifting each of the pistons in turn with a pencil or similar object a height of about $\frac{1}{32}$ in. This should have the effect of causing a very slight increase in engine speed, the evenness of firing not being upset. If on the other hand this operation has the effect of causing the engine to stop, it is an indication that the carburetter is set too weak. If an appreciable increase occurs and continues to occur while the piston is lifted to the extent of, say, $\frac{1}{16}$ in., the indication is that the mixture on this carburetter is too strong, and the jet adjusting nut should therefore be screwed up.

General.—It will be realised from the foregoing that the S.U. carburetter is a very simple instrument and easily managed when understood. On the other hand, considerable damage can be done if it is not treated correctly.

We would emphasise that the four troubles previously outlined are the only ones that can be caused by defects in the carburetter, and if these points are in order the carburetter should on no account be dismantled or altered, since the trouble must lie elsewhere.

DON'T FORGET TO TURN THE PETROL TAP BACK TO THE MAIN POSITION AFTER REFILLING THE TANK.

DON'T RUN THE ENGINE WITH THE MIXTURE CONTROL IN THE RICH POSITION LONGER THAN NECESSARY.

SECTION E

IGNITION

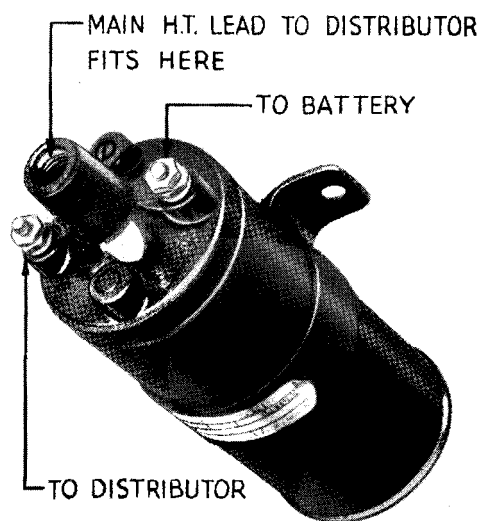

The Distributor

Lubrication

Cleaning and Adjustment

Distributor Timing

Coil

Warning Lamp

Detection and Remedy of Faults

Sparking Plugs

Ignition.—Very little attention is needed to keep the ignition equipment in first class condition. We advise that it is inspected occasionally, and the following instructions on lubrication, cleaning and adjustment are carried out.

Lubrication.—The High Tension distributor is very accessible. It is provided with an oiler to lubricate the spindle, a few drops every thousand miles being sufficient.

About every 3,000 miles, give the cam the slightest smear of vaseline. Also withdraw the rotor from the top of the spindle by lifting it off, and add a few drops of thin machine oil. Do not remove the screw exposed to view, as there is a clearance between the screw and the inner face of the spindle through which the oil passes to lubricate the automatic timing control.

Every 5,000 miles, place a single drop of oil on the contact breaker pivot.

The contacts can be inspected by unclipping the two springs when the cover carrying the High Tension Leads can be removed. The points may require adjustment from time to time, and a spanner is provided with the Tool Kit for this purpose. The clearance between the points should be $15-18/1000$ of an inch when they are fully open.

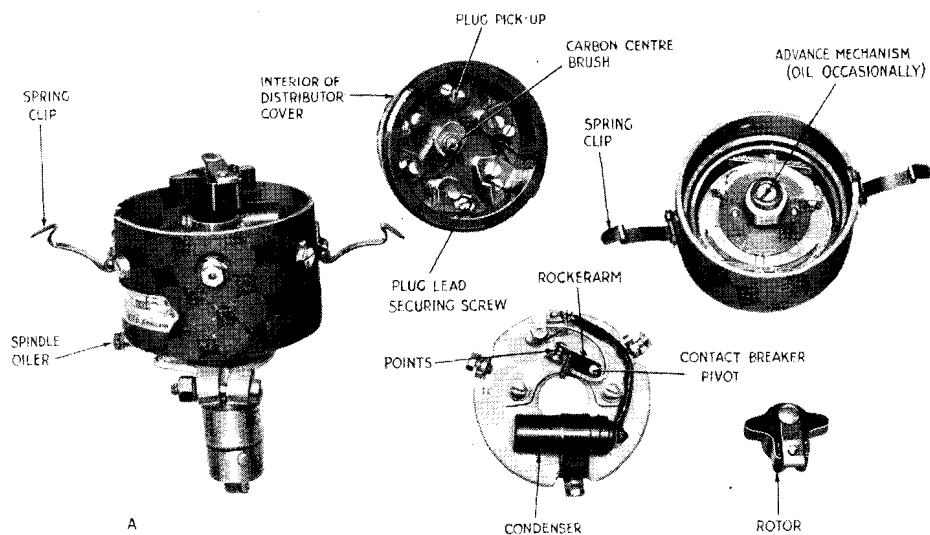

Illustration No. 33.—View of the Distributor with cover removed, showing automatic advance mechanism and various points referred to in the text.

Provided that the cam is kept clean and that the instructions on cam lubrication are carried out, the contact breaker gap will only need adjustment at very long intervals. It is not advisable to alter the setting unless the gap varies considerably from the gauge supplied. If adjustment is necessary, proceed as follows :—When the contacts are fully opened, slacken the locking nut on the stationary contact screw, and rotate it by its hexagon head until the gap is set to the thickness of the gauge. After making the adjustment, care must be taken to tighten the locking nut.

The centre spindle of the High Tension distributor carries a "Bakelite" Arm called the "Rotor." It can only fit on the spindle one way. If this part is removed, it affords an excellent thief proof device, but care should be exercised to see that it does not become chipped or in any way damaged, not to mention lost, after it has been removed. The ends of the high-tension wires are held in position by securing screws from inside the cover. See that the screws are always tight.

Occasionally remove the distributor moulding (by pushing aside its two securing springs). See that the electrodes are clean and free from deposit. If necessary, wipe out the distributor with a dry duster and clean the electrodes with a cloth moistened with petrol. See that the carbon brush is clean and moves freely in its holder. Clean the outside of the moulding, particularly the spaces between the terminals. Next examine the contact breaker ; it is important that the contacts are kept free from any grease or oil. If they are burned or blackened, they may be cleaned with very fine emery cloth and afterwards with a cloth moistened with petrol. Care must be taken that all particles of dirt and metal dust are wiped away. Misfiring may be caused by any of the following :—

1. Dirty sparking plug or plugs.
2. Bad connection to High Tension Leads.
3. Bad connection from High Tension Distributor to Coil.
4. Improper adjustment of or burnt make and break points.
5. Dirt between make and break points.
6. Defective Coil.
7. Faulty condenser, causing repeated burning of points.
8. Temporary petrol starvation.

There is one other remote cause of electrical failure, namely, bad earth contacts from the battery to the frame. Other causes of misfiring can be attributed to Carburetter and incorrect valve adjustment. Separate instructions are given on these last two items elsewhere.

Distributor Timing.—It has been found on test that the ignition timing is fairly critical and that on the average the amount of advance required is equal to exactly $1\frac{1}{2}$ inches measured on the flywheel in advance of the top dead centre mark. It will be found that there is a line on the flywheel marked "Ign"—the engine should be turned by means of the starting handle until the mark is in the centre of the clutch inspection aperture, the points of the make and break in the distributor should then be on the point of opening.

In order that the timing is set correctly it is advised that the setting should always be done using as a guide the line of the flywheel.

To actually time the distributor slacken the nut on the fixing screw "A" in Illustration No. 33, and turn the distributor body in a clockwise direction to retard and anti-clockwise to advance.

Coil.—The coil unit is not adjustable in any way, and requires no attention beyond seeing that the terminal connections are kept tight, and the moulded coil top is kept clean.

Warning Lamp.—A warning lamp is provided in the instrument panel, which gives a red light when the ignition is "ON" and the car is stationary. The warning lamp will also light when the engine is running very slowly, due to the fact that the dynamo is not running at sufficient speed to generate a high enough voltage to actuate the cut-out.

The Detection and Remedy of Ignition Faults.—If a failure of ignition or misfiring occurs, unless the cause is at once apparent the owner is strongly recommended to proceed in accordance with the following routine, which should quickly enable him to locate the trouble.

Before proceeding with the examination, make sure that the trouble is not due to defects in the engine, carburetter, petrol supply, sparking plugs, etc.

Engine will not Fire.—Switch on the ignition, turn the engine and observe the ammeter reading. The engine should be turned by hand if it is known that the battery is in a low state of charge.

If an ammeter reading is given which rises and falls with the closing and opening of the contacts, then the low tension wiring is in order. If the reading does not fluctuate in this way, a short in the low tension wiring is indicated, or the contacts are remaining closed. When no reading is given, a broken or loose connection in the low tension wiring is indicated, or the battery may be exhausted.

Examine the high tension cables, i.e. cables from the coil to the distributor, and from the distributor to the plugs. If the rubber shows signs of deterioration or cracking, the cable should be renewed. Remove the distributor moulding and examine the contacts; if necessary, clean them as described on page 43. Turn the engine over by hand, and see that the contacts come together.

If a fault is indicated in the low tension wiring, examine the cables from the switch or junction box to coil, and from coil to distributor. See that the battery terminals are tight and that the cables from the switch-box to the battery are secure. The battery may be dismissed as the cause of the trouble if the lamps will light.

Test the coil independently of the distributor as follows:—Remove the cable from the centre distributor terminal, and hold it about $\frac{1}{4}$ in. from some metal part of the chassis and turn the engine. The sparking should be strong and regular if the coil is functioning correctly.

Misfiring and Bad Starting.—Examine the high tension cables and the plugs. If necessary, adjust the gaps to the correct setting (about 18 thousandths of an inch). Sooty or oiled plugs may be dismantled and washed out with petrol.

The plugs and high tension cables may be tested by removing the plugs in turn and allowing them to rest on the cylinder head and observing whether a spark occurs at the points when the engine is turned by hand. It should, however, be noted that this is only a rough test, since it is possible that a spark may not take place when the plug is under compression.

If after carrying out the examination suggested, the trouble cannot be found, we advise that the equipment should be examined by the nearest Lucas/Rotax Service Depot, the addresses of which are given later.

Sparking Plugs.—The correct gap is .018", this is the setting used at the factory, and no advantage will be gained by either a wider or a closer gap. A definite mileage when cleaning will be necessary cannot be specified, as there are a number of governing factors. It is, however, wise to leave well alone if there is no indication of trouble in that direction.

Plugs are easily ruined by inexperienced handling. The only satisfactory way of ascertaining whether a plug is sparking correctly is to test it under compression. Most service stations have a "plug tester," and we recommend that M.G. owners have their plugs checked in this way periodically.

A good plan is to keep a spare set of plugs and if plug trouble is suspected to change over to the spares. This allows plenty of time to have the others attended to as suggested.

SECTION F

**CLUTCH AND
GEARBOX**



Clutch Operation

Clutch Adjustment

Clutch Lubrication

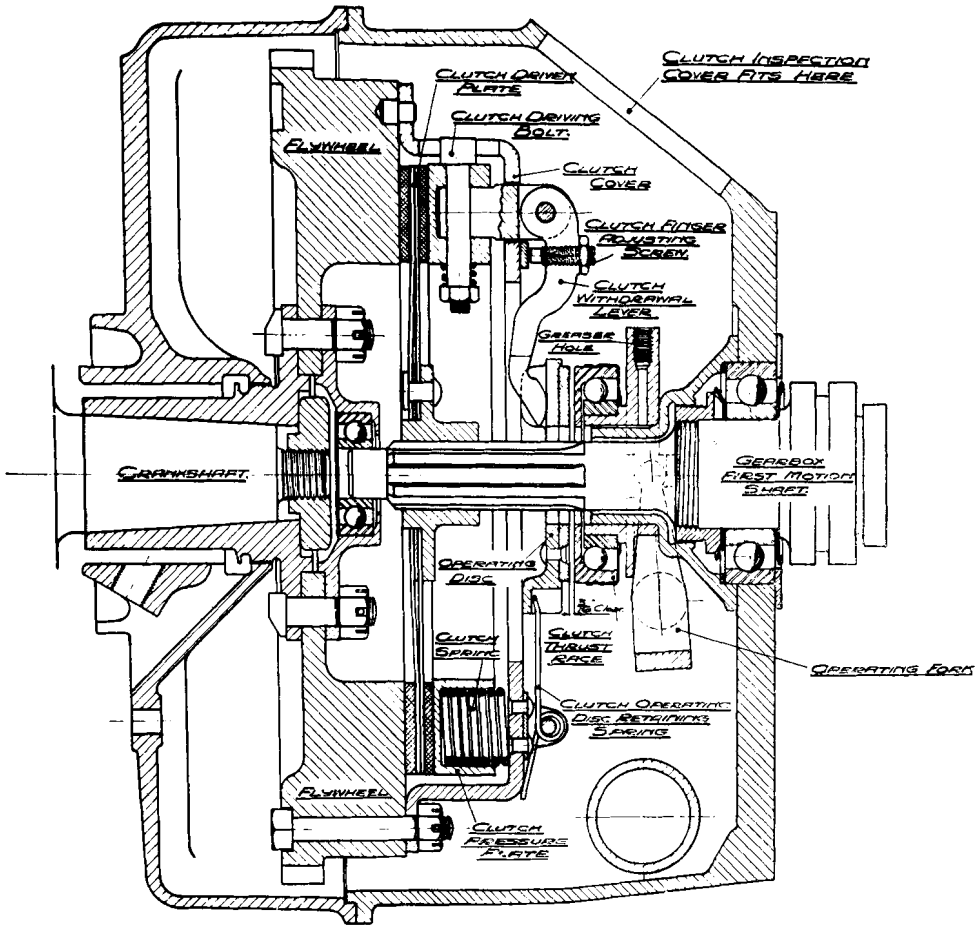

Illustration No. 34.—A diagrammatic illustration of the clutch, showing the various components.

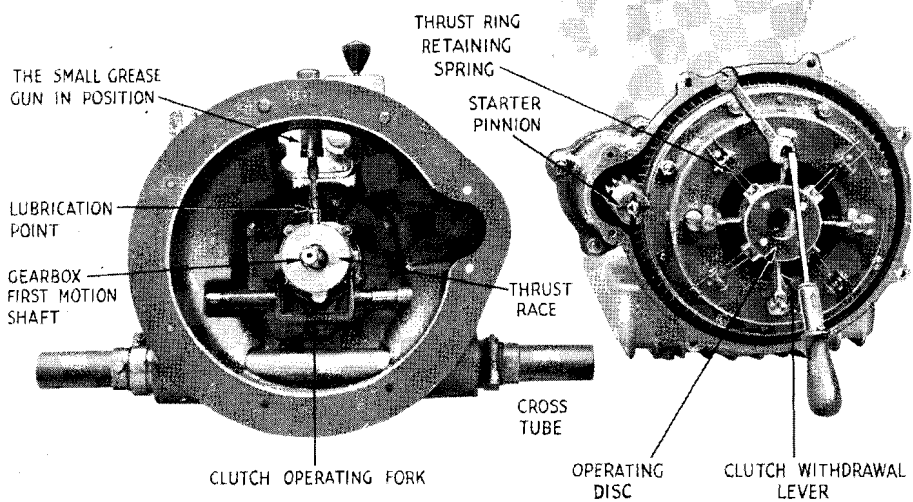

Illustration No. 35.—The clutch in assembled form, showing in particular the lubrication point and the method of adjustment.

Clutch Operation.—In order that the owner may understand the relationship of the various parts, he is referred to Illustration No. 34, which shows the clutch diagrammatically. Various terms are employed to describe the clutch parts by different people, but in the M.G. Works they are described as follows :—

First there is the flywheel, then the clutch driven plate with fabric facings on either side, and next to it the pressure plate. The whole assembly is covered by the clutch cover plate.

The driven plate is made of laminated steel for medium flexibility, and is a sliding fit on the splines of the first motion shaft of the gearbox. There are twelve clutch springs which fit into recesses in the pressure plate, one of which is shown in Illustration No. 34.

It stands to reason that when the clutch is bolted up solid the pressure of the springs will force the pressure plate into contact with the driven plate, and grip the latter between the pressure plate and the flywheel. It is essential that the linings must be free from any lubricant so that they can work effectively, and one can visualise that letting in the clutch with a jerk may rough up the faces of the linings. Alternatively, by letting the clutch continually slip the friction faces will become overheated and have a detrimental effect on the linings.

Clutch Withdrawal.—The clutch is disengaged by means of the clutch withdrawal lever marked on Illustration No. 34. This is operated by the clutch pedal, which in turn operates the fork moving the thrust race forward against the clutch withdrawal lever.

The Clutch Operating Disc.—Between the clutch thrust race and withdrawal lever there is an operating disc fitted with a fabric lining loaded by retaining springs which hold the operating disc against withdrawal levers. The object of this operating disc is to prevent the withdrawal levers being thrown out by centrifugal force and also to ensure a perfectly flat and smooth face for contact with the thrust race. The movement of the withdrawal levers is controlled by adjusting screws which can clearly be seen in Illustration No. 35.

From the foregoing it will be gathered that pressure on the clutch pedal forces the withdrawal levers to fulcrum on their adjusting screws. The ends of the withdrawal levers in contact with the operating disc move in a forward direction, while the opposite ends move in the reverse direction, withdrawing the clutch pressure plate from contact with the driven plate.

Clutch Adjustment.—The action of the clutch having been described, it remains simply to show how adjustment is effected. Access to the clutch is through the inspection cover on the top of the bell housing forward of the gearbox remote control. When removing the cover plate take care not to drop the securing screws into the clutch pit.

It is necessary to limit the travel of the clutch pedal so as to avoid the clutch being pushed out too far. As the clutch gradually wears, the thickness of the fabric rings will decrease, which will cause the driven pressure plates to go nearer to the flywheel. This necessitates the clutch withdrawal set screws being adjusted to give a clearance between the fabric face and the withdrawal disc. The correct clearance is $\frac{3}{16}$ in. when the clutch is engaged and there is no pressure on the clutch pedal.

It is absolutely essential that the four clutch withdrawal lever adjusting screws are adjusted so that the clearance between the operating disc and thrust race opposite each lever is exactly equal in each case, the clearance therefore must be determined by a gauge $\frac{3}{16}$ in. thick and inserted opposite the lever which is being adjusted.

Check the clearance opposite all four levers after they have been adjusted finally, also see that the operating disc runs absolutely true when the engine is running very slowly. Should it be found that with the engine running the operating disc face appears to oscillate fore and aft it is proof that the adjustment has not been carried out evenly on all four fingers and they will have to be re-adjusted.

When adjusting the clutch care should be taken not to drop the spanner or other tools into the clutch pit. It is a wise precaution to secure them with a piece of string before starting to make adjustments.

The clutch pedal stop should, if necessary, be adjusted so that there is $1\frac{1}{2}$ in. clearance between the back of the pedal and the stop when the clutch pedal is in its normal resting position.

Clutch Lubrication.—The only part of the clutch requiring lubrication is the thrust race. This should be lubricated with Duckham's Hardy Spicer grease every 2000 miles, the race has a special grease retainer, so a small quantity only is needed.

Gearbox.—It is thought desirable to deal with the gearbox at some length as it differs in many respects from the orthodox type of box. It has already been seen in various illustrations that the change speed lever is fitted to an extension to the gearbox lid. The gearbox affords four speeds and reverse. The gate is marked so that it is easy for anyone to see the positions of 1st, 2nd, 3rd and top speed gears. In order that the reverse gear shall not be engaged inadvertently, the gate is provided with a stop. The gears are operated by a series of forks coupled to selector rods.

Illustrations Nos. 37 and 38 give the owner an idea of the manner in which the selector rods are locked in position when the gear lever is placed in any of the forward or backward positions. The exterior view of the gearbox should be studied, as it shows the filler on the side of the box which acts as an automatic height level. The drain plug beneath the box can be removed through the trap door in the under-shield by means of the box spanner in the tool kit.

Examination of Illustration No. 36 will show that the clutch withdrawal shaft is supported in the bell housing. Bushes are located therein by means of set screws, and there is an oil hole in either side of the housing for lubrication of the withdrawal shaft ends.

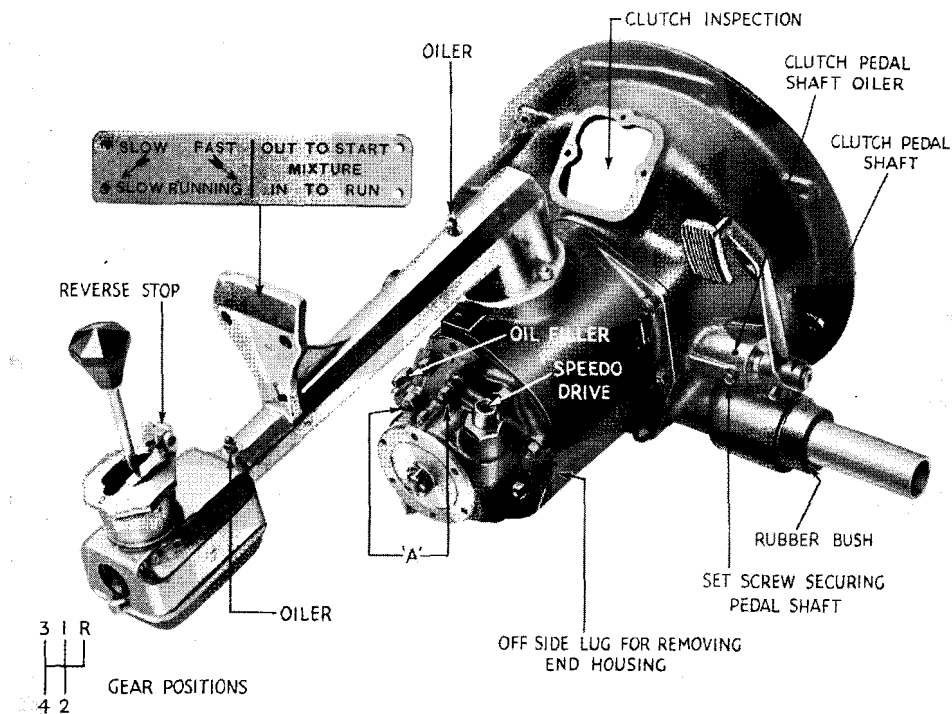

Illustration No. 36.—An external view of the gearbox. The various items shown are referred to in the text matter.

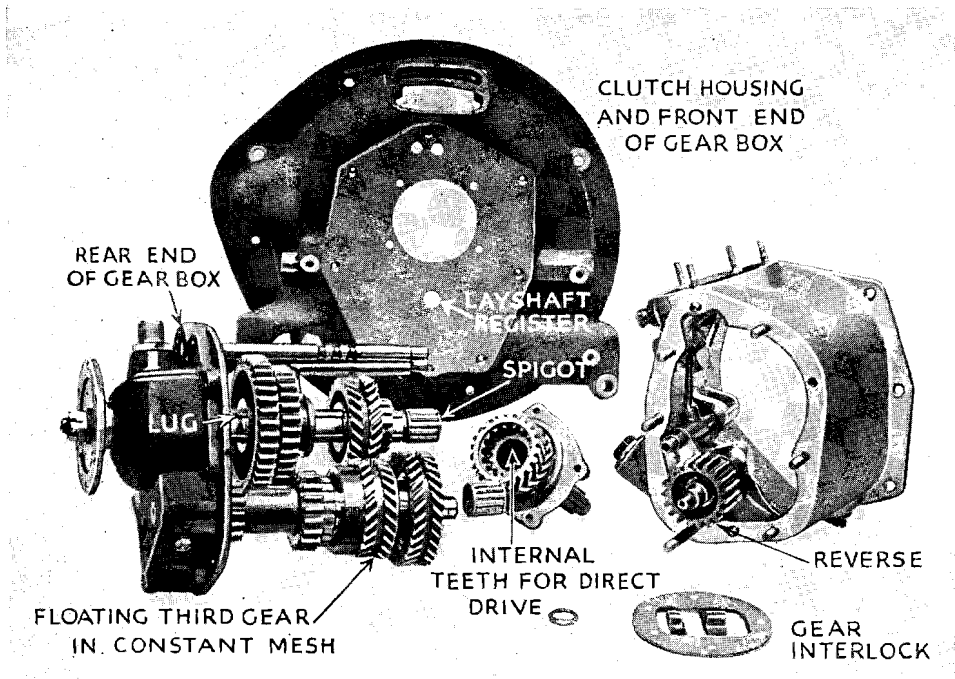

Illustration No. 37.—View of the gearbox partially dismantled, showing the flywheel housing. The centre housing carries the reverse gear and the main and layshafts built up on to the rear end cover. It will be noted that the spigot on the end of the mainshaft has a roller bearing and the layshaft is also mounted on roller bearings. The third speed gear on the layshaft is always in constant mesh with the third speed on the mainshaft.

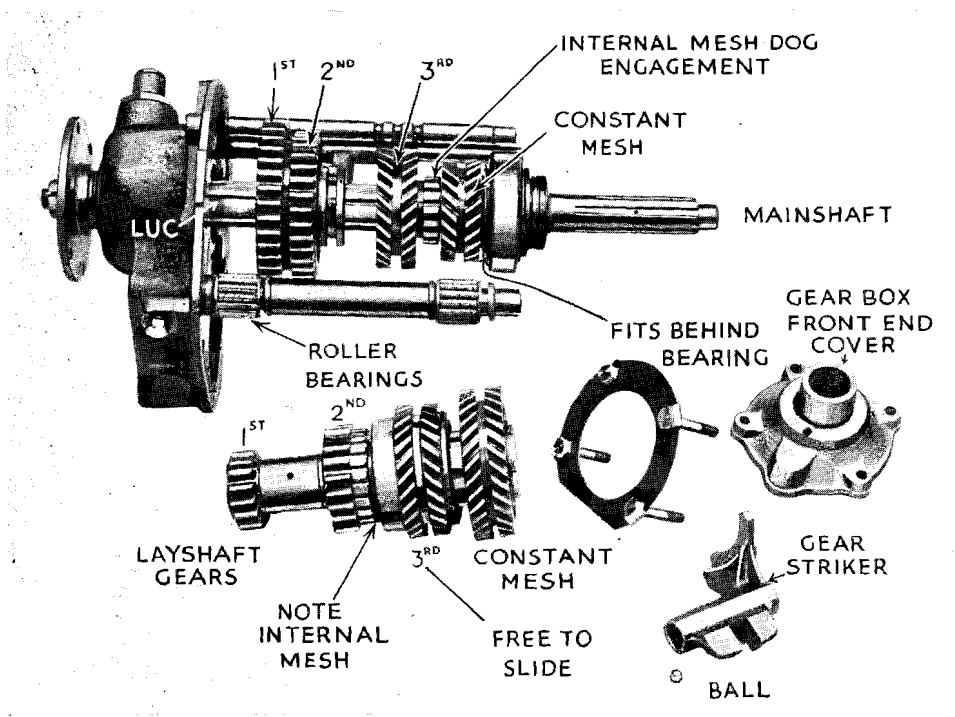

Illustration No. 38.—Another view of the gearbox components. The complete layshaft gears have been removed from the layshaft. Note the internal mesh engagement of the top gear on the mainshaft and the third gear on the layshaft.

In dismantling the gearbox there is no necessity to remove the nuts marked A, and it will be noticed that the rear end housing of the gearbox is provided with lugs, so that the rear end cover cap is removed by tapping on the lugs instead of introducing a tool and damaging the facing.

Steel balls register in slots in the selector rods, and as the gear lever is moved to and fro the balls ride out of one slot and re-engage in another, according to the position of the lever. Looking at Illustration No. 37, one can obtain an excellent idea of the gearbox layout, apart from the gears themselves. It consists of three principal parts ; the front end of the gearbox is formed by the bell housing, the centre of the gearbox acts as casing and a support for the reverse shafting, and the rear end of the gearbox supports the shafts and their gears.

It will be seen that the first and second speed gears, which are on the left of the picture, are of the straight tooth variety, whereas the constant mesh gears and the third speed gears have the teeth cut at an angle, or what is usually called " double helical."

The principal point to note in this illustration is the gear on the lower or layshaft, which is indicated in the illustration as " floating third gear," which is always in constant mesh with the third speed pinion on the mainshaft.

Top gear is obtained in the ordinary way by sliding the third gear on the mainshaft forward, so that the splines on the hub of the gear mesh internally with the constant mesh pinion on the first motion shaft, and it will be noted that the spigot bearing is of the roller type. When, through the movement of the change speed lever, the third speed gear on the mainshaft is caused to slide rearwards, the nature of the tooth engagement will automatically cause the third speed gear on the layshaft to move backwards in unison ; it is then that the gear on the layshaft, which has internal cut teeth, engages with a set of teeth on the front of the second speed pinion. When any other gear is engaged except third gear this third gear on the layshaft simply rotates on its rollers.

In order to make the matter clearer, the reader should now refer to Illustration No. 38, which shows the layshaft train of gears locked up on a tube removed from the layshaft itself. The layshaft is fitted with roller bearings at either end, and over these roller bearings the complete layshaft gear train is fitted.

The internal mesh dog engagements of the direct drive on the mainshaft and the third speed free sliding gear on the layshaft should be examined.

If momentary reference is made to Illustration No. 35 it will be noticed that the mainshaft, or first motion shaft, protrudes through the gearbox, passing through the gearbox front end cover.

This cover will be seen in Illustration No. 38, and alongside this will be found a steel ring with four bolts passing through it. This steel ring is placed behind the front ball bearing on the mainshaft to act as the ball race retaining washer, and it will be also noticed that the ring has a number of lips formed upon it to act as registers for the bolts by which the front end gearbox cover is secured. A small hole is drilled on the lower portion of the front gearbox cover, permitting a certain amount of lubricant to pass through to lubricate the clutch thrust race housing which fits over the extension of the cover.

A gear striker to operate the gears is shown at the lower right-hand corner of Illustration No. 38. It will be noticed that there are two rods above the mainshaft which have grooves in them. These are the selector rods previously mentioned.

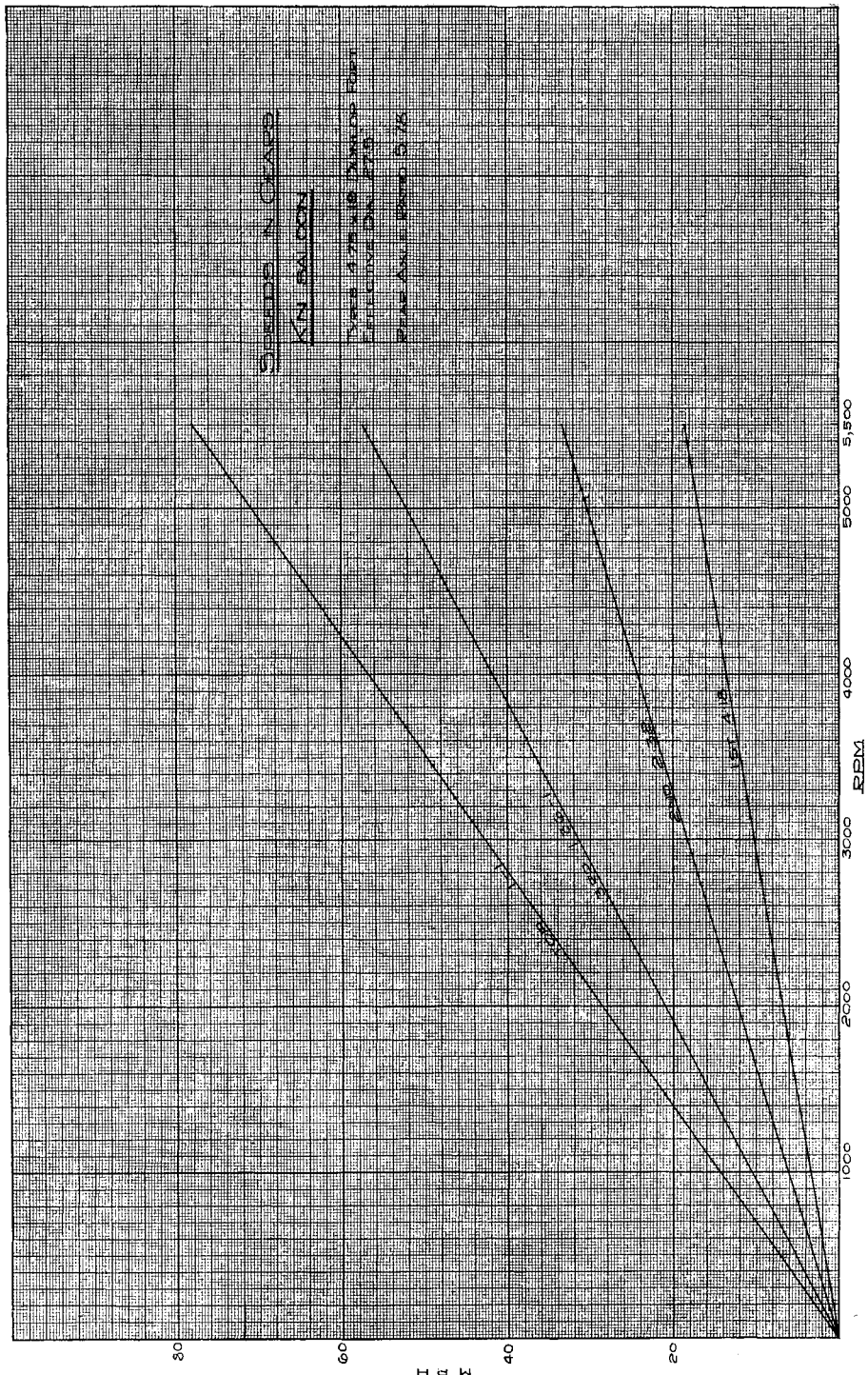

SECTION G

THE CAM STEERING

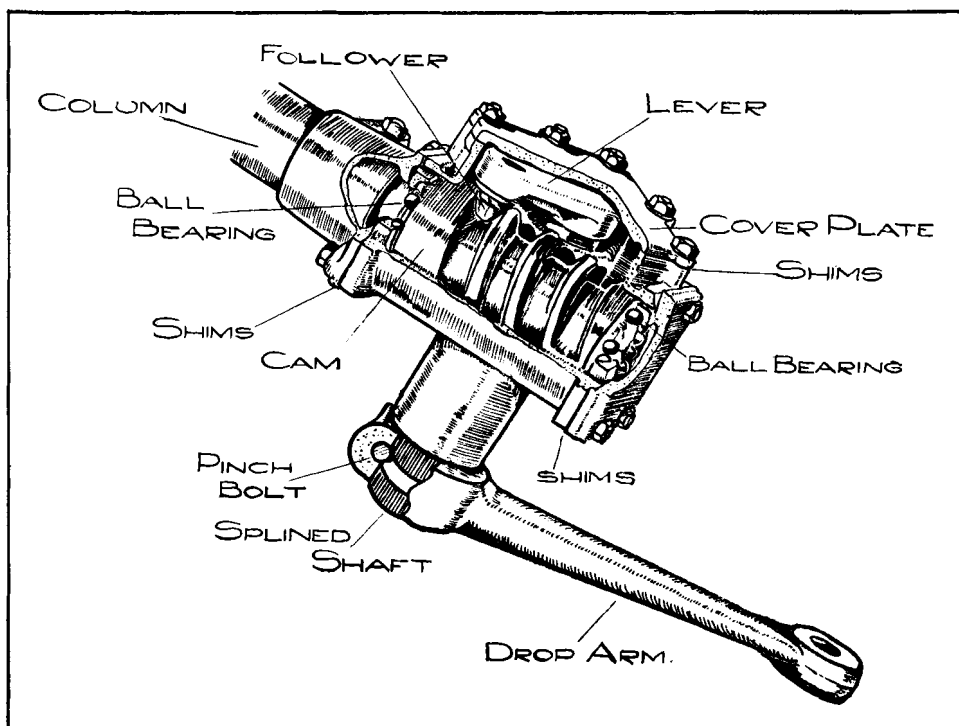

- Steering Lubrication
- Steering Adjustments
- Removal of Drop Arm
- Fitting the Drop Arm

Steering.—The operation of the cam steering gear, which is standard on M.G. Magnette models, is quite straightforward. A cam, in which a spiral groove is cut, is mounted on the shaft carrying the steering wheel. Into this groove is inserted a follower which makes contact with the cam track.

The cam is mounted between special ball bearings expressly designed for the duty they have to perform. The whole mechanism is contained in an oiltight casing and replenishment at intervals is the only attention required.

Lubrication.—On no account must grease be used. The oil is introduced to the internal mechanism of the box from the nipple " C " on the dash wall by means of the oilgun, this point should receive attention every 500 miles.

Adjustments. The Cam.—It will be observed that the cam and mainshaft are mounted on ball bearings which take the thrust from the rocker-shaft, and shims are introduced under each end cover so that cam is mounted centrally in the box. It should never be necessary to alter the adjustment, which is carefully set before the car leaves the Works, but if the gear is dismantled for cleaning or inspection a careful note of the number of shims at each end should be made. On reassembly this shaft should " spin " with the fingers, but there should be absolutely no end play.

The Rocker-shaft. The only adjustment ever likely to be needed is the removal of one or more shims from underneath the cover-plate (see illustration on page 53), covering the lever inside the steering gearbox. The motion of the steering wheel is transmitted to the road wheels through the cam and the follower fitted into the lever, and in time a small amount of wear (as shown by " lost motion " between the steering wheel and the drop arm) may possibly become apparent, but the whole of this can be removed and the gear restored to its original perfection by the removal of one or more of the shims mentioned. If too many shims are removed the gear will become a little stiff in the centre, and this must not be permitted. The follower runs in a hardened steel bush, and these two parts must always be a very close fit, being only just sufficiently free to revolve. All adjustments to the steering gear should be carried out with the draglink disconnected.

Removal of the Drop Arm.—The drop arm is attached to the rocker-shaft on a splined shaft and secured by a pinch bolt which registers in a groove in the shaft. This method of attachment makes the drop arm absolutely secure, but it may be difficult to remove the drop arm from the shaft unless a drawer is used on the lugs provided for this purpose. If difficulty is experienced in removing the drop arm the side cover-plate must be removed first, and the shaft should be driven through the drop arm so that the reaction from the blow is taken on the main casing instead of on the hardened steel cam and roller.

Fitting Drop Arm to Rocker-shaft.—Should it be necessary to remove the drop arm from the rocker-shaft at any time, we recommend that before doing this both these items should be marked so that they can be fitted together again afterwards in the same relative position.

In case this marking has been omitted or obliterated we give below the correct method of fitting, and we would draw attention to this matter, which is of some importance. Should this operation not be properly carried out, most certainly the available lock will be limited in one direction or the other, and damage may result to the internal mechanism of the gear.

The steering column, complete with steering box, but without the drop arm attached, should (if it has been removed) first be fitted in place in the car, taking care to tighten up all fixings holding the unit to the car, including that on the dashboard, the steering wheel being placed in its final position.

Next, the lower end of the drop arm carrying the ball pin should be fixed correctly to the draglink, but the top end should not yet be connected to the rocker-shaft of the steering box.

Now jack up the front wheels and place them in the straight-ahead position.

If the steering wheel is rotated gently you will find that its movement is limited by internal stops in the steering box at each end of the travel of the internal mechanism of the gear. The number of turns of the steering wheel required to bring the gear from one end of its travel to the other should be counted. Then, commencing from one of these stops, take the wheel back half the complete number of turns available, which will bring the steering mechanism into its central position. Then fit the serrated cone in the top of the drop arm to the rocker-shaft.

Before tightening up, however, the following check should always be carried out.

The front wheels still being jacked up, with the steering wheel pull the steering right over to lock, either right or left. With the steering wheel and front wheels in this position drop the draglink off the drop arm and see whether you can move the steering wheel any farther in the same direction. If you can, everything is in order, and the same procedure should then be followed on the other lock.

Should further movement of the steering wheel be unobtainable it means the front axle stops are not operating, and some adjustment must be made as follows :—

If there is movement of the steering wheel available on one lock, but not on the other, the drop arm should be put on the next serration on the rocker-shaft, which may put matters right.

If no serration will give free movement of the steering wheel at both locks, then the front axle stops must be adjusted so that there is.

The amount of free movement available after dropping the draglink off the drop arm should be the same at both locks, and this is the condition at which to aim.

The instructions given in this section may appear complicated, but in reality the operation is one of the simplest character.



SECTION H

ELECTRICAL



Electrical Equipment
Instrument Panel
Cut-out and Junction Box
Electrical Starter
The Dynamo
The Brushes and Commutator
Dynamo Lubrication
Dynamo Field Fuse
Removing Dynamo
Third Brush Regulator
Ammeter, Fuses, Cut-out
Headlamps and Sidelamps
S.U. Petrol Pump

Electrical Equipment.—The electrical equipment of the modern motor-car is often and quite erroneously regarded as something very complex and difficult. Yet in the present day motor-car simple application of thoroughly tried-out ideas has made possible easy adjustment and maintenance of practically all the electrically operated parts. In this section an endeavour has been made to explain the various instruments and the best way to set about adjustments.

The wiring diagram may at first appear to be a little complicated, but it shows clearly exactly where each individual cable goes and the manner in which they are carried from point to point.

Wiring is arranged on the earth return system, and particular care has been taken to ensure that good continuity obtains at all points of the circuit, by the inclusion, where necessary, of independent earthing cables. It will also be noticed that cables at all essential points are encased in flexible metallic armouring. This not only protects the cables from possible abrasion, but excludes road dirt and water, prevents premature wear and makes for long and trouble-free service.

Instrument Panel. The panel—see Illustration No. 41—contains the control switch for the dynamo, ignition and lights, a centre zero ammeter and various other items, all of which are clearly marked. A word of explanation on the dual function of the ignition warning light may prove of assistance. Its obvious object is to warn the owner that the ignition switch is “on” and the battery is being discharged, but, being in effect “shunted” across the cut-out points, it will allow only a very small current of electricity to flow through the armature and field coils of the dynamo, thus giving the dynamo an initial excitation. A resistance is always included in the warning lamp circuit to prevent the voltage rise of the dynamo burning out the bulb, and in the light under consideration the resistance is of sufficient value to permit the use of a small $2\frac{1}{2}$ -volt bulb of considerably longer life than the earlier heavy consumption type.

Cut-out and Junction Box.—A good view of this component can be had by referring to Illustration No. 42. All cables are taken to terminal posts in a recessed space at the back of the box, and it is here that the two main harnessed cables—the panel harness associated with the control panel and the junction box harness which constitutes the cables going to the various points on the chassis—are coupled up. The fuses, reading from left to right, are (S & T) side and tail, (E) dynamo field fuse, (Aux) for the auxiliaries, (H) headlamps. These are so arranged that should a short-circuit develop in any lamp or other component, the fuse associated with that component only will blow and the remainder of the installation will remain normal. The operation of tracing the fault is simplified enormously as it is at once apparent which circuit is at fault. It should be noted that the field fuse is only of 5 amperes.

In the centre of the fuse block the spare fuse carrier is provided with one complete replacement set. At the side of the fuse block a pair of terminal posts are available for coupling up any other instruments fitted subsequently. This pair is fused in the auxiliary circuit and is intended for additional horns, foglamps, etc. It will perhaps be helpful to note here that there are many accessories on the market, some of which take a very high operating current, and the owner should avoid fitting any of these unless approved by a competent electrical engineer. In any case a heavy current accessory must be connected directly to the battery and not through the junction box or ammeter.

Fuses.—It will be noticed that the fusing of the lamps is such that there is no risk of the driver being plunged into total darkness. If both the headlamps, or the side and tail-lamps, or all the units connected to the auxiliary accessory terminal fail to function, examine the particular fuse protecting them.

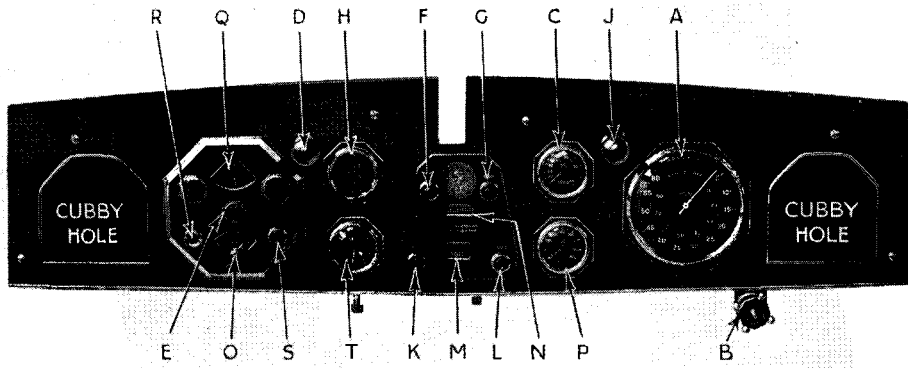
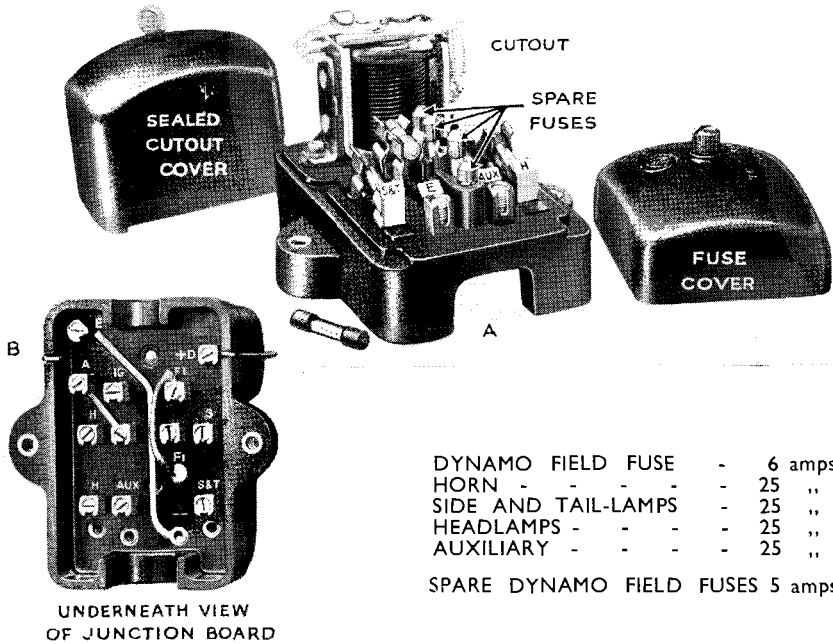

Illustration No. 41.—The facia board.

- | | | |
|------------------------------------|------------------------|----------------------------|
| A. Revolution counter. | G. Dashlamp switch. | N. Mileometer. |
| B. Petrol tap. | H. Petrol gauge. | O. Lamp and dynamo switch. |
| C. Oil thermometer. | J. Dashlamp. | P. Oil gauge. |
| D. Dashlamp. | K. Trafficator (N.S.). | Q. Ammeter. |
| E. Ignition switch (key-operated). | L. Trafficator (O.S.). | R. Ignition warning light. |
| F. Foglamp switch (spare). | M. Mileometer (trip). | S. Starter switch. |
| | T. Clock. | |



DYNAMO FIELD FUSE	-	6	amps.
HORN	-	25	"
SIDE AND TAIL-LAMPS	-	25	"
HEADLAMPS	-	25	"
AUXILIARY	-	25	"
SPARE DYNAMO FIELD FUSES 5 amps.			

Illustration No. 42.—The fuse box and cut-out with details of the various fuses.

Remove the fuse from its holder and see whether there is a break in the fuse wire. Before replacing the fuse, inspect the units that have failed, for evidence of short circuits or other faults that may have caused the fuse to blow.

If a fuse blows repeatedly, and the cause cannot be traced, we advise that the equipment is examined by a Lucas/Rotax Service Station.

The Cut-out.—The function of the cut-out is to close the charging circuit, as the increased engine speed when the car is starting causes the dynamo voltage to rise above that of the battery. When the engine slows down, the dynamo voltage falls below that of the battery, and the reverse action takes place, i.e. the cut-out opens and thereby prevents the battery from discharging itself through the dynamo.

The question is sometimes asked whether the operation of the cut-out in any way depends upon the state of charge of the battery. There is no such relation between the two; the sole function of the cut-out is to switch on the dynamo with rising engine speed and to disconnect it when the engine slows down to below a certain speed. The cut-out, which is housed under a separate cover at the top of the junction box, see Illustration No. 42, is entirely self-operating and is accurately adjusted by the makers before fitting. It should operate for a considerable period without attention, and because considerable damage to the entire installation could be done by anyone attempting to vary the setting it is sealed by the manufacturers.

Ammeter.—The centre-zero ammeter which is incorporated in the instrument panel indicates the actual current flowing into or out of the battery. For instance, suppose two amperes are consumed when the side and tail-lamps are switched on, and the ignition coil takes one ampere, then if the dynamo is generating at seven amperes the meter will show four amps. on the charge side of the scale. This is the current in excess of the lamp and ignition load which is available for battery charging purposes.

Dynamo.—The dynamo is mounted on a platform at the front end of the engine and forms part of the overhead camshaft drive. Reference to Illustration No. 17 shows its actual application, and Illustration No. 25 shows how it is driven and removed. Two views of the dynamo can be seen in Illustrations No. 43/4. It will be seen that the pinion is held on to a shaft by a nut and tab washer which registers in the hole in the pinion. The dynamo is what is known as a simple shunt machine and has been designed to stand up to the very high revolutions per minute and acceleration movement. Beyond an occasional inspection of the brush gear it requires but little attention. The brush gear can be examined by slackening off the screw holding the cover in position. The cover is shown in Illustration No. 43 beside the dynamo.

Brushes.—It is very important to make sure that the three brushes work freely in their holders. This can easily be ascertained by holding back the spring and gently pulling each flexible lead, when the brush should move without the slightest suggestion of sluggishness. The brushes should be clean and should "bed" over the whole of their working surface; that is to say, the face of contact with the commutator should appear uniformly polished. Dirty brushes may be cleaned with a cloth moistened with petrol.

If any of the brushes become so badly worn that it is necessary to replace them, this is accomplished by releasing the brush lead eyelet by removal of the screw, then, while holding the spring lever back out of the way, withdrawing the brush from its holder. The new brush can then be fitted by reversing the operation.

When ordering new brush replacements state whether they are main or control brushes (third brush, illus. 43) and for what type of machine they are required, also chassis and engine numbers.

The brush springs should be inspected occasionally to see that they have sufficient tension to keep the brushes firmly pressed against the commutator when the machine is running. It is particularly necessary to keep this in mind when the brushes have been in use for a long time and are very much worn down.

Owners are cautioned that it is unwise to insert brushes of a grade other than that supplied with the machine, or to change the tension springs. The arrangement provided has been made only after many years' experience, and will be found to give the best results.

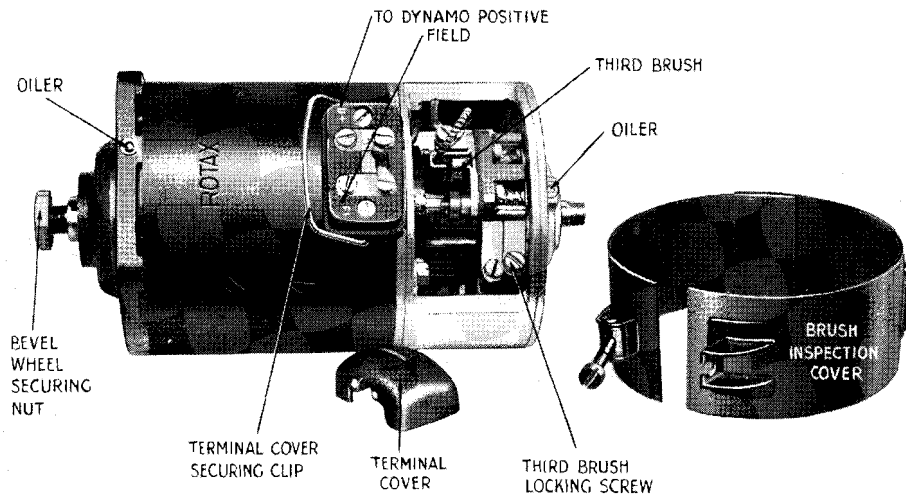

Illustration No. 43.—A view of the dynamo showing the position of one of the lubricating holes, the third regulating brush and its locking screw. The instructions should be read carefully concerning the care of the commutator and brushes and the regulation of the dynamo.

Lamp	Bulb	Filament*	Voltage	Wattage
Headlamps	S.P.	V.	12-v.	36 w.
Sidelamps	S.P.	C.S.	12-v	6 w.
Tail-lamp	S.P.	C.S.	12-v	6 w.
Stop Lamp	S.P.	C.S.	12-v.	6 w.
Foglamp	S.P.	V.	12-v.	36 w.
Dashlamps	S.P.	C.S.	12-v.	6 w.
Ignition Light	M.E.S. 252A.	—	2.5-v.	—
Direction Indicators ...	T.126 Festoon	—	12-v.	6 w.

* V indicates a special filament arranged to give the best focus with the lamps. C.S.= centrally supported filament ; these should be insisted upon when buying replacement bulbs.

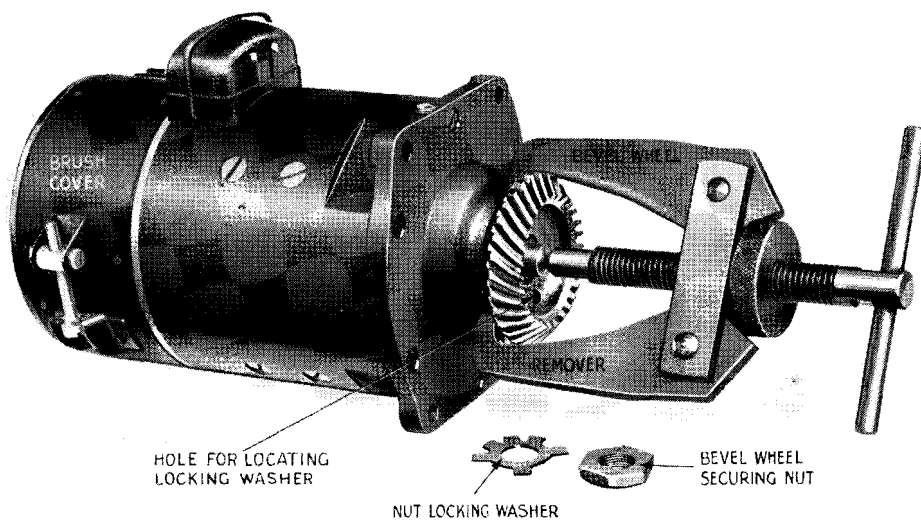

Illustration No. 44.—View of the dynamo showing the method of withdrawing the gear from the shaft.

Commutator.—The surface of the commutator should be kept clean and free from oil and brush dust, etc. ; neglect of this precaution will result in the commutator becoming blackened, causing sparking to occur at the brushes, and consequent shortening of the life of the machine. The best way to clean the commutator is to insert a fine duster, held by means of a suitably shaped piece of wood, against the commutator surface, slowly rotating the armature by the starting handle at the same time.

If the commutator has been neglected for long periods, it may need cleaning with fine glass paper; but this is more difficult to do, and should not be necessary if it has received regular attention. The grooves between the commutator segments should be examined occasionally and any deposit of copper or carbon dust may be cleaned out by means of a thin saw blade or similar article. The owner is strongly advised to entrust this operation to a fully qualified electrician, as serious damage can unconsciously be done by anyone not familiar with this class of work.

Lubrication.—As the bearings are packed with grease before leaving the Works, very little attention is needed. A few drops of oil, however, may be added through the lubricators provided, say, every 1,000 miles. The reader is cautioned that far more trouble has been caused by excessive oiling than by too little. (After the car has run about 20,000 miles the dynamo should be removed, cleaned and adjusted and the bearings repacked with grease. This should be entrusted to the nearest Lucas/Rotax Service Depot.

Dynamo Field Fuse.—A fuse is provided in the dynamo field circuit to protect the machine in the event of anything being wrong in the charging circuit, e.g. a loose or broken battery connection. If the dynamo fails to charge the battery at any time (indicated by the ammeter giving a discharge reading during daytime running), inspect the fuse and, if it has blown, replace it. If the new fuse blows after starting up, the cause of the trouble must be found, and we advise that the equipment is examined by a Lucas/Rotax Service Station. Replacement fuses must be of the same size as those originally fitted.

Removing the Dynamo.—In order to obtain easy access to the dynamo for removal it is desirable, although not absolutely necessary, to take off the radiator. Remove the lock nuts and nuts from the radiator bolts carried through the engine nose piece extension, and the bolts retaining the yokes of the bonnet tie rods. Also, after emptying the water system, remove the top and bottom water connections. It is unnecessary to interfere with any of the oiling system to remove dynamo.

Between the projecting portion of the cylinder head and the top of the dynamo will be found a circular flexible coupling. Remove the nuts on each of the four coupling bolts in turn, leaving the bolts in position, so that the coupling can be rotated by use of the starting handle to bring each bolt into a position where the nut may easily be reached.

Having removed all four nuts, take off the clutch inspection cover and turn the engine by the starting handle until the timing marks on the flywheel are in the centre of the aperture. This will bring the driving yoke on the cylinder head across the engine, and the driving yoke on the dynamo parallel to the engine centre line. The bolts themselves may now be withdrawn, care being taken not to lose the distance washers, which must be replaced in the same position. Removal of the bolts enables the flexible coupling to be withdrawn.

Detach the two cables on the distributor side of the dynamo, noting from which terminal they are removed.

Now unscrew the four set screws which attach the dynamo to its platform at the front of the engine, thus releasing the dynamo. Lift the dynamo approximately a quarter of an inch and tilt it towards the near-side of the car until the driving yoke on the dynamo is just clear of that on the cylinder head. The dynamo can then be tilted forwards and easily withdrawn. (See Illustration No. 25).

Replacement of the dynamo is effected in the reverse way, but it is necessary to make sure that the engine timing has not been disturbed while the dynamo was removed. Removal of the rectangular cover-plate in the clutch housing should reveal the timing mark on the flywheel for Nos. 1 and 6 cylinders, exactly in the centre of the opening. Place the brass packing shims which fit under the dynamo base in position on the dynamo platform, making sure that you replace the same number that you took off. If for any reason the dynamo is replaced by another, it may be necessary to readjust the mesh of the driving gears to obtain silent running by suitable selection of the packing shims used. Turn the dynamo spindle until the timing mark on the dynamo drive gear coincides with the centre line of the dynamo and is at the rear—that is, ready for engagement with the correspondingly marked teeth of the drive gear on the crankshaft. The holes in the dynamo coupling yoke will then be parallel with the engine centre line. Tilting the dynamo towards the near-side of the car and holding the dynamo coupling yoke in this position, insert the drive gear into the opening of the dynamo platform and swing the dynamo backwards and downwards into position. The gears can be felt to be meshing properly if the coupling is slightly oscillated as the dynamo is replaced, but do not overdo the oscillations or you may engage the wrong teeth.

See that the bolts in the dynamo base are coinciding with the holes in the dynamo platform, and then observe if the dynamo coupling yoke is exactly parallel to the engine centre line. If it is not, withdraw the dynamo, reset the coupling yoke and re-insert the dynamo. No difficulty should be experienced in getting the dynamo in position with the correct teeth in mesh, as the distance between one tooth and the next is sufficient to make an appreciable difference to the position of the dynamo coupling yoke, a difference which is immediately discernible.

Having satisfied yourself that the correct gear teeth are in mesh, replace the screws in the dynamo base, taking particular care to tighten them up evenly a partial turn at a time until all are quite tight. Now make a final test. The flywheel mark 1—6 should show exactly in the centre of the inspection cover opening with the distributor rotating arm pointing towards No. 1 cylinder. (This can easily be found by tracing the high-tension lead from No. 1 sparking plug to its junction on the distributor. Removal of the distributor cover should show the distributor arm directly beneath it). The dynamo coupling bolt holes should be exactly fore and aft and at right angles to the coupling yoke on the cylinder head, and No. 1 inlet and exhaust valves should be closed.

If all the foregoing are correct, replace the flexible coupling and coupling bolts, taking care to replace the distance washers in exactly the same position as they were originally. Tighten up the nuts firmly and rotate the engine slowly by hand. If the distance washers are in the correct position, the flexible coupling should run absolutely true. If it does not do so, note where the error is and adjust the distance washers accordingly. Then replace the valve cover and attach the dynamo cables on to their correct terminals.

Dynamo Adjustment.—The output of the dynamo—that is to say, its rate of charge—is controlled by a third brush which is shown quite clearly in Illustration No. 43. All machines are adjusted to an output of 9 amperes before leaving the Factory, and any marked variation from this standard usually indicates some other factor at fault which must be cleared before normal conditions are possible for the dynamo. Should, however, the indicated charging rate increase to a value above 10 amperes **with all lights out**, it is necessary to reduce this at once, as a continuation of high output will rapidly destroy the machine. It is inadvisable for anybody who is not an electrician to tamper with this. To reduce the output the third brush or control brush must be moved in a direction opposite to that of rotation. To move the brush it is necessary to slacken the stud marked “Locking Screw” in Illustration No. 43, and when the adjustment has been satisfactorily effected it is important to make sure that the stud is tightened.

The third brush is to be found on the near-side of the car and on the same side as the small ball covered lubricator. Never omit to tighten up the lock screw after any adjustment has been effected, and don't try to undo or tighten the lock screw with pliers.

Headlamps.—The **L.B.150** headlamps manufactured by Messrs. Joseph Lucas Ltd. are specially designed to give the highest illuminating factor without unduly overloading the electrical installation. The near-side lamp is equipped with a permanently deflected reflector and is always in circuit when the headlamp switch is on. The off-side lamp has a straight focus reflector, and while primarily wired in the same circuit as the other, can also be controlled by the dipping switch. The lamps are carefully focussed before leaving the Factory so that the near-side lamp will throw a slightly open beam and thus effectively illuminate the road and kerb up to about 40 yards, while the off-side beam is relatively closely focussed to throw a penetrating light ahead.

It should be noted that when a bulb is changed it is usually necessary to re-focus the beam. This can be effected by removing the front by slacking off the retaining screw A at the bottom of the lamp, and then removing the cork washer, taking care not to damage it, and the reflector which is held in position by one screw, when the small cheese-head screw holding the bulb holder can be loosened. The bulb holder can then be moved either forwards or backwards until the correct beam is obtained. It is essential that the cheese-headed screw should be effectively tightened when the correct focus is obtained, otherwise the light will be erratic.

Wiring Headlamps.—Remove the front and reflector. Then depress the insulating washer on the bulb holder terminal against the spring until the cable hole is exposed. Thread the cable end through the hole, release the pressure on washer, when the cable will be securely held in position and good contact made. Cables should not be pushed too far through the terminal, as there is a danger of shorting on to the reflector or body of the lamp.

Sidelamps.—The fronts of the wing lamps are secured by small grub screws ; when these are removed the fronts can be withdrawn by first pulling the top forward.

Replacement of Bulbs.—When the replacement of any bulb is necessary the following are the correct bulbs to use :—Headlamps, 12 v.—36 w. Blue Star ; Side and tail-lamps, 12 v.—6 watts. (See page 61.)

Cleaning Lamps.—The reflectors are protected by a transparent and colourless covering, which enables any accidental finger marks to be removed with chamois leather or a soft cloth without affecting the surface of the reflector. Do not use metal polishes on Lucas reflectors. Chromium plated lamps will not tarnish and only need wiping over with a damp cloth to remove dust or dirt.

Electric Starter.—The engagement consists of a coarse threaded shaft on which a pinion is fitted. When the starter button is pressed the starter motor rotates quickly, causing the pinion to be rotated; but owing to the form of this pinion it has a tendency to travel along the starter extension shaft, and thus engage with the teeth of the flywheel, the shock being taken up by a recoil spring.

The moment the engine starts up and the self-starter button is released the flywheel rotation causes the pinion to travel back along the starter shaft out of engagement.

The front end of the self-starter shaft is provided with a square end, and it is possible in the case of only a slight jam to rotate this spindle with a spanner and thus disengage the starter pinion from the flywheel. The above explanation will be made clearer on examining Illustration No. 46, which shows the starter removed from the engine. It is held in position by two studs and one bolt, and there is a distance plate between the starter housing and the flywheel housing. The flywheel teeth can be seen and also the spiral thread on the extension of the starter shaft, along which the engaging pinion travels to and fro ; the recoil or buffer spring is clearly visible.

If, for any reason, the pinion wheel on the motor does not engage with the flywheel teeth, examine the screwed sleeve on the armature spindle to see that it is free from dust ; if necessary wash over with paraffin. Occasionally, give it a few drops of thin machine oil.

As in the case of the dynamo, the surface of the commutator must be kept clean and free from oil, brush dust, etc.

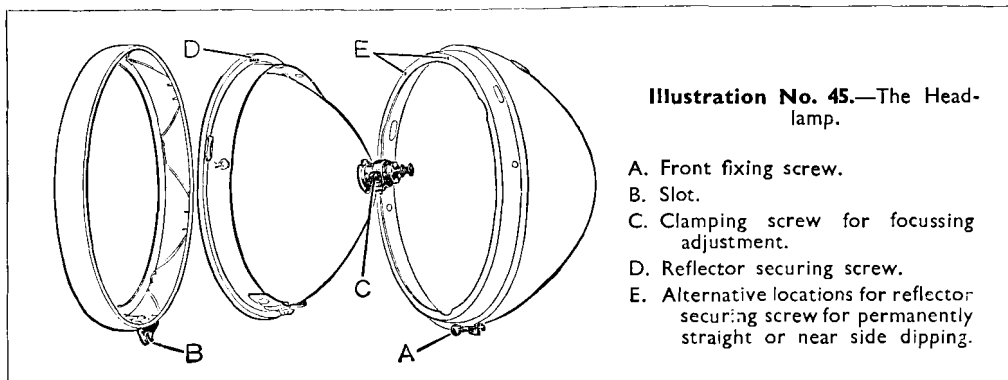

The starter is designed for starting the engine under normal conditions, but any unnecessary or additional loading will considerably diminish the life of the machine and battery. In order to facilitate starting in cold weather, it is advisable, before using the electric starter, to crank the engine over slowly by the starting handle for two or three revolutions; this will break the oil film and considerably diminish the load for starting. By pushing out the clutch when using the starter the load of the gearbox is taken off the starter and the engine turns faster and more easily.

If the solenoid “clicks” but the starter refuses to work and the rest of the electrical installation apparently is in order, check over the battery leads where they connect to the battery or earth on the frame, as a loose connection at this point causes such a high resistance that insufficient current is passed to work the starter.

Battery.—It is of the utmost importance that the battery should receive regular attention, as upon its good condition depends the satisfactory functioning of the ignition, starting motor, and the lamps.

At least once a month the vent plugs in the top of the battery should be removed and the level of the acid solution examined. If necessary, distilled water (which can be obtained at all chemists and most garages) should be added to bring the level well above the plates. If, however, acid solution has been spilled, it should be replaced by a diluted sulphuric acid solution of specific gravity 1.320. It is

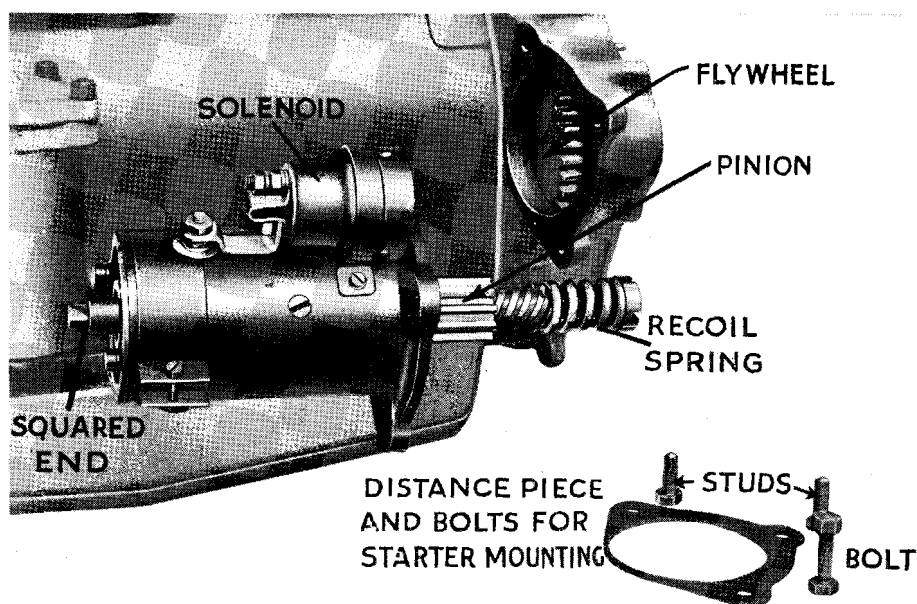

Illustration No. 46.—The self-starter, showing the method of operation and its fixing, and the solenoid switch fitted on the top.

important, when examining the cells, that naked lights should not be held near the vents, on account of the possible danger of igniting the gas which is generated by the plates. It is advisable to complete the inspection by measuring the specific gravity of the acid, as this gives a very good indication of the state of the charge of the battery. An instrument known as the hydrometer is employed for this purpose ; these can be bought from your Dealer or from any of the Lucas/Rotax Service Stations.

For the battery the specific gravity readings will be 1.285—1.300 for a fully charged battery, about 1.210 when half discharged, and about 1.150 when fully discharged.

If one cell gives a reading very different from the rest, it may be that electrolyte has been spilled or has leaked from this cell, or there may be a "short" between the plates. In the latter case, the battery should be examined as soon as possible by a Lucas/Rotax Service Station.

Finally, see that the tops of the cells are clean and dry, and that the terminals are tight and smeared with vaseline.

If the equipment is laid by for several months, the battery must be given a small charge from a separate source of electrical energy about once a month, in order to obviate any permanent injury to the plates.

Under no circumstances must the acid be removed from the battery and the plates allowed to dry, as certain changes take place which result in loss of efficiency.

The battery must never be left in a fully discharged condition, and, unless some long runs are to be taken, it is advisable to have the battery removed from the car periodically and charged up from an independent electrical supply.

The Electric Petrol Pump.—The pump is fitted on the off-side of the dash wall and consists of three main assemblies: the body, the magnet assembly and the contact breaker. The body is composed of a hollow brass stamping "A" into the bottom of which the filter "B" is screwed. The inlet union "C" is screwed in at an angle on one side. The outlet union "D," which is screwed into the top, tightens down on to the delivery valve cage "E," which is clamped between two fibre washers "F" and "G." In the top of the cage is the delivery valve, a thin brass disc "H" held in position by a spring clip "I." Inserted in the bottom of the cage is a light spring "J," which rests on the suction valve "K," the latter being a similar disc resting on a seating machined in the body. Holes connect the space between the valves to the pumping chamber, which is a shallow depression on the forward face of the body. This space is closed by a diaphragm assembly "L," which is clamped at the outside between the magnet housing "M" and the body, and in the centre between a brass plate "K1" and the steel armature "O." A bronze rod "P" is screwed through the centre of this and passes through the magnet core to the contact breaker which is located at the far end.

The magnet consists of a cast iron pot having an iron core "Q," on which is wound a coil of copper wire which energises the magnet. Between the magnet housing and the armature are fitted eleven spherical edged brass rollers "S." These locate the armature centrally within the magnet at all times and allow absolute freedom of movement in a longitudinal direction.

The contact breaker consists of a small bakelite moulding carrying two rockers "U" and "UI," which are both hinged to the moulding at one end and are connected together at the top end by two small springs arranged to give a "throw over" action. A trunnion is fitted into the centre of the inner rocker, and the bronze rod "P" connected to the armature is screwed into this. The outer rocker "UI" is fitted with a tungsten point which makes contact with a further tungsten point on a spring blade "V." This spring blade is connected to one end of the coil and the other end of the coil is connected to the terminal "W." A spring, "SI," is interposed between the armature and the end plate of the coil.

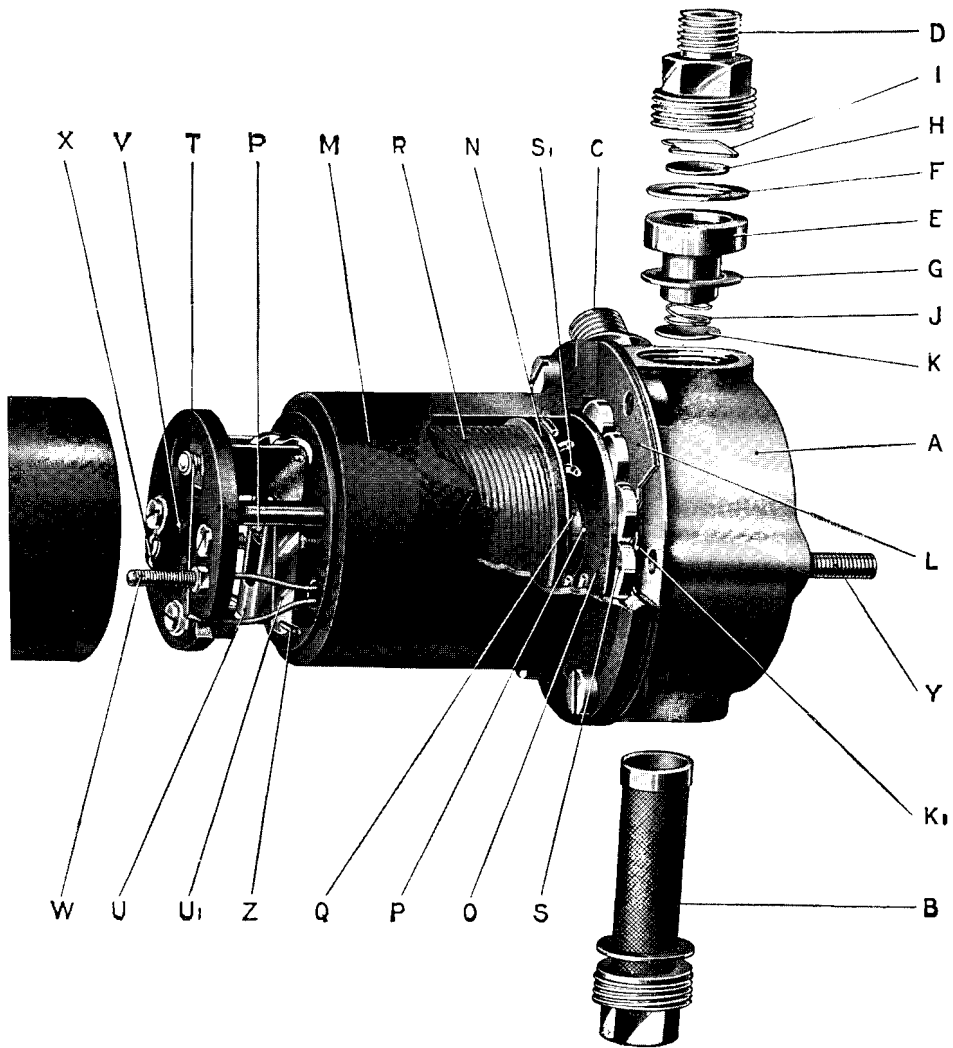

Illustration No. 47.—A view of the S.U. pressure petrol pump with part of the cover cut away to show the magnet. The various letters are referred to in the accompanying text.

A short length of flexible wire is connected to the outer rocker and to one of the screws which hold the bakelite moulding on to the magnet housing, in order to ensure a good earth. In the case of double pole pumps this wire is taken to a further terminal and the rocker mechanism is insulated by fibre bushes. Two fibre bushes are in any case fitted to one of the spindles of the "throw over" mechanism of all pumps in order to silence the operation on the contact breaker.

The action of the pump is as follows. When the pump is at rest the outer rocker lies in the outer position and the tungsten points are in contact. The current passes from the terminal, through the coil, back to the blade, through the points

and to earth, thus energising the magnet and attracting the armature. This comes forward, bringing the diaphragm with it and sucking petrol through the suction valve into the pumping chamber. When the armature has advanced nearly to the end of its stroke the "throw over" mechanism operates, and the outer rocker flies back, separating the points and breaking the circuit. The spring "S1" then pushes the armature and diaphragm back, forcing petrol through the delivery valve at a rate determined by the requirements of the engine. As soon as the armature gets near the end of its stroke the "throw over" mechanism again operates, the points again make contact, and the cycle of operations is repeated.

The spring blade rests against a small projection on the bakelite moulding, and it should be so set that when the points are in contact it is deflected back from the moulding. The width of the gap at the points is of no importance.

If the magnet is removed from the body for any reason care should be taken that the rollers "S" do not drop out. If the armature and centre rod have been unscrewed it will be necessary to reset these. In order to do this the magnet should be held in the left hand and the first finger used to hold the spring blade out of contact with the rocker. The armature should be screwed in as far as possible and should then be screwed back gradually and pressed in and out until it is found that when it is pushed in the "throw over" mechanism operates. It should then be turned back a further four holes. The setting is now correct. The six screws which hold the magnet to the body may then be screwed into place, but before tightening these down the hinge pin "Z" on which both rockers pivot should be pulled out, thus allowing the inner rocker and the armature and diaphragm assembly to move further back. The screws may now be tightened and the hinge pin replaced.

In the unlikely event of trouble, disconnect the lead from the terminal and connect a length of wire to some part of the pump body. Attach a testing bulb to the end of this wire, and then complete the circuit with the lead taken off the pump terminal. If the lamp lights when the ignition is switched on, this wiring is in order. If there is no current the trouble must be looked for elsewhere. If the current is there remove the bakelite cover and touch the terminal with the lead. If nothing happens and the points are in contact and a spark cannot be struck off the terminal it is probable that there is some dirt on the points. If on the other hand the points are not in contact look to see if the tips of the inner rocker "U" are in contact with the magnet housing. If they are not it indicates that the armature has not gone right back. To cure this loosen the six screws which hold the magnet housing to the body, make sure that the diaphragm is not sticking to the magnet housing by passing a penknife down the side of it and remove the hinge pin "Z." The six screws may then be tightened up again, when it will probably be found that the tips of the inner rocker are making contact with the magnet housing. If they are not it will be necessary to remove the whole magnet assembly, dismantle it and see if any foreign matter has caused a jam.

If the pump becomes noisy, look for an air leak on the suction side. To do this, first of all make sure that the filter and inlet union are tight, and also see that there is sufficient petrol in the tank. If this does not cure it, it is probable that the leak is somewhere in the pipe line, and the simplest way to test for this is to replace the suction pipe with a short length of piping and let the pump suck petrol out of a can. If the pump functions satisfactorily under these conditions the fault must be elsewhere. If the pump goes on beating without delivering any petrol it is probable that a piece of dirt has lodged under one of the valves. This may be removed by unscrewing the top union from the body and lifting the valve cage out. If the pump struggles to pump and gets very hot, it is probable that there is an obstruction somewhere in the pipe line or the filter may require cleaning.

SECTION J

BODY HINTS



Washing

Chromium Plate

Tar Removing

Upholstery

Carpets

General Body Hints

Body Maintenance.—The following information will assist the owner to preserve the cellulose, chromium plating, and general body fittings.

Washing.—It is best to use a hose for washing the cellulose, but if this is not available use a sponge and plenty of water ; a brush will be found best for the wire wheels. After washing, the car should be dried thoroughly with a chamois leather. Periodically polish the cellulose with a good quality polish.

Before commencing washing it is a wise precaution to apply the brakes, this prevents to some extent water penetrating between the friction surfaces ; even so, it is wise to test the brakes afterwards, as it may be necessary to dry them out before travelling fast : this is done by running slowly with the brakes partly applied for a while.

Chromium Plate.—Do not attempt to polish the chromium plated parts with metal polish or other form of abrasive. They should periodically be washed, and after drying with a chamois leather, polished with a soft dry cloth. Special chrome polish is obtainable and its use is recommended.

Tar.—Remove if possible before it is dry with a good tar remover, obtainable at most garages. Do not attempt to use petrol or chemicals likely to have injurious effects on the cellulose.

Upholstery.—Very occasionally remove the surface dirt with a damp (not wet) cloth. A good quality furniture cream sparingly applied is beneficial, but it must be thoroughly rubbed into the leather, otherwise it will collect the dust.

Carpets.—These should be removed from time to time and brushed thoroughly (don't beat them). Grease spots, etc., may be removed with petrol or benzine.

General.—Freedom from body noises will result from an occasional check of the body securing bolts to ensure that they are tight. It is as well at the same time also to "go over" the hinge fixing screws, the door locks and their stops. A few drops of oil on the hinges or on the metal parts where movement takes place will often eliminate an elusive squeak. Do not forget sometimes to lubricate the bonnet hinge and fasteners.

THE M.G. MAGNETTE TOOL EQUIPMENT

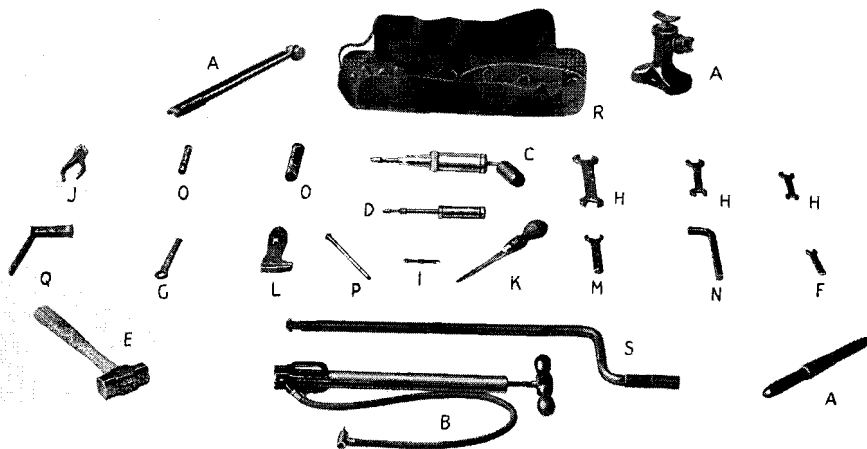

Illustration No. 48

- | | |
|---|----------------------------------|
| A. 1 Jack and handle. | K. 1 Screw-driver, 10". |
| B. 1 Pump and handle. | L. 1 adjustable spanner. |
| C. 1 large grease gun. | M. 1 Tappet spanner. |
| D. 1 small grease gun. | N. 1 Sump wrench spanner. |
| E. 1 Rudge-Whitworth wheel hammer. | O. 3 Box spanners. |
| F. 1 Single-ended spanner 1/8" Whit. | P. 1 Tommy bar for box spanners. |
| G. 1 ring spanner (cylinder head nuts). | Q. 1 Plug spanner. |
| H. 3 double-ended spanners. | R. 1 Tool roll. |
| I. 1 Distributor spanner. | S. Starting handle. |
| J. 1 pair pliers, 6". | |

The tools are packed away behind the seat squab in the two-seater model and in the box beneath the bonnet in the four-seater. The starting-handle is fitted on the dash wall support inside the cockpit.

LUCAS—C.A.V.—ROTAX SERVICE DEPOTS

In the event of any difficulty with any part of the electrical equipment, no matter how trivial, you can be assured of every assistance possible. The best course to adopt is to call at the nearest Lucas Service Depot, the addresses of which are given below, when the equipment can be examined as a whole. The depots are not only at your disposal for repairs, overhauls and adjustments, but to give free advice. When it is necessary, however, to communicate, or to order spare parts, always give the type and number of the unit in question, and the make, model and date, etc., of the car concerned.

BELFAST	3-5 Calvin Street, Mount Pottinger
Telephone : Belfast 7017	Telegrams : " Servdep, Belfast "
BIRMINGHAM, 18	Great Hampton Street
Telephone : Central 8401 (10 lines)	Telegrams : " Lucas, Birmingham "
BRIGHTON	85 Old Shoreham Road, Hove
Telephone : Preston 3001 (4 lines)	Telegrams : " Luserv, Brighton "
BRISTOL	345 Bath Road
Telephone : Bristol 76001 (4 lines)	Telegrams : " Kingly, Bristol "
CARDIFF	54a Penarth Road
Telephone : Cardiff 4603 (4 lines)	Telegrams : " Lucas, Cardiff "
COVENTRY	Priory Street
Telephone : Coventry 3068	Telegrams : " Lucas, Coventry "
DUBLIN	Portland St. North, North Circular Road
Telephone : Drumcondra 434 (6 lines)	Telegrams : " Luserv, Dublin "
EDINBURGH, 11	32 Stevenson Road, Gorgie
Telephone : Edinburgh 62921 (4 lines)	Telegrams : " Luserv, Edinburgh "
GLASGOW	227-229 St. George's Road
Telephone : Douglas 3075 (5 lines)	Telegrams : " Lucas, Glasgow "
LEEDS	64 Roseville Road
Telephone : Leeds 28591 (5 lines)	Telegrams : " Luserdep, Leeds "
LIVERPOOL, 13	450-456 Edge Lane
Telephone : Old Swan 1408 (4 lines)	Telegrams : " Luserv, Liverpool "
LONDON	Dordrecht Road, Acton Vale, W.3
Telephone : Shepherd's Bush 3160 (10 lines)	Telegrams : " Dynamagna, Ealux, London "
LONDON	757-759 High Road, Leyton, E.10
Telephone : Leytonstone 3361 (4 lines)	Telegrams : " Luserdep, Walt, London "
LONDON	155 Merton Road, Wandsworth, S.W.18
Telephone : Putney 5131 (6 lines) & 5501	Telegrams : " Luserv, Put, London "
MANCHESTER	Talbot Road, Stretford
Telephone : Longford 1101 (5 lines)	Telegrams : " Lucas, Stretford "
NEWCASTLE-ON-TYNE, 2	64-66 St. Mary's Place
Telephone : Central 25571 (3 lines)	Telegrams : " Motolite, Newcastle-on-Tyne "

In addition there are Lucas—C.A.V.—Rotax Official Battery Service Agents, genuine Spares Stockists and Dealers, in important centres throughout the country. Additionally there is a very widespread chain of Lucas—C.A.V.—Rotax Overseas Service Stations and Agents throughout the world. Full lists on application to us or Joseph Lucas Ltd., Birmingham.

M.G. DISTRIBUTORS

BARROW-IN-FURNESS.—Simpsons Ltd., 91-93 Duke Street.
BEDFORD.—Arthur Gell, 6a St. Loyes.
BIDEFORD.—Heard Bros. Ltd., Westcombe Works.
BIRMINGHAM.—P. J. Evans Ltd., John Bright Street.
BOURNEMOUTH.—Knott Bros. Ltd., 214 Charminster Road.
BRADFORD.—Waterhouse & Sons, 75 Manningham Lane.
BRIGHTON.—Mansfields Ltd., Kingsway, West Hove.
BRISTOL.—Welch & Co. Ltd., Redcliffe Garage.
BURNLEY.—Hebden Bros., Accrington Road.
CAMBRIDGE.—H. Robinson Ltd., Regent Street.
CARDIFF.—City Motor Co. Ltd., 99-101 City Road.
CARLISLE.—Graham & Roberts, 63 Botchergate.
CHELTENHAM.—Imperial Motor Mart.
COVENTRY.—S. H. Newsome & Co. Ltd., Corporation Street.
CROYDON.—Smiths Auto Co. Ltd., 145 London Road.
DORKING.—Dorking Motor Co. Ltd., Myrtle Road.
EASTBOURNE.—Parkinson, Polson & Co. Ltd., 25-27 Cornfield Road.
GRIMSBY.—Roland C. Bellamy Ltd., South St. Mary's Gate.
GUILDFORD.—Haslemere Motor Co. Ltd., Woodbridge Road.
HULL.—A. B. Motor Co., Pease Street, Anlaby Road.
LEEDS.—Pointing Ltd., Albion House, Albion Street.
LIVERPOOL.—Colmore Depot, Russell Buildings, School Lane.
LONDON.—University Motors Ltd., Stratton House, Piccadilly, W.1.
 ,, Jarvis & Sons Ltd., Victoria Crescent, Wimbledon, S.W.19.
MAIDENHEAD.—Hewens Garages Ltd.
MANCHESTER.—J. Cockshoot & Co. Ltd., Great Ducie Street.
NEWCASTLE.—Frank Scott Ltd., Central Garage, Carloli Square.
NORTHAMPTON.—A. Mulliner Ltd., Bridge Street.
NORWICH.—Mann, Egerton & Co. Ltd.
NOTTINGHAM.—C. H. Truman & Co. Ltd., 61a Mansfield Road.
OXFORD.—The Morris Garages Ltd., St. Aldates.
PETERBOROUGH.—Turnhill North & Co. Ltd., 113 Bridge Street.
PRESTON.—Merigold Bros. Ltd., 147-8 Church Street.
SHEFFIELD.—Pointing Ltd., Moore Street, Eccleshall.
STAFFORD.—Attwoods Garages Ltd., Automobile Engineers.
SWANSEA.—C. K. Andrews Ltd., Uplands Garage.
SWINDON.—Skurrays Ltd., The Square.
TUNBRIDGE WELLS.—Rock, Thorpe & Watson Ltd., Grosvenor Road.
WATERLOOVILLE.—Wadham Bros. Ltd.
WHITCHURCH.—Joseph Hopley & Sons, Doddington.
WIGAN.—H. H. Timberlake Ltd., Automobile Engineers.

ISLE OF MAN

DOUGLAS.—Athol Motor Garage, Hill Street.

SCOTLAND

EDINBURGH.—The Scottish Motor Traction Co. Ltd., 71 Lothian Road.
GLASGOW.—C. S. Grant Ltd., 39 West Campbell Street.

IRELAND

BELFAST.—Victor Ltd., 17-19 Queen Street.

M.G. RADIATOR MAIN SERVICE STATIONS

1. **BELFAST.** Serck Radiators Ltd., 59 May Street.
Telephone : 6938. Telegrams : "Serckrad, Belfast."
2. **BIRMINGHAM.** Coventry Radiator & Presswork Co. Ltd., 140/144 Brearley Street.
Telephone : Aston Cross 1623. Telegrams : "Covradco, Birmingham."
3. **BRISTOL.** Alfred J. Rees & Son, Bishop Street, Moorfields.
Telephone : 56074/5.
4. **CARDIFF.** Serck Radiators Ltd., 60a Clive Road, Canton.
Telephone : 6124 (Central). Telegrams : "Serckrad."
5. **CORK, I.F.S.** J. Gibson & Co., Kyrls Quay.
Telephone : Cork 183.
6. **COVENTRY.** Coventry Radiator & Presswork Co. Ltd., Raglan Works, Lower Ford Street.
Telephone : 3071 (3 lines). Telegrams : "Covradco, Coventry."
7. **DUBLIN, I.F.S.** George Pappin & Sons Ltd., 7 Upper Stephen Street.
Telephone : 51607.
8. **LEEDS.** Excelsior Motor Radiator Co. Ltd., Oldfield Lane.
Telephone : Armley 38041-2. Telegrams : "Cooling, Phone, Leeds."
9. **LIVERPOOL.** Liverpool Radiator Co. Ltd., Fontenoy Street.
Telephone : Central 382-3. Telegrams : "Liveradco, Liverpool."
10. **LONDON, N.W.10.** Serck Radiators Ltd., Park Royal Road.
Telephone : Willesdon 6041 (4 lines). Telegrams : "Serckrad, Phone, Haries."
11. **MAIDSTONE.** Serck Radiators Ltd., Palace Avenue.
Telephone : 2035. Telegrams : "Serckrad."
12. **NEWCASTLE-ON-TYNE.** Serck Radiators Ltd., Skinnerburn Road.
Telephone : 33863. Telegrams : "Serckrad."
13. **NOTTINGHAM.** Minerva Motor Radiator Co., Boulevard Works, Radford.
Telephone : 75631. Telegrams : "Motorad, Nottingham."
14. **SHEFFIELD.** The Excelsior Motor Radiator Co. Ltd., Thomas Street.
Telephone : 22361/2. Telegrams : "Cooling, Phone, Sheffield."
15. **STOKE-ON-TRENT.** Coventry Radiator & Presswork Co. Ltd., 56a Ashford St.
16. **SOUTHAMPTON.** Serck Radiators Ltd., Ryde Terrace, Floating Bridge.
Telephone : 3560. Telegrams : "Serckrad."
17. **SUDBURY, Suffolk.** Serck Radiators Ltd., Cornard Works.
Telephone : 57. Telegrams : "Serckrad."

M.G. RADIATOR SUB SERVICE STATIONS

1. **ABERDEEN.** Francis Craigmile & Son, 56 Gordon Street.
Telephone : 3599. Telegrams : "Radiators, Aberdeen."
2. **BOURNEMOUTH.** Hants & Dorset Sheet Metal Co., 154 Ashley Road.
Telephone : Boscombe 840.
3. **BRIGHTON.** Brighton Motor Sheet Metal Works, 50a St. James Street.
Telephone : 2191-2.
4. **CARLISLE.** Serck Radiators Ltd., Hardwick Circus, Lowther Street.
Telephone : 1119. Telegrams : "Serckrad."
5. **EDINBURGH.** Alder & Mackay Ltd., Stewart Terrace.
Telephone : 61151-2. Telegrams : "Alder, Edinburgh."
6. **EXETER.** Saunders & Biss Ltd., 172 Sidwell Street.
Telephone : 3813. Telegrams : "Radiators, Exeter."
7. **GLASGOW, C.4.** Serck Radiators Ltd., 399 Parliamentary Road.
Telephone : Douglas 3062. Telegrams : "Serckrad."

M.G. RADIATOR SUB SERVICE STATIONS—*continued*

8. **HULL.** Paragon (Hull) Motor Co. Ltd., Boothferry Road.
Telephone : Central 36842-3. *Telegrams* : "Benzina."
9. **KILMARNOCK.** Serck Radiators Ltd., 11 Sturrock Street.
Telephone : 747. *Telegrams* : "Serckrad, Kilmarnock."
10. **LEICESTER.** Victory Radiator & Welding Works, Woodgate.
Telephone : 20180, 20189.
11. **LEIGH-ON-SEA.** J. Keeling & Son, Scarborough Drive, London Road.
Telephone : 75229.
12. **LIVERPOOL.** W. Watson & Co. (Liverpool) Ltd., 7 Mount Pleasant.
Telephone : 5480 Royal (6 lines). *Telegrams* : "Berliet, Liverpool."
13. **MANCHESTER.** H. O. Serck Ltd., Lyon Street, Garratt Street, Oldham Road.
Telephone : Collyhurst 1541 (2 lines). *Telegrams* : "Serckrad."
14. **MANCHESTER.** Pendleton Radiator Co., 72a Broad Street, Pendleton.
Telephone : Pendleton 709. *Telegrams* : "Necessity, Manchester."
15. **NEWCASTLE-ON-TYNE.** C. G. S. Buist Ltd., St. Mary's Place.
Telephone : Kenton 69141.
16. **NORTHAMPTON.** Central Sheet Metal Co., 12a St. Michael's Road.
Telephone : 676.
17. **NORWICH.** W. F. Smith & Sons, 90 King Street.
Telephone : Norwich 30.
18. **PERTH.** Leslie & Murray, St. Catherine's Road.
Telephone : 770.
19. **PLYMOUTH.** Edmund Metal Works, Sutton Road.
Telephone : 2181. *Telegrams* : "Edmund Metal Works, Plymouth."
20. **WOLVERHAMPTON.** Baggott's Motor Fittings, Steelhouse Lane.
Telephone : 110.

RECOGNISED M.G. RADIATOR REPAIRERS

1. **BIRMINGHAM.** Serck Radiators Ltd., Warwick Road.
Telephone : Victoria 0531 (5 lines). *Telegrams* : "Serckrad."
2. **BRIGHTON.** J. Lancaster Radiators Ltd., 56 High Street.
Telephone : Brighton 1256.
3. **BRISTOL.** Perry & Fudge, Globe Works, Horsefair.
Telephone : 22345. *Telegrams* : "Ventilator, Bristol."
4. **CHESTER.** Serck Radiators Ltd., Kaleyards, Frodsham Street.
Telephone : 878. *Telegrams* : "Serckrad."
5. **CROYDON.** J. Richards & Sons Ltd., Wellesley Road.
Telephone : 0456. *Telegrams* : "Richards, 0456, Croydon."
6. **LINCOLN.** W. Hindle & Co., 70 Kesteven Street.
Telephone : 679.
7. **LONDON, W.I.** J. Lancaster Radiators Ltd., 151 Wardour Street.
Telephone : Gerrard 4404-5.
8. **MANCHESTER.** C. W. Scrouther & Co., Talbot Mills, Ellesmere Street, Hulme.
Telephone : BLA. 9452.
9. **PRESTON.** E. Ashwell & Son, 12 Walker Street.
Telephone : 5139 Preston.
10. **SOUTHAMPTON.** J. Lancaster Radiators Ltd., 71 Lyon Street, Onslow Road.
Telephone : Southampton 3372.
11. **SWANSEA.** B. T. Rees, 53a Oxford Street.
Telephone : 5484.

NOTES



CHASSIS NUMBER.....

ENGINE NUMBER.....

BODY NUMBER.....

REGISTRATION NO.....

NAME.....

ADDRESS.....

.....

DATE.....

AGENT.....

**PLEASE FILL IN AND QUOTE REFERENCES IN
CORRESPONDENCE WITH THE FACTORY AND
WHEN ORDERING PARTS.**

Address—

**THE M.G. CAR COMPANY LTD.
ABINGDON-ON-THAMES, BERKSHIRE**

Telephone : Abingdon 251 (4 lines)
Telegrams : "EMGEE"

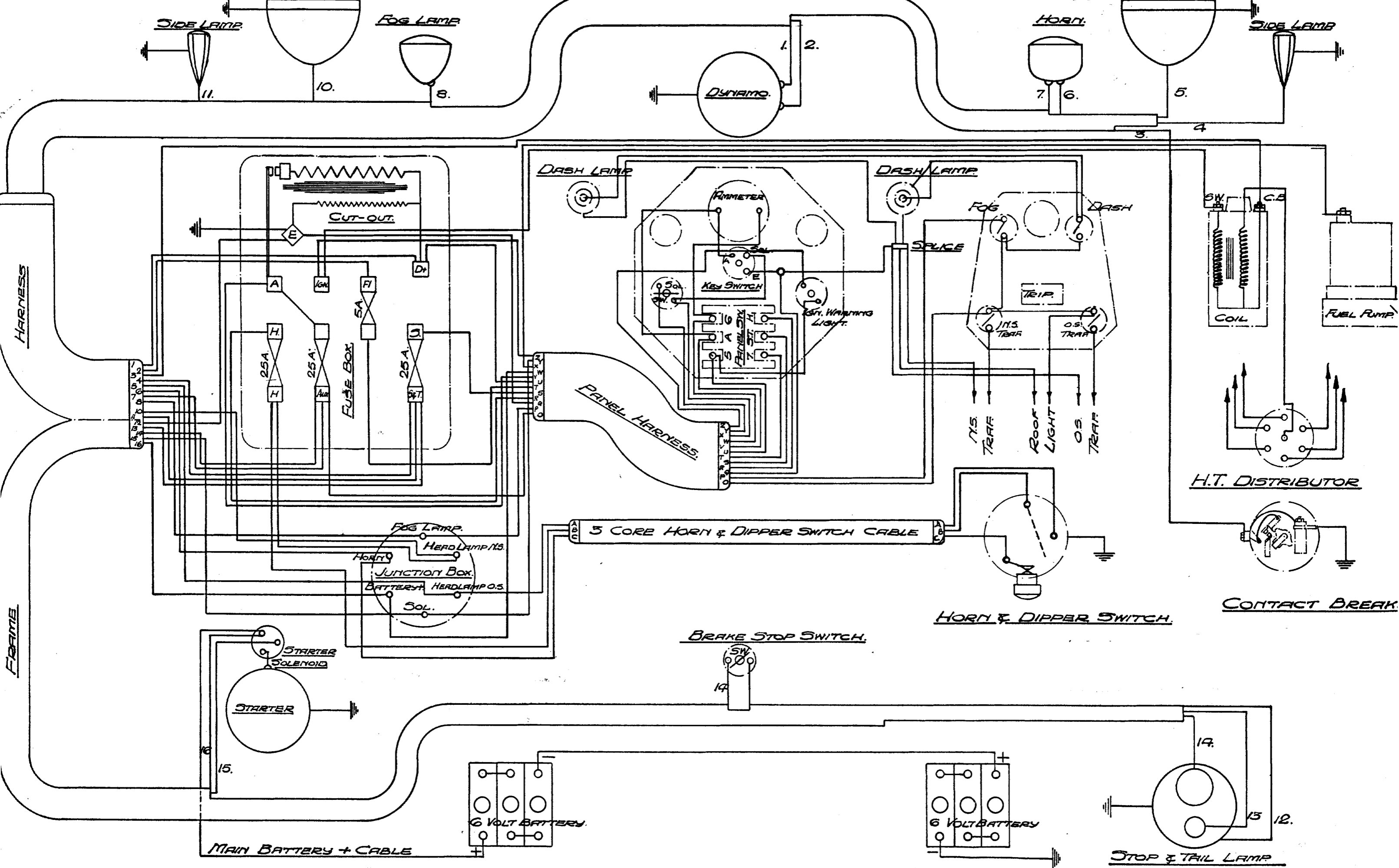

WIRING DIAGRAM FOR THE MAGNETTE "KN" TYPE