

**The
Manual
of the**



Midget

Price 5/- net

Instruction Manual

for the



Midget Sports Car

1931



The M.G. Car Company, Ltd.

Telephone 251



Telegrams "Emgee"

Abingdon-on-Thames

CONTENTS.

FOREWORD

									PAGE
SECTION I GENERAL DRIVING AND MAINTENANCE									
	Preliminary	SECTION I			1
	Petrol	"			1
	Oil	"			2
	Water	"			2
	Cleaning	"			2
	Fabric Bodies	"			3
	Wheels and Tyres	"			3
	Valve Cap	"			4
	Valve Interior	"			4
	Starting	"			6
	Gear Changing	"			7
	The First Thousand Miles	"			9
	Miscellaneous Driving Hints	"			12
 SECTION II LUBRICATION									
	Engine	SECTION II			1
	Draining the Sump	"			3
	External Oil Filter	"			3
	The Oil Restrictor	"			5
	Clutch Thrust	"			6
	Gearbox and Back Axle	"			6
	The Ignition Distributor	"			6
	Chassis Generally	"			6
	Wheel Hubs	"			8
	Brands of Oil	"			9
 SECTION III ADJUSTMENTS									
	Valve Timing Chart	SECTION III			1
	Engine	"			2
	Dismantling	"			2
	Decarbonising	"			4
	Removing the Valves	"			4
	Reassembling the Valves	"			6
	Replacing the Camshaft	"			7
	Adjusting the Rockers	"			7
	Replacing the Cylinder Head	"			8
	Rocker Clearance	"			10
	Engine Bearings	"			10
	Clutch	"			10
	Steering Gear	"			12
	Shock Absorbers	"			12
	Brakes	"			13
	Brake Adjustment Generally	"			13

CONTENTS—Continued.

	PAGE
SECTION IV THE CARBURETTER	
The Carburetter	SECTION IV 1
Adjusting	" 2
Sources of Trouble	" 3
Piston Sticking	" 3
Water or Dirt	" 4
Removing the Jet	" 4
Replacing and Centring the Jet	" 4
Float-Chamber Flooding	" 6
General	" 6
 SECTION V COIL IGNITION EQUIPMENT	
Distributor	SECTION V 1
Lubrication	" 2
Coil	" 2
Warning Lamp	" 2
Detection and Remedy of Ignition Faults	" 3
Engine will not Fire	" 3
Misfiring and Bad Starting	" 4
 SECTION VI ELECTRIC LIGHTING AND STARTING SYSTEM	
Dynamo	SECTION VI 1
Brushes	" 2
Commutator	" 2
Lubrication	" 3
Dynamo Field Fuse	" 3
Removing the Dynamo	" 3
Starting Switch	" 6
Starter Motor	" 6
Battery	" 7
Switches	" 8
Ammeter	" 9
Combined Junction-Box, Cut-out and Fuse Unit	" 9
Fuses	" 9
The Cut-out	" 10
Headlamps	" 11
Removing the Front and Reflector	" 11
Wiring Headlamps	" 13
Side-Lamps	" 13
Tail-Lamps	" 13
Cleaning Lamps	" 14
Replacement of Bulbs	" 14
Lucas Altette Horn	" 14
Electric Windscreen Wiper	" 15
 LUCAS SERVICE DEPOTS	
MAINTENANCE SUMMARY	
M.G. RADIATOR SERVICE STATIONS	
M.G. MAIN AND SUB-AGENTS	
LIST OF SPARE PARTS	
STANDARDISED REPAIR CHARGES	

Foreword.

“A little help is worth a great deal of pity.” We have, therefore, compiled this Manual in an endeavour to be of assistance to the majority of M.G. Owners. It is neither too technical nor too elementary. If you look upon this book as your friend, you will not be let down by theories, but have in your possession hard definite facts. If the information is not sufficient, either consult an Authorised M.G. Agent or write to us direct.

The M.G. Sports Car is built for enthusiasts by enthusiasts. We can, therefore, meet on common ground, and be of mutual assistance.

IMPORTANT

THE attention of owners of new M.G. Midget Sports cars is drawn to the following.

The importance of carefully running-in a new engine cannot be over-estimated, and care and restraint during the first 1,000 miles will be handsomely repaid.

Change the engine oil after the first 500 miles, and every 1,500 miles thereafter.

SECTION I.

General Driving and Maintenance.

Preliminary.—Before a car may be driven on a public highway it must be registered and licensed by the local registration authority and the tax must be paid—this, for the 8/33 h.p. M.G. Midget, is £8 per annum. It is also compulsory to have the car covered by an insurance policy against third party claims. These details will usually be attended to by the agent from whom the car is purchased. In addition, every person who drives a motor vehicle must, whether the owner or not, be in possession of a driving licence. These must always be carried when on the road. Non-possession of a driving licence, besides laying the offender open to police prosecution, usually invalidates any insurance policy covering the car.

The desirability of covering the car by a good comprehensive policy in addition to the third party insurance, cannot be over-estimated, and this should cover accident, theft and fire. The agent who supplies the car will always be in a position to give sound advice on insurance matters, and most M.G. agents are also agents for first-class insurance companies. The policy should cover remote contingencies as well as the obvious ones mentioned above; to sacrifice any benefits to save a few shillings on the annual premium is the worst possible example of “penny wise, pound foolish.”

Petrol.—The petrol tank, which holds $4\frac{1}{2}$ gallons, is carried in the dash, and the filler is under the bonnet on the off side. The petrol tap, which is under the scuttle, is reached from inside the car. It is of the ‘two-way’ type, plainly marked main and reserve.

We do not recommend any particular brand of petrol in preference to all others, any good No. 1 spirit or benzole

THE M.G. MIDGET MANUAL

mixture being suitable. The owner will soon find by experience which gives the best results, and will learn to avoid fuels which give difficult starting or cause "pinking" of the engine.

Oil.—Filling up with oil, and lubrication generally, is dealt with in Section II.

Water.—The water level in the radiator should be inspected regularly, and kept well up. Unless the cylinder outlet pipe is covered, the thermo syphon circulation will be destroyed, with consequent overheating and possibly serious damage.

It is advisable occasionally to drain off all the water (there is a tap for this purpose at the bottom of the radiator, under the bonnet) and swill out the whole system, refilling again with clean water. The ideal is always to use rain or distilled water, but this is seldom practicable, and any clean drinking water is quite suitable. This should be a soft water if possible, as hard water tends to form a "fur" inside the system just as in household kettles and other utensils, and this "fur" will in time decrease the cooling efficiency.

The radiator should be emptied in hard, frosty weather to prevent the water becoming frozen, in which event there is a grave danger of the water jacket surrounding the cylinders being cracked. To avoid this necessity a good plan is to fill the radiator with a mixture of water and commercial glycerine in the proportion of three of the former to one of the latter. This mixture is proof against freezing down to 10° F. below freezing point. This is far cheaper than buying special anti-freezing compounds and does not affect the efficiency of the radiator.

Cleaning.—A good car deserves to be kept clean, and regular attention, besides keeping up the appearance, will lengthen considerably the life of the paintwork, upholstery and such of the mechanical parts (axles, wheels, etc.) as are exposed to mud and water. The cellulose and fabric finish, which is standard on M.G. Midget cars, will keep its good looks in face of neglect which would rapidly ruin the old type of paintwork and varnish, but even so it should be given regular care if it is to keep its pristine appearance for a long period.

GENERAL DRIVING AND MAINTENANCE

A car should always be washed with *plenty of water*, mud and dust being swilled off by the water and not rubbed off with the cleaning materials. A hose is of course the ideal, but if this is not available a large bucket may be employed, the water being changed frequently. It should always be remembered that road dirt contains a large percentage of hard grit which will scratch the surface of the cellulose when *rubbed*. off. It is a feature of cellulose paint that dirt and dust may be brushed off dry without spoiling the appearance, good cellulose being if anything improved by "grit polishing." Nevertheless, every dry rub down inevitably takes some of the cellulose away with the dust, and the careful owner will obtain longer life from his cellulose finish if he takes a little extra trouble and washes it thoroughly. Washing off mud while still wet will effect a considerable saving of time and trouble.

A stiff spoke brush is very useful for getting into the nooks and corners of the axles and brake gear (all of which should be washed as often as the body), and it is important to clean carefully the wire wheels, remembering that neglect of the steel spokes may allow the ingress of rust, which will in time weaken the structure of the whole wheel. If the wheels are removed to facilitate washing, care must be exercised to avoid entry of water into the wheel bearings and hub caps. Also be sure the wheel nuts are properly retightened.

Fabric Bodies.—The above remarks apply, in general, to all types of coachwork, but there are one two special points worth noting in connection with fabric bodies. When washing the best results are obtained by using warm (not very hot) water, and soft soap applied by a soft brush, avoiding a strong caustic soap. Should the fabric be accidentally torn or cut, the hole should be closed with ordinary sealing wax to prevent ingress of dirt and water—sealing wax can be obtained in any colour, and if chosen to match the fabric and carefully applied and smoothed down will make a sound and almost invisible repair. If the hole is too big to seal in this manner it should be either patched as soon as possible with a suitable piece of fabric or a new panel fitted. The ease and cheapness with which the latter can be done is one of the great advantages of this type of body.

Wheels and Tyres.—Correct inflation of tyres is very im-

THE M.G. MIDGET MANUAL

portant both for preserving the tyres themselves and also for ensuring maximum driving comfort, steering and road holding. Correct pressures for the M.G. Midget are :

Front, 24lbs. Rear, 28lbs.

Pressures should be checked not less frequently than every week or five hundred miles, using a reliable gauge for this purpose, as it is quite impossible to judge by feel or appearance. The spare wheel tyre should be checked regularly with the others.

A wheel should always be changed immediately if the tyre is punctured, and although this is a very simple matter the following hints are worth remembering.

Always make sure the hand brake is firmly on before jacking up, and if a wheel change has to be made on a hill chock the wheels as well. Take care that no dirt gets into the hubs or hub caps.

When tightening up the hub nuts, give each one a quarter of a turn at a time to make certain the wheel is true; do not do up one dead tight before starting the others.

A punctured tyre should be repaired, preferably vulcanised, as soon as possible. Owners who wish to repair their own punctures will find tyres very easy to remove if the directions under the adjoining sketch are carefully followed.

Valve Cap.—The valve cap fitted to each valve provides an additional air seal and prevents the ingress of dirt into the valve interior. Beneath its rubber cover the tapered end of the cap will be found to be slotted. This slot is in effect a key which, when inserted into the mouth of the valve, can be engaged with the valve interior for the purpose of unscrewing it.

Valve Interior.—The airtightness of the valve depends upon the proper functioning of its "interior." It may be tested for airtightness by rotating the wheel until the valve is at the top and inserting its end in an egg-cupful of water. If bubbles appear, in spite of the fact that the valve interior has been well screwed down, it is evidence that its seating is faulty. It should be removed and replaced by a new interior. It is advisable always to have spare interiors handy, and these are procurable suitably packed in small metal containers.

GENERAL DRIVING AND MAINTENANCE

INSTRUCTIONS FOR REMOVING TYRES.

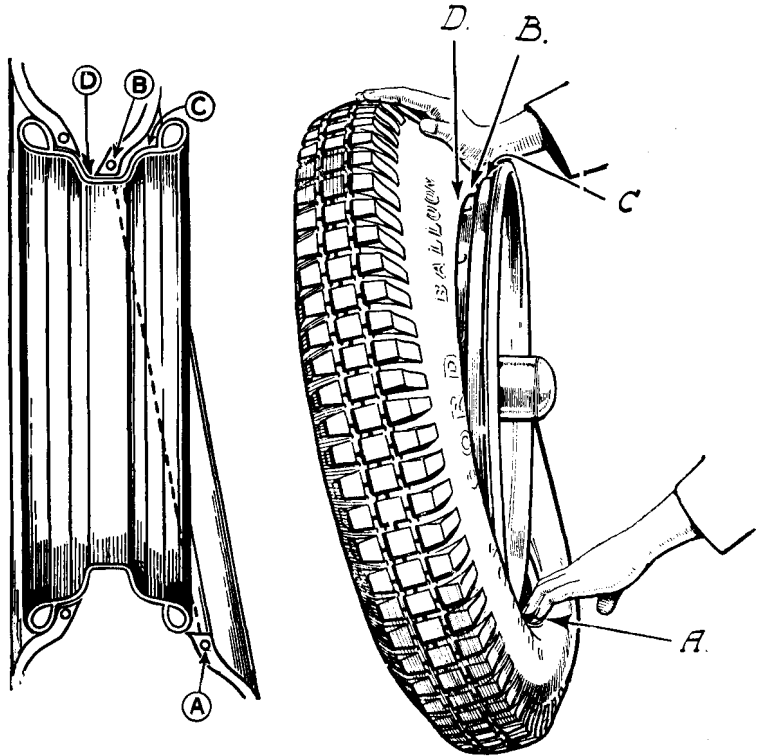

A tyre and rim in section, showing on the left the two wired edges of the tyre in position on the shoulders of the rim. The tyre cannot blow off, because the edges are inextensible—neither can the tyre edges be lifted by levers from the rim shoulders from the rim edges. *But* by pushing both the tyre edges down off the rim shoulders into the depressed centre of the rim at "D" then the tyre edge can be easily lifted off the rim at "A." This is an easy and simple operation, and requires no force.

You cannot *pull* the tyre edge at "A" over the rim edge until the tyre edge at "B" is pushed off the rim shoulder "C" down into the well "D," then tyre edge at "A" comes over the rim easily.

Remember the tyre edges are inextensible—force will only damage the tyre and cannot stretch the edge.

THE M.G. MIDGET MANUAL

The hexagon rim nut should be kept tightly screwed up on to the rim. This nut, in addition to holding the valve in position on the rim, forms a water seal preventing the entry of water through the valve opening.

Starting.—The M.G. Midget is normally a very easy starter, and the starting motor will be found quite efficient even in the coldest weather unless the battery has been neglected and allowed to run down (see Section VI). Much strain, and consequent wear, will be saved however if, in very cold weather, the engine is given a few turns by hand before using the starter. This is best done with the engine switched off, and the mixture control on the near (left) side of the dash in the “rich” position—that is, pushed right in. There is a detachable starting handle included in the tool kit, and before using it it is necessary to remove the fairing which covers the front dumb irons, secured by the two milled nuts at the front. This “easing” by hand frees the thick cold oil which “gums up” the pistons and bearings, and also draws a rich mixture into the cylinder.

As soon as the engine starts the mixture should be gradually weakened (i.e. the control on the near side of the dash pulled out). A light return spring is fitted to the mixture control so that it returns to the normal running position. To run with an excessively rich mixture is wasteful of fuel, and is extremely bad for the engine, as the surplus petrol tends to condense on the cylinder walls, washing away vital lubricant.

Few people realise how much damage can be done to an engine during the first minute by careless handling especially in cold weather. Many owners race their engines as soon as they start, to warm them up and “get them going”; this is very bad for an engine, as the oil is cold and thick, and has probably partially drained away from the bearings and cylinder walls during the night. A moderate speed is vitally necessary for a time, to give the oil time to start circulating.

On the other hand, *too* slow an initial speed is also bad, as the cylinder walls are lubricated by “spray”—that is, by surplus oil thrown out by the connecting rod bearings as they rotate—and when an engine is run very slowly indeed there

GENERAL DRIVING AND MAINTENANCE

may not be sufficient of this spray adequately to feed the cylinder walls and pistons especially when the oil is cold and thick.

The ideal is to let the engine run for a full minute, or longer if possible, at about 1000 r.p.m. in neutral. This is equivalent to about 16—17 m.p.h. on top gear, and is readily judged by ear.

These remarks on excessively *slow* running apply to a lesser degree when the engine is warm, and the owner should see that his normal slow running speed is not cut down to too fine a limit as there is always then the tendency for a sparking plug to 'soot up' and cease to fire. Immediately this happens the piston will begin pumping oil which will get on to the plug and prevent it firing when the speed is subsequently increased. Nearly all cases of 'oiling up' of plugs are due to this cause.

In very cold weather a car left in an unheated garage may be badly damaged by freezing water cracking the radiator or cylinder block, and precautions must be taken to avoid this. The radiator may be drained off when the car is put away, refilling (best with hot water) before being used again, or some type of safety heating lamp placed under the bonnet, which should also be covered with a rug. The adoption of some simple heating device will ensure an easy start in the morning as well as removing all risk of freezing. See note on page 2 regarding the use of glycerine.

Gear Changing.—The sweet clutch and well-designed gear-box of the M.G. make silent gear changes a simple matter, and every owner should endeavour to become expert in an art which will enable him to get the very best performance and pleasure from his car. Although the M.G. engine will pull gamely on hills down to very low speeds on top gear, faster and better climbs will be made by changing down to second at not less than 30 m.p.h. and to bottom (if a really steep hill demands it) at not less than 15 m.p.h. Similarly in picking up, the changes from first to second and from second to top should be made at about 15 m.p.h. and 30 m.p.h. respectively if full advantage is to be taken of the really exceptional acceleration of which the car is capable.

The driver who makes full use of his gears when slowed

THE M.G. MIDGET MANUAL

by corners or other traffic will always put up a very much better average than the "top gear man," and under modern crowded road conditions the intermediate gears of the M.G. are of real value when intelligently used.

The essential secret, if it can be so called, of successful gear changing is the ability to judge engine speed against road speed on any gear, and once the driver has mastered this he will be able to make perfect and silent gear changes at any speeds which engine r.p.m. allow. It is, for instance, occasionally useful for a quick get-away to be able to change straight from top to bottom at 5-10 m.p.h. when slowed by bad corners or traffic, or to coast downhill in neutral and get into gear again at 30, 40 or 50 m.p.h. at the bottom; these and other refinements are not "stunts" at all, but simply the result of a real understanding of one's engine and gearbox.

Changing Up.—The change-up on the M.G. Midget is very simple, and is best performed without double de-clutching, thus :—

Release accelerator first, then declutch, at the same time moving gear lever into neutral.

Pause for a moment or two in neutral.

Move gear lever into higher gear position, and let in clutch and accelerate.

When changing up on the M.G. the engine speed has to drop to just about half what it was on the lower gear, and the pause in neutral is made to allow for this. The exact length of the pause is dependent upon the speed at which the change is made; for example, when changing up from second to top a longer pause is required at 30 m.p.h. than at 20 m.p.h. Even at higher speeds, however, the pause is very short, and at low speeds, say from bottom to second at 6-7 m.p.h. or from second to top at 14-16 m.p.h. the change practically "straight through."

To make a good change-down on the M.G. it is essential to double declutch except at the very lowest speeds. The change-down differs from the change-up in that the engine speed has to be approximately *doubled* instead of *halved*, thus :—

GENERAL DRIVING AND MAINTENANCE

Changing Down.—Declutch and take foot off accelerator.

Move gear lever into neutral.

Let in clutch and give accelerator a tap sufficient to raise the engine speed to double what it was at the beginning of the change.

Declutch and move lever into lower gear position.

Let in clutch and accelerate.

When the driver is familiar with the controls a really fast change-down when ascending hills (say, from top to second at 35 m.p.h. or second to bottom at 20 m.p.h.) can be made as follows :—

Assuming engine to be pulling on full throttle on the higher gear, *keep accelerator hard down*, and

1. Declutch and move gear into neutral.
2. Let in clutch.
3. Declutch and move lever into lower gear position.
4. Let in clutch.

As keeping the accelerator hard down causes the engine to pick up very rapidly, it is *essential* that the clutch and gear movements be made as quickly as possible. Changing down on full throttle in this way requires a good deal of practice, and can only be done at fairly high speeds, but for a fast climb of a steep hill it is ideal, as the loss of road speed during the change is virtually nil.

The First Thousand Miles.—The various chapters of this Manual cover in full the general maintenance of the M.G. Midget, but for the first thousand miles or so it needs especial care; the final performance and length of life of a car depend entirely on the treatment it receives when it is new, and a little trouble and restraint will never be regretted. We strongly recommend that for its first five hundred miles at least, and preferably its first thousand, the engine be treated gently, not exceeding about 35 m.p.h. as a normal cruising speed, and making 10 and 20 m.p.h. the limits on first and second gears respectively with only occasional bursts at higher speeds.

Most motorists to-day realise the importance of slow running at first, but comparatively few understand that what

THE M.G. MIDGET MANUAL

really matters is not so much engine speed as the *load* or amount of work the engine is doing. It is, for instance, obvious that an engine pulling hard up a stiff hill on full throttle at 20 to 25 m.p.h. is working much harder than when it is running easily along the level on a slight throttle opening at 35 to 40 m.p.h. The running-in rules ought therefore to include "not more than a third throttle" as well as "not more than 35 m.p.h.," changing down on hills and cruising up easily at 18 to 20 m.p.h. on second gear rather than pulling hard on top at 30 m.p.h.

Attention must be paid to the following points:—

1. Check oil level in engine sump every 100 miles and keep well up to the "full" mark. It is important, however, not to overfill the sump with oil as this naturally tends to oil up the plugs.
2. Check oil level in gearbox and back axle after 500 miles and fill up if necessary.
3. Lubricate chassis freely and frequently as described in Section II, not overlooking the clutch spigot bearing and clutch splines.
4. After 500 miles check the following:
 - Valve rocker clearance (Section III).
 - Wheel Stud Nuts for tightness.
 - Cylinder Head Nuts (Section III).
 - Bolts holding body to chassis.
 - Nuts holding engine in frame.

A little engine oil mixed with the petrol assists running in; it should be mixed in the proportion of a quarter of a pint of oil to a gallon of petrol *before* filling the tank and not poured loose into the latter.

On the completion of 1000 miles the following operations should be carried out, as described elsewhere in this Manual. Regular M.G. agents carry out this work free of charge as part of the After-Sales Service benefits extended to all purchasers of M.G. cars.

Drain sump, gearbox and back axle, and refill. (New oil chargeable to customer.)

GENERAL DRIVING AND MAINTENANCE

Oil and grease car throughout once. (New lubricant chargeable to customer.)

Check and (if necessary) correct ignition timing and tappet clearances, and clean plugs.

Check and (if necessary) correct carburetter control gear.

Adjust brakes.

Look over car and (if necessary) correct tightness of all exposed nuts, particularly those on spring clips, steering gearbox bracket and body bolts.

Pull down cylinder head nuts.

Check and (if necessary) correct clearance for clutch-pedal in footboard.

THE M.G. MIDGET MANUAL

MISCELLANEOUS DRIVING HINTS.

- Do** use the gears freely, particularly on hills and when accelerating after corners, in traffic, etc.
- Do** free the engine by hand when cold before using the starter.
- Do** avoid "harsh" driving, particularly when braking; the M.G. brakes are smooth and powerful and need never be "stamped on."
- Do** retard the ignition before starting the engine.
- Do** read this Manual thoroughly and carefully and follow out the instructions laid down.
- Do** write to us or come and see us (by appointment, please) when in any difficulty.
- Do** always quote model, year, engine and chassis numbers when writing. This is very important.
- Do not** allow the engine to "pink."
- Do not** slip the clutch except when actually starting off or changing gear; change down in traffic, to bottom gear if necessary.
- Do not** subject the tyres to glancing blows from the kerb when drawing up beside the pavement; this may interfere with wheel alignment and have a serious effect on steering and tyre life.
- Do not** lean on open doors.
- Do not** under any circumstances allow the oil level to fall below half full; it is best to keep it always up to three-quarters at least.
- Do not** mix different brands of oil in the sump.
- Do not** race the engine when it is cold; this will shorten considerably the life of pistons and bearings, and may even result in piston seizure.
- Do not** leave the headlamps alight when the car is stationary at night; this drains the battery unnecessarily and is very discourteous to other road users.
- Do not** try to improve your car's performance by altering the ignition timing or interfering in any way with standard settings and adjustments. The makers know best.
- Do not** forget to lubricate clutch thrust.

SECTION II.

Lubrication.

Engine.—The engine sump holds one gallon of oil and is replenished through an easily accessible filler on the off side of the engine. The oil level in the sump is quickly ascertained by means of the “dip-stick,” which is just behind the oil filler; this has two marks on it, the upper one showing the level with the sump full, while the lower one is the danger line. *To take a reading the engine should be switched off*; the dip-stick is withdrawn, wiped clean, re-inserted to its full length, withdrawn again, and then read. These precautions are necessary, as when the engine is running the oil in the sump is churned up, and splashes on the dip-stick may give a false reading.

The oil level should be inspected every day before starting out, or every 100-150 miles on a long tour, and although it need not always be absolutely full, the level should be kept well up, especially when the car is new (see Section I, page 12) and never allowed to fall lower than half-way between the “full” and “danger” marks. At the same time over-filling should be carefully avoided as this causes the oiling up of the plugs.

A gear-type pump is carried at the front of the engine and driven from an inclined shaft. The oil is filtered by a large external filter, before passing to the pump, thus ensuring the circulation of clean oil. An oil pressure gauge is provided on the instrument board to indicate the proper functioning of the pump. The actual reading on the gauge may be found to vary considerably on the same car under varying conditions. It will be found on first starting up the engine from cold that

THE M.G. MIDGET MANUAL

a reading up to 100 or so pounds per square inch will be obtained. As the engine warms up and the oil consequently becomes more fluid, this pressure will steadily drop until a reading of some sixty pounds only is registered. It must be understood that so long as a pressure somewhere in the neighbourhood of this figure when running fast is registered on the dial it is an indication that the pump is functioning correctly.

N.B.—There is no connection between the pressure indicated by the gauge and the oil level in the sump. The latter must always be checked by mean of the dip-stick as described above.

The lubricating pump draws its supply of oil from the bottom of the sump through a large diameter suction pipe and the external filter delivering oil at high pressure into an internal oil duct, which runs across to the off-side of the engine, where it feeds into the forward end of another internal duct running to the rear crankshaft bearing. Oil grooves in this bearing and drilled passages in the crankshaft conduct the oil to each big-end. These are in consequence fed with oil under high pressure. An external duct from the pump delivery duct extends vertically to the cylinder head, where it encounters a restrictor pin. This pin is for the purpose of regulating the oil fed to the overhead valve gear, and should on no account be damaged or interfered with.

Oil passing the restrictor pin enters a drilled passage in the cylinder head which registers with a similar passage drilled in the front camshaft bearing bracket, communicating with the camshaft bearing itself and each of the valve rocker shafts. The valve rocker shafts are drilled at intervals to correspond with the valve rockers, whose bushes are grooved, feeding drilled passages in the rocker-arms which lubricate the cam faces.

The rocker shafts in addition feed the rear camshaft bearing with a generous supply of oil, and a duct in the forward camshaft bearing impinges a constant stream of oil on the camshaft drive gears. Surplus oil from the valve gear finds its way back to the engine sump down a drain passage and external pipe at the rear of the cylinder block, and by a similar drain passage and pipe into the auxiliary drive cover at the forward end of

LUBRICATION

the crankshaft, where it lubricates the dynamo drive and inclined shaft gears, finally passing through the crankshaft ball race on to the oil filter in the crankcase.

Draining the Sump.—Owing to dilution by petrol, a certain amount of which always works past the pistons into the sump, and chemical decomposition caused by heat, the best oil gradually loses its lubricating properties, and must therefore be periodically drained out and renewed. This should be done at least every 1500 miles, and preferably every 1000; it is false economy, particularly in a small high speed engine like the M.G. Midget, to run with old "worn out" oil.

To drain the oil, the following procedure is adopted. Underneath the engine assembly three plugs will be found. These, reading in order from the front of the car, are for draining the engine sump, the clutch housing, and the gearbox. Unscrewing the sump plug will drain the oil from the sump. We do *not* recommend that paraffin should be swilled through the engine or that the engine should be run without oil in the sump with the plug removed. The oil-filler for refilling will, as before stated, be found on the off-side under the bonnet, and the filler for the gearbox is on the near-side of the gearbox casing. Occasionally the second drain plug from the front of the power unit may with advantage be removed to drain off any oil which has found its way into the clutch compartment. When the sump has been drained approximately one gallon of oil is required to fill it. After refilling the sump it is necessary to prime the oil pump by filling with oil the large external filter which is situated on the opposite side of the engine to the oil filler. Care must be taken to screw the filter cover on tightly before starting the engine (see "External Oil Filter" below).

About every 5000 miles it is advisable to remove the sump completely, to enable it to be thoroughly cleaned. After draining the oil as described above, proceed to remove the screws attaching the oil sump to the bottom of the cylinder block, and the union connecting the oil suction pipe at the front of the sump, when the oil filter may be withdrawn.

External Oil Filter.—At the end of the first 100 miles and every subsequent 500 miles the gauze cylinder should be removed from the external oil filter and thoroughly cleaned in paraffin (see illustration). After cleaning, the filter

THE M.G. MIDGET MANUAL

should be filled with clean oil and care should be taken to screw the filter cover on tightly before starting the engine. On no account introduce paraffin into the filter, and never clean or dry off with rag or cloth—just wash clean.

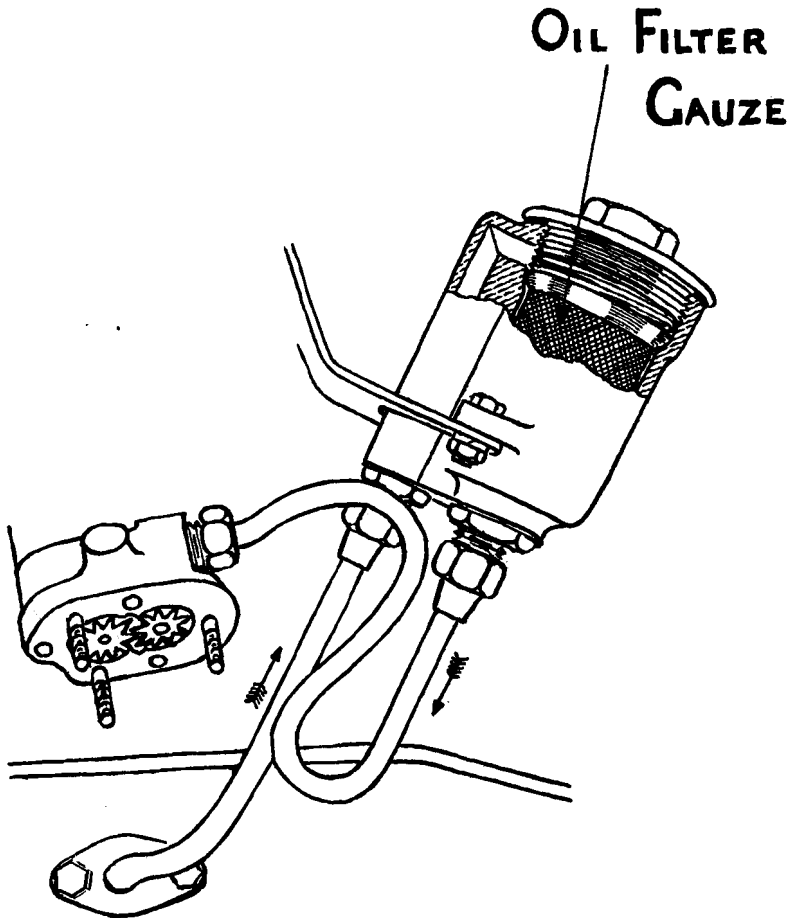

The gear type oilpump with its cover removed and body partly broken away to show the oil relief valve. The construction of the large external oil filter is also clearly shown.

LUBRICATION

The Oil Restrictor.—At the junction of the oil delivery pipe to the cylinder head is the oil restrictor or metering pin, regulating the quantity of oil which is delivered to the overhead valve gear. At the end of the first 100 miles and every subsequent 500 miles this restrictor pin should be withdrawn by passing a piece of stiff wire, hooked at its end, through the hole which can be seen in the end of the pin. The restrictor and its housing should be carefully cleaned before replacement. On no account file the pin, alter its shape or otherwise interfere with it.

Should the oil gauge suddenly show a steady rise in pressure when the engine is hot, it is an indication that the restrictor is choked and requires immediate cleaning.

RESTRICTOR PIN COVER

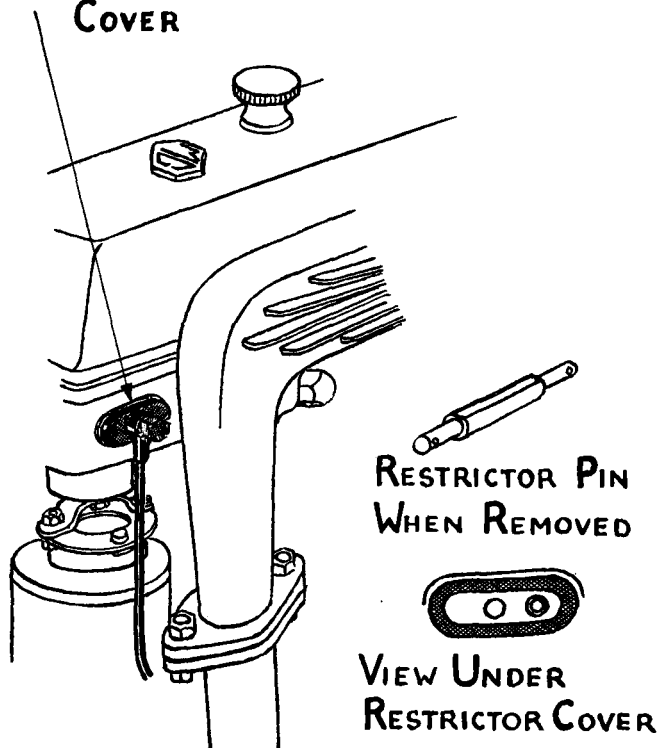

The oil restrictor pin is here shown withdrawn from its housing in the cylinder head. It is imperative that it should be kept absolutely clean.

THE M.G. MIDGET MANUAL

Clutch Thrust.—Access to this is obtained by removing the cover plate on the clutch housing, when the lubricator will be found underneath. A few drops of oil should be dropped in every 500 miles.

Gearbox and Back Axle.—The oil level in the gearbox and in the back axle should be inspected every 500 miles and replenished if necessary through the combined inspection and filler caps, situated, in the case of the gearbox, on the near side, and in the case of the back axle, on the rear of the differential housing.

The gearbox and back axle should always be filled up when warm—i.e. immediately after a run—and a short stick should be inserted into the filling orifices to make sure that congested oil clinging inside the spout does not give a false level reading.

Overfilling must be avoided, because excess of oil in the gearbox may work through to the clutch and cause serious slipping, while excess in the back axle may work along to the brakes and seriously impair their efficiency. There is no danger of this if the fillers are correctly used, because their positions on the gearbox and axle housings determine the "full" level automatically.

The gearbox and back axle should be drained after the first 1000 miles (see Section I), and subsequently every 3000-4000 miles. When refilling the gearbox requires one pint of oil, and the back axle one and a half pints. The drain plugs will be found at the bottoms of the housings, and it easiest to drain immediately after a run when the oil is warm and flows freely.

The Ignition Distributor.—Every 1000 miles the distributor cover should be removed and one or two drops of good quality thin oil placed on the felt pad revealed below the rotating arm when it is withdrawn.

Chassis Generally.—All points on the chassis which require regular lubrication are fitted with Enots nipples, and an "Autolub" oilgun is included in the tool-kit. This gun should be filled with gear oil by unscrewing the large cap on the end of the container and removing the automatic feed plunger by pulling on the chain attached to it. When the gun is sufficiently full of oil, the plunger and end cap should be replaced. Removal of the brass cover on the other end

LUBRICATION

of the gun displays an extension piece with a strong recoil spring surrounding it. This extension is really a type of high-pressure pump, and it has at its end a recess with a hole in the centre. By applying this recess to the projection presented by a nipple and pushing the whole of the pump inwards, oil will be forced under pressure into the nipple, and as soon as pressure is removed from the oilgun the extension will be forced out again by its return spring, and the vacuum created will cause the automatic plunger to take up a new position ready for delivery of the next charge. This gun is particularly easy to handle and extremely effective in action. After using the gun replace the brass cap over the extension, screwing it up reasonably tightly. This will prevent leakage of the oil from the gun while it is not in use.

Enots nipples are fitted at the following points:—

- 6 on front spring shackles.
- 6 on rear spring shackles.
- 4 on front axle steering knuckles.
- 2 on steering track rod.
- 2 on steering drag link.
- 4 on brake camshaft bearings.
- 1 on steering gearbox.
- 1 on steering column.
- 2 on brake cross shaft.
- 1 on brake pedal fulcrum.

The chassis of the Sportsman's Coupé is fitted with a semi-group lubrication system. From the Master Nipple or central lubricator small brass pipes connect up all points in series, the small brass pipes ending at the bearing in an adjustable and calibrated Feed Plug. As this does not include all lubrication points the chart at the end of the book should be consulted.

It will be seen, therefore, that the lubricant is forced along the pipe from the Master Nipple and arriving at the Feed Plug, the predetermined amount penetrates into the bearing through the adjustable valve, the remainder travelling on to the next bearing. The valve in the Feed Plug is calibrated before the car leaves the works to deliver the requisite amount required by any particular bearing. As, however, the requirements of two similar bearings are sometimes found to differ in practice, an adjustment of the valve is provided.

THE M.G. MIDGET MANUAL

To Adjust Valve.—The Feed Plug is closed by a small sealing screw. Remove this screw and with a small screw-driver slacken off or tighten up the valve found below the screw according to requirements. A quarter turn either way is the maximum range of adjustment which should ever be required unless the valve has been choked with foreign matter from the lubricating gun. In this case remove the valve from the bearing, clean and replace.

Upkeep Instructions.—Use Tecaletmit Solidified Oil or clean gear oil in the gun. Tecaletmit "Goldengear" Heavy is very suitable. Wipe the Master Nipple and the nozzle of the gun with a rag before connecting. Use gun until lubricant is seen to be issuing from all bearings.

It is difficult to say definitely how often chassis lubrication is required, as this depends entirely upon the conditions under which the car is used. It should be done at least every 500 miles and not less often than every fortnight, irrespective of mileage, and more frequently if the weather is wet and muddy. The "maintenance summary" at the end of this Manual indicates the minimum of oiling required under normal conditions, and the owner must use his own discretion as to whether particular circumstances necessitate more frequent attention.

The oilgun should be applied to each nipple in turn and given three or four strokes. If at any time it is found that a nipple will not pass oil at all, or does not retain it, it should be unscrewed and washed with paraffin, as it is probably choked. If this does not effect a cure a new nipple should be fitted.

Note.—The nipple on the shackle at the front end of each rear spring is on the inside, and is reached, on removing the seat, through the openings provided.

Important.—The oilgun should always be filled with gear oil, not grease.

Wheel Hubs.—The wheel hubs should be kept well greased in order to guard against the formation of rust. Every 1000 miles the front wheels should be removed and the hub caps replenished with thin grease. Replacement of the wheel will force this grease through the passage ways drilled in the axle nut washer and thus lubricate the ball race. Care should be

LUBRICATION

taken not to overdo this filling. When the car is in use the grease gradually warms up, and expands, and sufficient pressure may be generated to force this grease past the felt retaining washer, at the inner end of the hubs, into the brake-drums. It is advisable, before finally screwing on the wheel stud nuts, again to withdraw the wheel and empty a portion of the grease remaining within the hub.

Every 1000 miles the rear wheels should be removed, the Enots oilgun applied to the nipple on the end of the axle flange and given two strokes.

The oilcan which is provided in the tool kit should be used regularly on all brake-rod shackles, adjustments, etc., and at points on the accelerator and other controlling rods and pins where friction may occur. A few drops of oil given occasionally to the bonnet hinges, door catches and hinges, and other points where friction occurs will prevent trouble from these points caused by stiffness or rust. It is especially advisable to use the oil can regularly on the brake rod guides, which steady the rods, and will be found about half-way between the brake cross shaft and the wheels. Ordinary engine oil may be used in the oil can.

Brands of Oil.—The following grades of oil are approved for use in the M.G. Midget.

Engine.

Duckham's Adcol N.P.2 (winter).
Duckham's Adcol N.P.3/4 (summer).
Filtrate Medium (winter).
Filtrate Extra Heavy (summer).
Mobiloil "A" (winter).
Mobiloil "BB" (summer).
Triple Shell (summer and winter).
Speedolene "B."

Gearbox, Back Axle, Chassis Generally.

Duckham's Gear Oil "N."
Filtrate Gear Oil.
Price's Motorine Amber "B."
Shell Gear Oil.
Speedolene "H."
Vacuum "C."

THE M.G. MIDGET MANUAL

We do not recommend the mixing of oils of different makes in the sump; that is to say, if an engine has been filled with one of the above-mentioned oils and it requires replenishment during the course of a run, the same make of oil should be used for replenishment if at all possible.

It should be particularly remembered that it is dangerous to mix a mineral oil with a vegetable oil having a castor oil basis. If it is desired to change from one brand to another, this change should only be made by draining the sump and refilling with new oil.

It is also inadvisable to mix any compound oil (i.e. any one made from vegetable, animal and mineral oils) with another of the same type or with a straight mineral oil.

SECTION III.

Adjustments.

A number of adjustments periodically required by the M.G. Midget can be carried out by the average owner driver, and these are briefly described below. Separate chapters are devoted to the carburettor and electrical systems.

VALVE TIMING CHART.

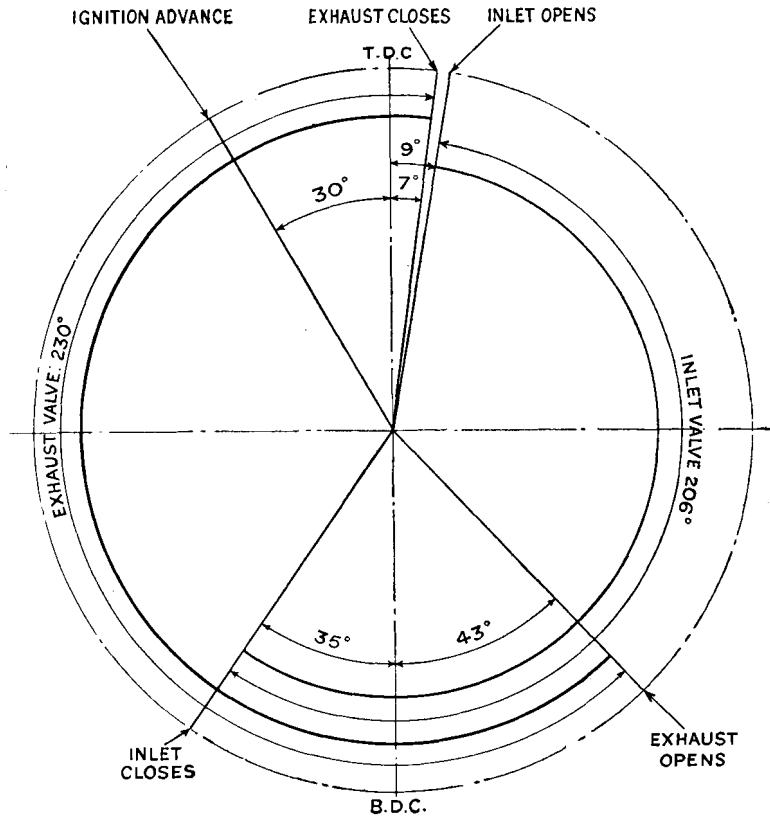

THE M.G. MIDGET MANUAL

Engine.—Decarbonising is the chief attention which the engine requires. It is impossible to lay down a definite time or mileage at which this will become necessary, as it depends on so many factors—the age of the engine, the way it is driven, and a hundred and one other things. With the present day advanced designs and high quality lubricating oils, engines may run for a five figure mileage without demanding attention, but we strongly recommend that the cylinder head be lifted not less often than every 5000 miles. The chief reasons for this are that it enables the valves to receive regular attention, avoiding excessive pitting and burning, and also that maximum performance is maintained.

A new engine should be decarbonised after the first 1000 miles (see Section I, page 12).

In addition to the standard tool kit, the following should be at hand before starting operations :—

Spare cylinder head gasket.

Valve grinding paste—this can be purchased ready mixed, and it is best to have two grades—medium and fine.

Castille soap, or some good proprietary jointing compound.

A shallow basin (such as a baking tin) to form a paraffin bath for the “ bits.”

Dismantling.—Open the radiator drain tap, and while the water is draining off, proceed to :—

Remove bonnet altogether.

Turn petrol tap off.

Detach sparking plug cables—these are all of different lengths so that there is no fear of confusion when re-assembling.

Remove valve gear cover; and do not mistake the “ M.G.” breathers at either end for nuts! They cannot be unscrewed, and need not be touched.

Attention may now be turned to the exhaust and inlet manifolds, which must be removed, after uncoupling the petrol pipe, throttle and mixture controls from the carburettor, and the exhaust pipe from its manifold. The

ADJUSTMENTS

carburettor need not be detached from the induction manifold—the two should be removed en bloc from the cylinder head. Apart from the uncoupling of the exhaust pipe, petrol pipe, etc., it is only necessary to remove the four retaining nuts to enable both manifolds to be lifted clear.

After removal of the manifolds, dismantling may be continued as follows:—

Uncouple the oil delivery pipe from the cylinder head (near side forward, see Section II) by unscrewing the single retaining bolt, and withdraw the oil restrictor, to avoid risk of loss when the head is subsequently removed.

Uncouple the oil return pipe at the *front* of the engine by unscrewing the two nuts only—it need not be withdrawn from its studs as it will draw straight off when the head is lifted.

Remove bodily the oil return pipe at the *rear* of the engine by unscrewing the retaining nuts at top and bottom, taking care not to lose the washers.

Release top water connection by removing the two attachment bolts, taking care not to lose the washer.

Between the projecting portion of the cylinder head block and the dynamo will be found a circular flexible coupling. Remove the two bolts which attach it to the dynamo drive yoke. This will permit the flexible coupling to be withdrawn with the cylinder head.

The cylinder head is held on to the cylinder block by ten nuts screwed on to the long studs passing through the cylinder head. Slacken off these nuts in rotation, half a turn at a time, until they are quite loose, then finally remove them. It is unwise to unscrew any one of these nuts completely before slackening off the remainder, as this will impose uneven stress upon the cylinder head, leading to its distortion.

The cylinder head is now ready to be lifted from the cylinder block. The breaking of the joint between the two will be facilitated by smartly tapping the sides of the head with a wooden mallet or with a hammer with a piece of wood interposed to take the blow. The joint may, however, not break freely, in which case it is permissible to insert a screw-

THE M.G. MIDGET MANUAL

driver or similar blunt wedge-shaped tool between the joint at the two places—one on either side of the engine—where the cylinder head gasket has been cut away for the purpose. Do not insert the screwdriver too far. It should on no account be forced against the gasket, which would become damaged as a result. When the joint is broken no difficulty should be experienced in lifting the head clear of the studs providing it is withdrawn squarely. Place the head on a bench out of harm's way, and carefully lift the copper asbestos gasket straight off the cylinder head studs, keeping it parallel with the upper face of the cylinder head block and taking particular care that it is not bent or otherwise damaged in the process.

Decarbonising.—Everything is now in readiness for decarbonising the piston crowns and the surrounding face of the cylinder block. Turn the engine by the starting handle until any two pistons are at the top of their travel, when it will be found that the remaining two are at the bottom of their cylinders. Stuff the open ends of these cylinders with clean rag, and with an old screwdriver, or some blunt tool, scrape the black deposit off the top of the cylinders and the face of the cylinder block adjacent to the cylinder bores. With a clean rag damped with paraffin clean off every trace of foreign matter remaining, but do *not* attempt to polish things up with emery cloth or other abrasive, or you will do far more harm than good. When these two pistons have been properly cleaned give the starting handle half a turn and clean the other two in the same way.

Attention should now be given to the cylinder head. Remove the sparking plugs and turn the head upside down, thus exposing the combustion chambers, in each of which will be observed the circular heads of two valves—one inlet and one exhaust.

With a blunt screwdriver carefully scrape away the carbon deposit adhering to the surface of the combustion spaces, taking particular care to go round each valve with a small screwdriver in order to remove all trace of carbon. Clean the combustion chambers and valve heads carefully with rag moistened with paraffin.

Removing the Valves.—Having thoroughly cleaned the combustion spaces and valve heads, place the cylinder head

ADJUSTMENTS

on the bench the right way up. To obtain access to the valve springs, it is necessary to remove the camshaft. This is easily achieved by unscrewing the four nuts holding the camshaft bearing caps in position. These should be given half a turn in rotation, in a similar manner to the cylinder head retaining nuts, until they are eventually removed. The camshaft can then be lifted from its bearings and removed by passing it through the valve cover saddles. Removal of the camshaft enables all the valve rocker-arms to be swung clear of the valves.

A small wood block slightly thicker than the depth of the combustion spaces and an easy fit within them should now be prepared. Slip this block into the combustion space so that the valve heads are resting upon it, in order that the valve spring can be compressed with the special valve tool previously described, without forcing the valves open. Depression of the springs will expose two small conical cotters engaging in a groove in the pencil-like end of the valve stem. Removal of the cotters will release the valve spring cap from the valve stem, permitting its removal and releasing the valve spring. When the springs of both valves have been removed, the head may be raised from the bench and the wood block withdrawn, thus allowing the valves to be drawn from their guides. Repeat this operation on the remaining valves until they are all removed.

Grinding-in the Valves.—Examination of the valves will show that the edges of their mushroom-like heads are bevelled off at an angle to correspond with the similar bevelled edges of the valve ports in the cylinder head and thus provide a gastight joint when they are in contact. Obviously, gastightness is not attained if these bevelled surfaces are dirty or "pitted," and in order to clean them up so that they make perfect contact over the whole of their surfaces it is necessary to grind them in. When grinding-in the valves the utmost care should be taken to see that they are inserted into the correct port. Each valve is clearly numbered on its head, and on the lower face of the cylinder head adjacent to the valve port will be found its corresponding number.

The grinding-in process consists in coating the bevelled face of the valve with a small quantity of valve-grinding paste—applied on the end of a match-stick—reinserting the valve

THE M.G. MIDGET MANUAL

in its guide and partially rotating it backwards and forwards on its seating by means of a screwdriver. Here we come to the secret of good valve grinding. The valve should be raised from its seating every few reciprocations and given a half turn in order that the grinding compound may spread itself evenly over the whole surface. If this is not done there is the possibility that minute circular grooves will be cut into the face of both the valve and its seating, which will absolutely prevent one from obtaining a good gastight fit. Probably the most convenient way of carrying out this periodical lifting is to obtain a light coil spring (similar to the valve spring but much lighter), and insert it into the valve port beneath the valve head. When pressure is released on the screwdriver the valve will pop up, when it can easily be rotated into a fresh position.

It is not necessary to continue grinding the valves once the faces of both valve and seating have assumed a clean, even, matt-surfaced appearance. A polished surface must not be expected and is quite unnecessary. If the engine has been run for a long period without being decarbonised, the valve may be badly "pitted"—that is to say, it will have a number of small black spots or depressions on its face. Should these depressions be at all excessive or deep, it is best to have the valve face trued up on a special machine at a garage. This will prevent needless grinding away of the valve seating in the cylinder head—a matter of importance, as it cannot be renewed. Any valves which are distorted should immediately be replaced by new ones. To attempt to grind them in will only produce extensive damage to the seating.

After each valve is ground in it should be withdrawn and carefully washed in paraffin, and, what is equally important, the valve seating and the surrounding valve port should also thoroughly be cleaned with a rag moistened with paraffin. Do not wash out the valve ports with petrol or paraffin or some of the grinding compound will find its way into the valve guides or other working parts, and it is of the utmost importance that it should be prevented from finding its way on to any of the working surfaces of the engine, where extensive damage may be done.

Reassembling the Valves.—When you have satisfied yourself that all trace of the grinding compound has been removed,

ADJUSTMENTS

the valves may be reassembled. Care should again be taken to see that they are in their correct ports. Reassembly of the valve is not a difficult matter with the aid of the valve tool described. After inserting the valve in its guide and resting its head on the wood packing block, the valve spring may be placed in position with the valve spring cap resting on top of it. Engage the valve tool on the cap and depress the spring so as to expose very nearly the whole of the groove in the upper end of the valve stem. Insert the two conical cotters into the groove in the valve stem (small ends downwards, of course) and gradually release the spring. Make sure that the cotters are properly engaging in their grooves before dealing with the next valve. If the valve cover saddles have been removed, do not forget to replace them in position before reassembling the valves which are between the camshaft bearing brackets, or you will find that these are in the way and that you cannot replace the saddles.

Replacing the Camshaft.—Swing all the valve rockers into position against their respective valves and replace the camshaft with the two marked teeth of its bevel wheel engaging on either side of the marked tooth of the driving pinion. The camshaft bearing caps are tenoned into the bearing brackets so that there is no possibility of misalignment. Care should be exercised, however, to tighten up the camshaft bearing cap nuts evenly. Each should be given a partial turn at a time until all are perfectly tight.

Adjusting the Rockers.—In the process of grinding-in the valves a certain amount of metal is always removed. This tends to reduce the clearance existing between the head of the valve and the under-surface of the rocker-arm. It is essential for the proper functioning of the engine that this clearance should not be less than .003 in., and it is therefore necessary to check the clearance of each valve with the feeler gauge attached to one of the special rocker adjusting spanners. On one side of the rocker will be found a hexagon steel nut and on the other side a similar bronze nut. Engage the plain rocker adjusting spanner on the bronze nut and, holding it firmly in position, slacken the steel nut with the spanner having the feeler gauge. Withdrawing the spanner from the steel nut, insert the feeler gauge between the valve rocker and the cam—after seeing that the peak of the cam for that particular valve is pointing directly upwards—and rotate the

THE M.G. MIDGET MANUAL

bronze nut until the feeler gauge can just be withdrawn easily. Now, holding the spanner engaging the bronze nut exactly in this position, tighten up the steel lock nut. The clearance should then again be checked to make sure that no movement of the setting took place while the lock nut was being tightened up. When adjusting the tappits it is essential to see that the thick part of the bearing is downwards and not upwards. Then, after loosening the lock nut, the adjusting spanner should always be pressed *downwards* to reduce the clearance. If pressing the spanner downwards increases the clearance, then the eccentric is the wrong way up and requires turning around, this being done by continuing to rotate it by pressing the spanner handle *downwards* until the clearance does close.

Replacing the Cylinder Head.—When all the valve clearances have been correctly adjusted, the cylinder head is ready for replacement. It is first of all necessary thoroughly to clean the gasket and remove any carbon deposit adhering to its edges, and to coat both sides of it with an even film of Castille soap. If the gasket has been in any way damaged during the removal of the cylinder head, do not attempt to use it again, but immediately procure a new one. See that any new gasket does not burr up around the stud holes and that the cylinder bore openings are clear of the cylinder bore themselves. The gasket can then be located over the studs in the cylinder block and gently pushed into position on to the upper face of the cylinder block. It will be found convenient to use a short length of tubing (a box spanner does quite well) over the studs to push the gasket in position. This should be done very gently, taking care to keep the gasket parallel with the cylinder head and not to force one end or one side down before the other.

Turn the camshaft until the timing marks on the spiral bevel drive gears coincide, and rotate the engine by the starting handle until numbers one and four are at the very top of their stroke, with the metal electrode on the distributor rotating arm pointing towards No. 1 contact stud (No. 1 cylinder is the one nearest the radiator). This stud is easily located by tracing the high-tension lead from the sparking plug for No. 1 cylinder to its junction on the distributor cover. On removing the distributor cover the position of the metal electrode on the end of the distributor rotating arm can be seen, and its position relative to this stud noted. That the

ADJUSTMENTS

pistons are exactly at the top of their travel can be ascertained by removing the rectangular plate on the clutch housing (just in front of the gear lever), when a mark will be found on the face of the flywheel, bearing the numbers 114. This mark should be exactly in the centre of the opening in the clutch housing.

Having made sure that the pistons and camshaft are in their correct positions, the head may be lowered into position on to the cylinder block. The two holes in the flexible coupling should now coincide with those on the drive yoke of the dynamo. Replace the ten cylinder head nuts and tighten them up in the rotation indicated in the illustration, giving each a quarter of a turn at a time until all are up tight.

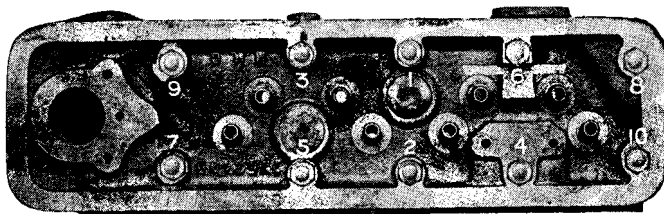

Indicating the sequence in which the cylinder head stud nuts should gradually be tightened.

The flexible coupling bolts should now be replaced, as should the oil pipes, exhaust and inlet manifolds, carburetter controls, petrol pipe, windscreen wiper tubing, sparking plugs, high-tension cables, and the valve cover. When replacing the oil pipe on the left-hand side of the head, make sure that the oil restrictor pin is in place and that it is clean.

Fill the radiator with water, start up the engine and let it idle quietly until it is thoroughly warm. Then, switching off again, remove the valve cover and go over each of the cylinder head nuts in turn, giving each a final tightening up. It will be found that now the engine is warm an extra half turn or so can be given to each nut. Do not attempt to speed up the engine until this final tightening has been effected. Start up the engine and ascertain that oil is exuding from the small oil passage drilled in each rocker-arm, and lubricating the cam surfaces. If oil is coming freely from these oil

THE M.G. MIDGET MANUAL

passages, the valve cover can be replaced, together with the bonnet, and the car is ready for the road.

About 100 miles after cylinder head replacement, it is advisable to go over the cylinder head nuts once again (when the engine is warm) to ensure that they are absolutely tight, and also to check the valve rocker clearances (see below).

Rocker Clearance.—The good tune of engines is frequently spoiled through the owner seeking silence by cutting down the rocker clearance. In order to maintain good tune over long periods it is advisable to set the rocker clearance one or even two thousandths more than the amount indicated above. *This may increase the valve gear noise but will undoubtedly lead to improved maintenance of tune over lengthy periods.*

It is particularly important to check the clearances 100 miles or so after grinding, as the valves have a tendency to "bed down," and clearances should be checked subsequently every 2000 miles.

Engine Bearings.—The mileage which may be covered before the main and big-end bearings require attention will depend entirely upon the care given to correct lubrication and the way in which the car is driven, particularly when new. Owners are not recommended to undertake this overhaul themselves, particularly when the standardised charges arrangement allows such jobs to be done cheaply and efficiently by M.G. agents all over the country.

Clutch.—The clutch is provided with two friction surfaces. The driving surfaces comprise two rings of bonded asbestos fabric, one attached to the flywheel cover-plate and the other attached to the pressure plate. Six driving pins pass through the flywheel, pressure plate and flywheel cover-plate, all of which consequently revolve together.

The driven surfaces comprise both sides of a single steel disc splined to the driven shaft. Driving pressure for the clutch is derived from six helical springs housed between the pressure plate and the flywheel.

The clutch must be run dry, and persistent slipping of the clutch is usually an indication that oil has found its way into

ADJUSTMENTS

the clutch compartment, in which case it will be necessary to remove the drain plug in the bottom of the clutch housing and drain away any oil which may be present. Oil which may then be still adhering to the surface of the clutch plates will soon be burnt away after a little use.

If the clutch is allowed to slip continuously the centre driven plate very quickly becomes excessively hot, and the heat and friction will very soon destroy the surfaces of the fabric facings.

Clutches are correctly adjusted at the Works before the car is delivered. In the early life of the car, however, a certain amount of bedding down of the friction surfaces takes place, which will permit the pressure plate to take up a position nearer the withdrawal mechanism, and thus reduce the necessary clearance between the withdrawal levers, the withdrawal race and the lever restraining springs. If this clearance is completely taken up and the withdrawal levers actually bear either against the restraining springs or against the withdrawal race, it will be realised that a great deal of the spring pressure which should be forcing the friction surfaces together will be dissipated at these two points, thus preventing the clutch springs from exerting their full pressure on the clutch plates. When this occurs, slipping of the clutch will take place, and it will be necessary to readjust the clutch withdrawal mechanism in order to obtain the required clearance.

Removal of the small rectangular plate in the top of the clutch housing will give access to the adjustment for the withdrawal levers. The withdrawal lever restraining springs are for the purpose of preventing the withdrawal levers from being forced against the withdrawal race under the influence of centrifugal action and thus produce undue wear of the race itself and the ends of the levers. They are carefully positioned at the Works and should not be interfered with. If on inspection it is found that there is no clearance at all between the levers and their springs, the lock nut on each lever should be released and the adjusting screw slackened back by means of a screwdriver until at least a 10-thousandths feeler gauge can be inserted between the end of the adjusting screw and the pressure pin beneath it, and there is a clearance of $\frac{3}{32}$ of an inch between the end of each lever and the face of the clutch withdrawal race. *It is of utmost importance that each*

THE M.G. MIDGET MANUAL

of these levers should be so adjusted that they all have exactly the same clearance between their inner ends and the face of the clutch withdrawal race.

Any clean piece of strip metal $\frac{3}{32}$ inch thick can be inserted and used as a gauge between the two to ensure correct adjustment.

If difficulty is experienced in obtaining the necessary clearance between the adjusting screws and their pressure pins when the clearances at the ends of the withdrawal levers are correctly set, the withdrawal lever retaining springs should be gently opened out by inserting a screwdriver behind them.

Tighten up the adjusting screw lock nuts, taking care not to disturb the setting just obtained, and the clutch adjustment is complete. If this procedure has been correctly carried out, each lever should have an appreciable amount of play when the clutch is fully released.

The clutch plate is carried on the splined end of the driven shaft, and may stick when the fabric facings are allowed to become much worn. A drop or two of paraffin on the spline will rectify matters, but care must be taken not to use too much or allow any to reach the fabric facings.

When replacing the inspection cover do not straighten out the lip at the end. This cover-plate is intended to function as a breather for the clutch housing.

Steering Gear.—If the steering column shows signs of end play, this may be corrected by slacking back the the lock nut which is to be found immediately below the steering wheel and given the adjusting nut a fraction of a turn. Care should be taken to lock the lock nut in position again. A complete worm wheel is provided and may be set in a number of alternative positions. Should the steering wheel show an excessive amount of play, all the connections between the steering gearbox and the front axle should be examined to detect any looseness. If no looseness is apparent there is probably some wear in the steering worm wheel, which should be turned 90 degrees to a new position. To effect this the steering arm below the steering gearbox should be removed, after removing the stop plate which spans it. The worm wheel can then be turned through 90 degrees by rotating the steering

ADJUSTMENTS

wheel, and the lever put on in the new position. The stop plate should then be replaced.

Shock Absorbers.—These are correctly set for average loads before the car leaves the Works, but a little looseness may become apparent after the first few hundred miles, rendering adjustment necessary. This is effected by means of the large hexagon nut with pointer attached, which is turned *clockwise* (ordinary right-hand thread) to tighten the shock absorber. The dial is graduated 0, 2, 4, 8, and the pointer should not be moved more than one degree at a time, testing repeatedly (preferably at speed on a rough road) until the best setting is found. It is important that the two Hartfords on the same axle be equally adjusted, and they must on no account be lubricated at any point.

Brakes.—The four wheel brake system of the M.G. Midget is simple and efficient, and periodical adjustment for wear an easy matter. The method of operation is easily seen by examination of the system itself; there is one cross shaft, having a single lever, which takes the pull from the pedal, and double ended levers at either end. Bowden cables from these levers run fore and aft to the brake cam levers.

The main adjuster is incorporated in the rod from the pedal to the cross shaft, and is accessible through the floor boards on the driver's side. It consists of a toggle and two lock nuts: these lock nuts are slacked back (one has a left-hand thread), and the toggle turned with a spanner. It will be obviously seen that since one end is screwed right hand and the other left, turning the toggle one way or the other will decrease or increase the effective length of the brake rod, and thus tighten or slacken the whole system.

Individual adjustment for each wheel is provided by Standard Bowden adjusters on the cables, but the use of this adjustment is very seldom required.

The hand brake is connected to the cross shaft by an over-running link and operates all four wheels.

Brake Adjustment Generally.—Brake adjustment is really more a matter of common sense than anything else, and little need be said on the subject. Usually, once new linings have

THE M.G. MIDGET MANUAL

“settled down”—generally a matter of two or three hundred miles—adjustment of individual wheels should be unnecessary until the linings are worn out, all that is required being periodical attention to the main adjuster.

Individual adjustment of each wheel is, however, a simple matter and is worth attention occasionally if braking, steering and road-holding are to be maintained in first-class order. Uneven front braking is particularly to be avoided.

The simplest method is as follows: With all four wheels jacked up, tighten up each yoke until the brake-lining can just be heard scraping against the drum when the wheel is spun. Then *slacken* the yoke *one complete turn*. This will give an approximate setting, but final and accurate results can only be obtained by actual trial on the road.

It should be unnecessary to mention the need for avoidance of excessive tightening resulting in the brakes rubbing even when the brake pedal or hand lever is in the “off” position, and this is best judged by sound as described above rather than by feel.

SECTION IV.

The Carburetter.

The functioning of the carburetter can be followed in detail by reference to Fig. 1. The petrol flow to the jet is governed by a float mechanism of orthodox type, where the rising petrol lifts the the float, forcing it against weighted

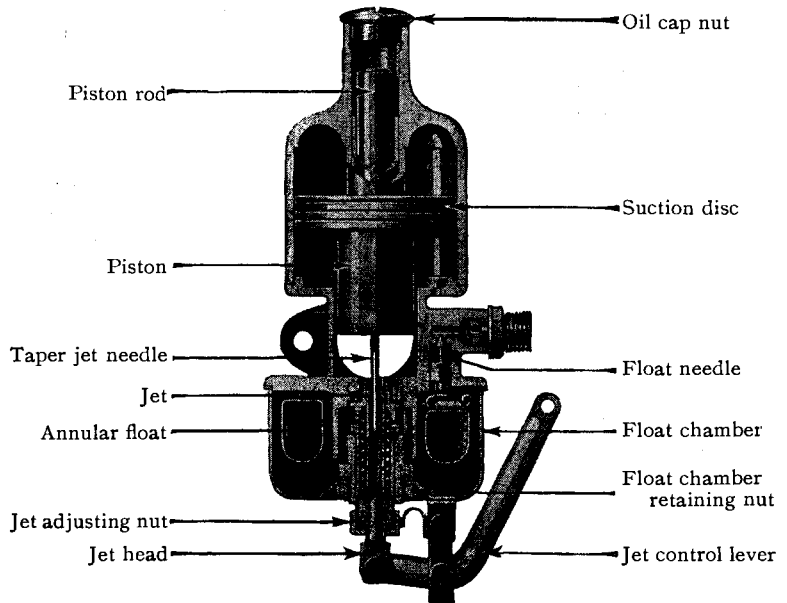

Fig. 1. The S.U. Type M.M. Carburetter in sections clearly showing its internal construction.

levers engaging in a collar at the upper end of a needle. The lower end of the needle terminates in a cone that engages in the conical orifice of the petrol feed pipe, upon which it is forced by the action of the weighted levers, thereby shutting

THE M.G. MIDGET MANUAL.

off the petrol supply when the petrol level in the float-chamber has reached a predetermined level. The weighted levers are attached to the lid of the float-chamber and the lid can readily be detached after sliding the retaining spring catch to one side.

ADJUSTING.

Run the engine until it attains its normal running temperature. Screw the jet adjusting nut upwards as far as it will go and disconnect the mixture control rod from the end of the brass lever actuating the jet. Push this jet actuating lever towards the body of the carburetter as far as it will go, then slowly move it away from the carburetter (thus gradually weakening the mixture) until the engine idles evenly, firing on all four cylinders regularly.

The jet adjusting nut should now be unscrewed until its head just comes into contact with the jet head. This will be the normal slow-running position when the engine is hot, and as the jet needle is of the correct size the general performance of the carburetter on the road should be entirely satisfactory.

The mixture control rod may now be reconnected to the jet actuating lever.

The correct position for the tapered needle is with its shoulder flush with the face of the piston.

Petrol from the float-chamber is led to a jet, the size of whose orifice—and consequent delivery—is regulated by means of a tapered needle attached to the lower end of a piston controlled by the suction from the engine. As this suction increases the needle is gradually withdrawn from the jet, enlarging its effective opening and permitting it to pass more petrol.

The jet is so mounted that it may readily be moved up or down relative to the tapered needle, in order to weaken or strengthen the mixture over the whole working range, by a lever operated from the mixture control lever on the near side of the dash. This control provides an enriched mixture to

THE CARBURETTER

ensure easy starting and even running when the engine is cold. The minimum jet opening can accurately be set by means of the adjusting nut, which forms an abutment for the enlarged head of the jet.

The carburetter is extremely simple, and its adjustment is equally simple if it is remembered that the jet is of a fixed standard size and cannot be altered. The only possible adjustment, other than the slow-running adjustment, is the fitting of a new needle of a different size. Since a needle of the correct size is fitted at the Works before the car is dispatched, this adjustment should not be required, and the suction chamber is therefore sealed.

Sources of Trouble.—There are only three troubles which may affect the functioning of the S.U. carburetter.

1. The piston may be sticking and not functioning properly.
2. There may be dirt or water in the carburetter.
3. The float mechanism may have become deranged, and the carburetter is in consequence flooding.

Piston Sticking.—The suction piston consists of the piston proper forming the choke; the suction disc, into which is inserted the hardened and ground piston rod working in a bearing in the suction chamber; and a tapered needle regulating the jet opening. If the piston is sticking this can easily be ascertained by inserting a finger in the air intake and raising the piston. The piston should come up quite freely and return to its seat with a click as soon as it is released.

The piston rod sliding within its bearing is the only part which is in actual contact with any other part, the suction piston and its needle possessing a clearance space around them. If, therefore, the piston does not return readily to its seat it is probable that the piston rod has become dry or sticky.

To free this, remove the oil cap nut to be found at the top of the suction chamber, pour in a few drops of good quality thin oil—such as sewing machine oil—and replace the cap. In particular obstinate cases a little paraffin may be introduced into the oil cap opening and the piston worked up and down until it is free by inserting a finger in the air inlet. *Under no circumstances should a heavy-bodied lubricant such as*

THE M.G. MIDGET MANUAL

engine oil be used, and no oil must be introduced on any other part of the suction chamber.

Water or Dirt.—If this is suspected, with a small article—such as a pencil—raise the piston so that the jet can be seen. Flood the carburetter by holding up the float-chamber needle and observe if the petrol issues freely from the jet. If it does not do so there is foreign matter of some sort blocking the passage to the jet. To rectify this, start the engine and open the throttle, then momentarily block the air inlet by placing the hand over it, keeping the throttle open until the engine commences to race.

This trouble is not a frequent one with the S.U. carburetter owing to the size of the jet and petrol passages. When it does occur, however, the foreign matter can usually be cleared by the foregoing treatment. If it is not, the only alternative is to remove the jet, *but this expedient should on no account be resorted to unless the method outlined has failed to effect a clearance and it is absolutely necessary to do so.*

Removing the Jet.—If it is necessary to remove the jet the exact position of the jet adjusting nut should first be noted. A file mark on one of the hexagon flats will facilitate this. Then disconnect the jet control lever. The jet adjusting nut should now be screwed home to its top position, carefully noting the number of turns it has been given. It can then be removed by unscrewing the jet holding screw—the upper large hexagon head nearest to the carburetter body—after uncoupling the jet controlling lever.

When refitting the jet it has to be very carefully centred so that the needle is exactly in the centre of the jet opening, but it is practically impossible correctly to centre this part unless it is thoroughly understood how this has to be carried out.

Replacing and Centring the Jet.—It must be understood that, although the needle is very nearly as large as the jet orifice within which it works, yet it must on no account touch at any point.

Replace the jet, taking care that the parts are assembled in their correct position (see Fig. 2).

Having done this, feel if the piston is perfectly free by raising it with the finger. If it is not, slacken the jet screw a

THE CARBURETTER

fraction of a turn, screw up again, and try the piston again. It may be necessary to slacken the jet several times before the piston is finally perfectly free. As soon as the piston is free the jet adjusting nut can be screwed back to *its original position* (see Adjusting).

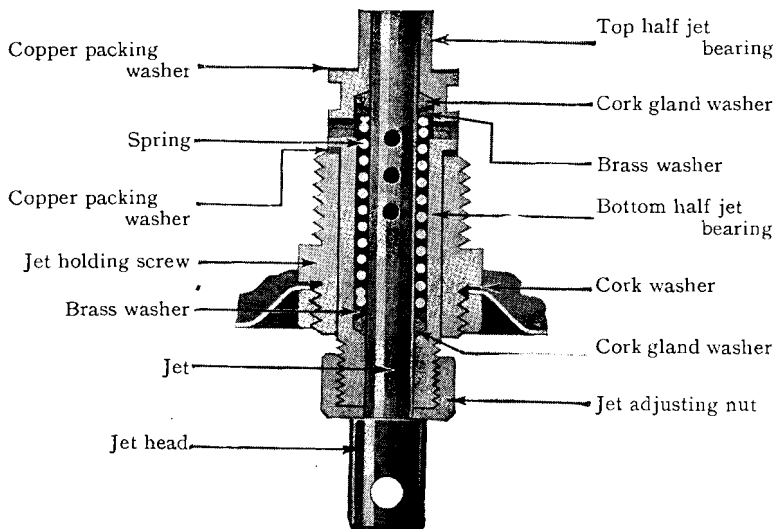

Fig. 2.

An enlarged section of the jet assembly. It will be noticed that the junction between the jet and the jet bearing is rendered perfectly petrol-tight by means of two cork washers which are forced against the sides of the jet by a coil spring and conical washers. If the jet is dismantled great care must be taken not to lose these washers.

A large percentage of the carburetters returned to the Works for correction have had the jet removed and replaced without being correctly centred. On no account should the jet be tampered with.

It is quite an easy matter to bend the needle if the piston is at any time removed, in which case it will bind on the jet and cause the piston to stick. To ascertain if the needle is bent—providing the jet is not out of centre—remove it from the piston, refit the suction chamber on to the body of the

THE M.G. MIDGET MANUAL

carburetter and see if the piston falls freely. If the needle is bent the only satisfactory remedy is to replace it by a new one.

Float-Chamber Flooding.—This is usually obvious from the quantity of petrol flowing over the float-chamber and dripping from the air inlet. Flooding is generally caused by foreign matter finding its way on to the seating of the float-chamber needle. It can usually be removed by raising the float needle, permitting the incoming petrol stream to wash away the particles of grit, and then twisting the needle on its seating a few times with the fingers; the seating should on no account be ground in.

General.—It will be realised from the foregoing that the S.U. carburetter is a very simple instrument and easily managed when understood. On the other hand, considerable damage can be done if it is not treated correctly.

We would emphasise that the three troubles previously outlined are the only ones that can be caused by defects in the carburetter, and if these points are in order the carburetter should on no account be dismantled or altered, since the trouble must lie elsewhere.

SECTION V.

Coil Ignition Equipment.

Very little attention is needed to keep the ignition equipment in first class condition. We advise that it is inspected occasionally, and the following instructions on lubrication, cleaning and adjustment should be carried out.

Distributor.—Occasionally remove the distributor moulding by pushing aside its two securing springs. See that the electrodes are clean and free from deposit. If necessary, wipe out the distributor with a dry duster and clean the electrodes

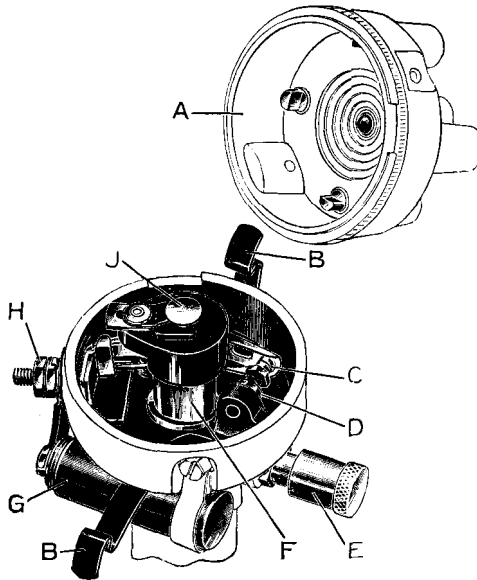

Fig. 1. Distributor and Contact Breaker Type D4-1.

A—Distributor moulding.
B.—Securing springs for
moulding.
C—Contacts.
D—Locking nut.

E—Greaser.
F—Rotating cam.
G—Condenser.
H—Terminal.
J—Spring contact.

THE M.G. MIDGET MANUAL

with a cloth moistened with petrol. Clean the outside of the moulding, particularly the spaces between the terminals. Next examine the contact breaker; it is important that the contacts "C" are kept free from any grease or oil. If they are burned or blackened, they may be cleaned with very fine emery cloth and afterwards with a cloth moistened with petrol. Care must be taken that all particles of dirt and metal dust are wiped away. Misfiring may be caused if the contacts are not kept clean.

The contact breaker gap is carefully set before leaving the Works, and a gauge is provided on the spanner despatched with each distributor. Provided that the cam is kept clean and that the instructions on cam lubrication are carried out, the contact breaker gap will only need adjustment at very long intervals. It is not advisable to alter the setting unless the gap varies considerably from the gauge. If adjustment is necessary, proceed as follows:—When the contacts are fully opened, slacken the locking nut "D" on the stationary contact screw, and rotate it by its hexagon head until the gap is set to the thickness of the gauge. After making the adjustment, care must be taken to tighten the locking nut.

Lubrication.—(1) **Distributor Shaft.** The greaser on distributor shaft should be given one turn about every 500 miles.

Repack the greaser with a good quality high melting point grease when necessary.

(2) **Cam.** About every 3,000 miles, give the cam the slightest smear of vaseline.

Coil.—The coil unit is not adjustable in any way, and requires no attention beyond seeing that the terminal connections are kept tight, and the moulded coil top is kept clean.

Warning Lamp.—A warning lamp is provided in the instrument panel, which gives a red light when the ignition is "ON" and the car is stationary. The warning lamp will also light when the engine is running very slowly, due to the fact that the dynamo is not running at sufficient speed to generate a high enough voltage to actuate the cut-out.

COIL IGNITION EQUIPMENT

The Detection and Remedy of Ignition Faults.—If a failure of ignition or misfiring occurs, unless the cause is at once apparent the owner is strongly recommended to proceed in accordance with the following routine which should quickly enable him to locate the trouble.

Before proceeding with the examination, make sure that the trouble is not due to defects in the engine, carburetter, petrol supply, sparking plugs, etc.

Engine will not Fire.—Switch on the ignition, turn the engine and observe the ammeter reading. The engine should be turned by hand if it is known that the battery is in a low state of charge.

If an ammeter reading is given which rises and falls with the closing and opening of the contacts, then the low tension wiring is in order. If the reading does not fluctuate in this way, a short in the low tension wiring is indicated, or the contacts are remaining closed. When no reading is given, a broken or loose connection in the low tension wiring is indicated, or the battery may be exhausted.

Examine the high tension cables, *i.e.*, cables from the coil to the distributor, and from the distributor to the plugs. If the rubber shows signs of deterioration or cracking, the cable should be renewed. Remove the distributor moulding and examine the contacts; if necessary, clean them as described on page 1. Turn the engine over by hand, and see that the contacts come together.

If a fault is indicated in the low tension wiring, examine the cables from the switch or junction box to coil, and from coil to distributor. See that the battery terminals are tight and that the cables from the switch-box to the battery are secure. The battery may be dismissed as the cause of the trouble if the lamps will light.

Test the coil independently of the distributor as follows:—Remove the cable from the centre distributor terminal, and hold it about $\frac{1}{4}$ in. from some metal part of the chassis and turn the engine. The sparking should be strong and regular if the coil is functioning correctly.

THE M.G. MIDGET MANUAL

Misfiring and Bad Starting.—Examine the high tension cables and the plugs. If necessary, adjust the gaps to the correct setting (about 20 thousandths of an inch). Sooty or oiled plugs may be dismantled and washed out with petrol.

The plugs and high tension cables may be tested by removing the plugs in turn and allowing them to rest on the cylinder head and observing whether a spark occurs at the points when the engine is turned by hand. It should, however, be noted that this is only a rough test, since it is possible that a spark may not take place when the plug is under compression.

Remove the distributor moulding and see that the electrodes and contacts are clean. If necessary, clean them as described on page 1. See that the contact gap setting is correct.

If after carrying out the examination suggested, the trouble cannot be found, we advise that the equipment should be examined by the nearest Lucas/Rotax Service Depot, the addresses of which are given at the end of Section VI.

SECTION VI.

Electric Lighting and Starting System.

Dynamo.—The dynamo is mounted on a platform at the front end of the engine, and forms part of the overhead-camshaft drive.

The dynamo requires but little attention; there are a few components, however, which should be inspected occasionally to ensure satisfactory results. These parts are readily accessible by slackening the screw "C" (Fig. 2) and springing the cover "H" off the dynamo.

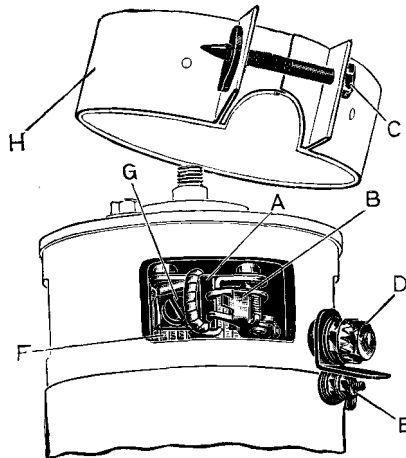

Fig. 2. Dynamo with cover removed.

- | | |
|--------------------------------|-------------------------------------------|
| A—Brush. | B—Spring lever holding brush in position. |
| C—Cover clamping screw. | D—Positive terminal. |
| E—Shunt terminal. | F—Commutator surface. |
| G—Screw securing brush eyelet. | H—Cover. |

THE M.G. MIDGET MANUAL

Brushes.—It is very important to make sure that the three brushes work freely in their holders. This can easily be ascertained by holding back the spring and gently pulling each flexible lead, when the brush should move without the slightest suggestion of sluggishness. The brushes should be clean and should “bed” over the whole of their working surface; that is to say, the face in contact with the commutator should appear uniformly polished. Dirty brushes may be cleaned with a cloth moistened with petrol.

If any of the brushes become so badly worn that it is necessary to replace them, this is accomplished by releasing the brush lead eyelet by removal of the screw “G,” then, while holding the spring lever “B” back out of the way, withdrawing the brush from its holder. The new brush can then be fitted by reversing the operation.

When ordering brush replacements state whether they are main or control brushes, and for what type of machine they are required.

The brush springs should be inspected occasionally to see that they have sufficient tension to keep the brushes firmly pressed against the commutator when the machine is running. It is particularly necessary to keep this in mind when the brushes have been in use for a long time and are very much worn down.

Readers are cautioned that it is unwise to insert brushes of a grade other than that supplied with the machine, or to change the tension springs. The arrangement provided has been made only after many years’ experience, and will be found to give the best results.

Commutator.—The surface of the commutator should be kept clean and free from oil and brush dust, etc.; neglect of this precaution will result in the commutator becoming blackened, causing sparking to occur at the brushes, and consequent shortening of the life of the machine. The best way to clean the commutator is to insert a fine duster, held by means of a suitably shaped piece of wood against the commutator surface, slowly rotating the armature at the same time.

ELECTRIC LIGHTING AND STARTING SYSTEM

If the commutator has been neglected for long periods, it may need cleaning with fine glass paper, but this is more difficult to do, and should not be necessary if it has received regular attention. The grooves between the commutator segments should be examined occasionally and any deposits of copper or carbon dust may be cleaned out by means of a thin saw blade or similar article.

Lubrication.—As the bearings are packed with grease before leaving the Works, very little attention is needed. A few drops of oil, however, may be added through the lubricators provided, say, every 1000 miles. The reader is cautioned that far more trouble has been caused by excessive oiling than by too little.

After the car has run about 10,000 miles the dynamo should be cleaned, adjusted and the bearings re-packed with grease. This should be entrusted to the nearest Lucas/Rotax Service Depot.

Dynamo Field Fuse.—A fuse is provided in the dynamo field circuit to protect the machine in the event of anything being wrong in the charging circuit, e.g. a loose or broken battery connection. If the dynamo fails to charge the battery at any time (indicated by the ammeter giving a discharge reading during daytime running), inspect the fuse and if it has blown, replace it. If the new fuse blows after starting up, the cause of the trouble must be found, and we advise that the equipment is examined by a Lucas/Rotax Service Depot. Replacement fuses must be of the same size as those originally fitted.

With the Two Seater Model, the fuse is carried in the instrument panel. The holder can be withdrawn from the front of the panel.

In the case of the Coupé Model, the fuse is one of the four cartridge type fitted in the CJF type junction box on the engine side of the dash (see page 9), and is marked F1. The size of the fuse is marked on a coloured paper slip which can be seen inside the fuse.

Removing the Dynamo.—In order to obtain easy access to the dynamo for removal it is necessary to take off the radiator.

THE M.G. MIDGET MANUAL

Drain the radiator by opening the tap in the lower water tank under the bonnet, and while the water is running away take off the bonnet by removing the two retaining screws which attach the bracket at the rear end of the bonnet rod to the scuttle apron. When the radiator is empty, disconnect the top water connection by removing the two screws which attach it to the front face of the cylinder head. This will enable the top water connection to be withdrawn with the radiator. Disconnect the rear clip on the lower hose pipe and loosen the hose from the water inlet pipe. Remove the two bolts fastening the radiator to the chassis frame, slacken the nuts at the rear end of the bonnet rod and release it from its bracket. This will permit the removal of the radiator complete with bonnet rod.

Between the projecting portion of the cylinder head and the top of the dynamo will be found a circular flexible coupling. Remove the nuts on each of the four coupling bolts in turn, leaving the bolts in position, so that the coupling can be rotated by use of the starting handle to bring each bolt into a position where the nut may easily be reached.

Having removed all four nuts, take off the valve gear cover and turn the engine by the starting handle until the timing marks on the spiral bevel gears coincide. These will bring the driving yoke on the cylinder head across the engine, and the driving yoke on the dynamo parallel to the engine centre line. The bolts themselves may now be withdrawn, care being taken not to lose the distance washers, which must be replaced in the same position. Removal of the bolts enables the flexible coupling to be withdrawn.

Detach the two cables on the distributor side of the dynamo, noting from which terminal they are removed, and disconnect the oil delivery pipe on the manifold side of the engine at its upper end, taking particular care not to lose the oil restrictor pin beneath it, or its jointing washer.

Remove the two bolts securing the body of the large external oil filter to its supporting bracket. Now unscrew the four set-screws which attach the dynamo to its platform at the front of the engine, releasing the dynamo and the filter bracket. Lift the dynamo approximately a quarter of an inch and tilt it towards the near-side of the car until the driving yoke on

ELECTRIC LIGHTING AND STARTING SYSTEM

the dynamo is just clear of that on the cylinder head. The dynamo can then be tilted forwards and easily withdrawn.

Replacement of the dynamo is effected in the reverse way, but it is necessary to make sure that the engine timing has not been disturbed while the dynamo was removed. Removal of the rectangular cover-plate in the clutch housing—just in front of the gear lever—should reveal the timing mark on the fly-wheel for Nos. 1 and 4 cylinders, exactly in the centre of the opening. Place the brass packing pieces which fit under the dynamo base in position on the dynamo platform, making sure that you replace the same number that you took off. If for any reason the dynamo is replaced by another, it may be necessary to readjust the mesh of the driving gears to obtain silent running by suitable selection of the packing shims used. Turn the dynamo spindle until the timing mark on the dynamo drive gear coincides with the centre line of the dynamo and is at the rear—that is, ready for engagement with the correspondingly marked teeth of the drive gear on the crankshaft. The holes in the dynamo coupling yoke will then be parallel with the engine centre line. Tilting the dynamo towards the near-side of the car and holding the dynamo coupling yoke in this position, insert the drive gear into the opening of the dynamo platform and swing the dynamo backwards and downwards into position. The gears can be felt to be meshing properly if the coupling is slightly oscillated as the dynamo is replaced, but do not overdo the oscillations or you may engage the wrong teeth.

See that the bolts in the dynamo base are coinciding with the holes in the dynamo platform, and then observe if the dynamo coupling yoke is exactly parallel to the engine centre line. If it is not, withdraw the dynamo, reset the coupling yoke and reinsert the dynamo. No difficulty should be experienced in getting the dynamo in position with the correct teeth in mesh, as the distance between one tooth and the next is sufficient to make an appreciable difference to the position of the dynamo coupling yoke, a difference which is immediately discernible.

Having satisfied yourself that the correct gear teeth are in mesh, replace the oil filter bracket and the screws in the dynamo base, taking particular care to tighten them up evenly a partial turn at a time until all are quite tight.

THE M.G. MIDGET MANUAL

Now make a final test. The flywheel mark $1\frac{1}{4}$ should show exactly in the centre of the inspection cover opening with the distributor rotating arm pointing towards No. 1 cylinder. (This can easily be found by tracing the high-tension lead from No. 1 sparking plug to its junction on the distributor. Removal of the distributor cover should show the distributor arm directly beneath it.) The dynamo coupling bolt holes should be exactly fore and aft and at right angles to the coupling yoke on the cylinder head, and the timing marks on the camshaft driving gears should be coinciding.

If all the foregoing are correct, replace the flexible coupling and coupling bolts, taking care to replace the distance washers in exactly the same position as they were originally. Tighten up the nuts firmly and rotate the engine slowly by hand. If the distance washers are in the correct position, the flexible coupling should run absolutely true. If it does not do so, note where the error is and adjust the distance washers accordingly. Replace the valve cover, attach the dynamo cables on to their correct terminals, and reconnect the oil delivery pipe on to the cylinder head. It is an advantage to withdraw the oil restrictor pin before doing this and wash it in paraffin to make sure that it is perfectly clean.

Replace the radiator and bolt the upper water connection to the forward face of the cylinder head, not forgetting to replace the jointing washer. Engage the rear end of the bonnet rod in its bracket and tighten up the nuts. You may now connect up the bottom hose and replace the bonnet, thus completing the reassembly.

Starting Switch.—The switch is extremely simple in construction, and as there are no working parts liable to get out of order, the contacts are permanently enclosed. Operate the switch firmly and quickly, both in switching on and releasing.

Starter Motor.—The armature spindles of these machines are fitted with a pinion which, on rotation, runs into engagement with the geared ring on the flywheel. Immediately the engine begins to fire, the pinion is automatically thrown out of mesh.

If, for any reason, the pinion wheel on the motor does not

ELECTRIC LIGHTING AND STARTING SYSTEM

engage with the flywheel teeth, examine the screwed sleeve on the armature spindle to see that it is free from dust; if necessary, wash over with paraffin. Occasionally give it a few drops of thin machine oil.

As in the case of the dynamo, the surface of the commutator must be kept clean and free from oil, brush dust, etc.

The starter is designed for starting the engine under normal conditions, but any unnecessary or additional loading will considerably diminish the life of the machine and battery. In order to facilitate starting in cold weather, it is advisable to flood the carburetter, and, before using the electric starter, crank the engine over slowly by the starting handle for two or three revolutions; this will break the oil film and considerably diminish the load for starting.

In the event of the engine refusing to fire after being turned by the starter, make sure that the ignition switch is "on."

Battery.—It is of the utmost importance that the battery should receive regular attention, as upon its good condition depends the satisfactory functioning of the ignition, starting motor, and the lamps.

At least once a fortnight the vent plugs in the top of the battery should be removed, and the level of the acid solution examined. If necessary, distilled water (which can be obtained at all chemists and most garages) should be added to bring the level well above the plates. If, however, acid solution has been spilled, it should be replaced by a diluted sulphuric acid solution of specific gravity 1.320. *It is important, when examining the cells, that naked lights should not be held near the vents, on account of the possible danger of igniting the gas which is generated by the plates.* It is advisable to complete the inspection by measuring the specific gravity of the acid, as this gives a very good indication of the state of charge of the battery. An instrument known as a hydrometer is employed for this purpose; these can be bought from your Dealer or from any of the Lucas/Rotax Service Depots.

For the battery fitted to the M.G. Midget, the specific gravity readings will be 1.285—1.300 for a fully charged

THE M.G. MIDGET MANUAL

battery, about 1.210 when half discharged and about 1.150 when fully discharged.

If one cell gives a reading very different from the rest, it may be that electrolyte has been spilled or has leaked from this cell, or there may be a "short" between the plates. In the latter case, the battery should be examined as soon as possible by a Lucas/Rotax Service Depot.

Finally, see that the tops of the cells are clean and dry, and that the terminals are tight and smeared with vaseline.

If the equipment is laid by for several months, the battery must be given a small charge from a separate source of electrical energy about once a fortnight, in order to obviate any permanent injury to the plates.

Under no circumstances must the acid be removed from the battery and the plates allowed to dry, as certain changes take place which result in loss of efficiency.

The battery must never be left in a fully discharged condition, and, unless some long runs are to be taken, it is advisable to have the battery removed from the car periodically and charged up from an independent electrical supply.

Switches.—*Coupe only.* The S.A.I. Switch is a combined Ignition and Lighting Switch. The Ignition Switch is key controlled in the centre of the unit.

The Lighting Switch has three positions, which, from left to right, are :—

“ OFF ”—Lights off. Dynamo on.

“ SIDE ”—Sidelamps and Tail on. Dynamo on.

“ HEAD ”—All Lamps on. Dynamo on.

2-Seater Model. The Ignition Swith is of the key type, positioned between the speedometer and the ammeter. The Lamp Switch is immediately above the ammeter and has three positions marked D, S and H, which gives similar control to the type S.A.I switch but working from right to left.

ELECTRIC LIGHTING AND STARTING SYSTEM

Ammeter.—The centre-zero ammeter which is incorporated in the instrument panel indicates the actual current flowing into or out of the battery. For instance, suppose two amperes are consumed when the side- and tail-lamps are switched on, and the ignition coil takes one ampere, then if the dynamo is generating at seven amperes the meter will show four amperes on the charge side of the scale. This is the current in excess of the lamp and ignition load which is available for battery charging purposes.

Combined Junction Box, Cut-out and Fuse Unit, Type CJF1. Coupé Model. This unit is mounted on the engine side of the dash, and it houses the cut-out and fuses on its one side, while its other side forms a junction box. All terminals are marked with letters on the moulding, and the ends of the cables are given on the wiring diagram so that the wiring can easily be traced.

Terminals are provided in the Junction box for wiring up any extra accessories the owner may wish to fit. These terminals are readily accessible when the cover is removed, the one marked "AUX" is the positive feed, and the other marked "E" is the negative or earth return. When wiring up accessories it is advisable to remove the fuse while wiring is being carried out. To make efficient connections to terminals proceed as follows:—

Bare about $\frac{3}{8}$ in. of the cable, twist the wire strands together and turn back about $\frac{1}{8}$ in. so as to form a small ball. Remove the grub screw from the appropriate terminal and insert the wire so that the ball fits in the terminal post. Now replace and tighten the grub screw, this will compress the ball to make a good electrical connection.

Fuses.—There are four fuses, of the cartridge type, which protect the equipment in the event of short circuits. One, marked "H," protects the headlamps; another, marked "S & T," the side and tail lamps; the third, marked "AUX," the circuits of the auxiliary accessories, which include the horn, electric windscreen wiper, etc., and the fourth "F1" the dynamo.

THE M.G. MIDGET MANUAL

The separate fusing of the various circuits ensures that a short in any one does not affect the rest of the electrical equipment. This is particularly important when coil ignition is fitted. It will be noticed that the fusing of the lamps is such that there is no risk of the driver being plunged into total darkness. If both the headlamps, or the side and tail lamps, or all the units connected to the auxiliary accessory terminal fail to function, examine the particular fuse protecting them. Remove the fuse from its holder and see whether there is a break in the fuse wire. Before replacing the fuse, inspect the units that have failed, for evidence of short circuits or other faults that may have caused the fuse to blow.

If a fuse blows repeatedly, and the cause cannot be traced, we advise that the equipment is examined by a Lucas/Rotax Service Station.

The Cut-out.—The function of the cut-out is to close the charging circuit, as the increasing engine speed when the car is starting, causes the dynamo voltage to rise above that of the battery. When the engine slows down, the dynamo voltage falls below that of the battery, and the reverse action takes place, i.e., the cut-out opens and thereby prevents the battery from discharging itself through the dynamo.

The question is sometimes asked whether the operation of the cut-out in any way depends upon the state of charge of the battery. There is no such relation between the two; the sole function of the cut-out is to switch on the dynamo with rising engine speed and to disconnect it when the engine slows down to below a certain speed. The cut-out is accurately set before leaving the Works and does not need any adjustment, and therefore the cover protecting it is sealed.

2-Seater Model. The Cut-out is a separate unit and no Junction Box is provided.

The Dynamo shunt field fuse is a detachable unit on the F.T.55/3 fascia plate on the dash.

ELECTRIC LIGHTING AND STARTING SYSTEM

Headlamps.—The headlamps are provided with a patented universally adjustable mounting which allows the beam of light to be set to the best advantage. This adjustment is obtained by slackening the hexagon locking nut “A” (Fig. 4), turning the lamp to the desired position and then locking it by tightening up the nut.

The near side Headlamp is set to throw its beam to the near side of the road and the off side (set straight) can be turned off or on independently.

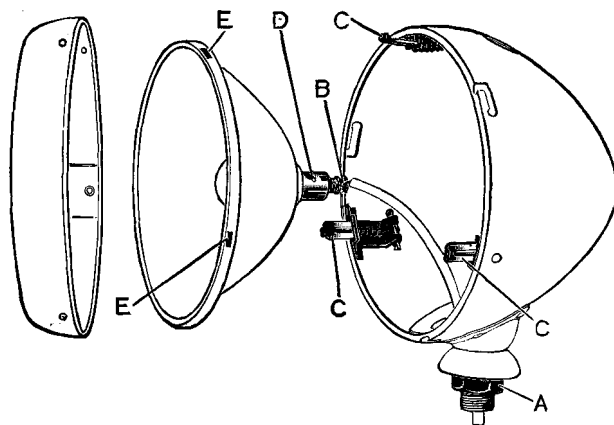

Fig. 4. Headlamp dismantled.

- | | |
|----------------------------------------|------------------------------------------------|
| A—Locking nut for adjustable mounting. | C—Cylindrical sockets holding locking springs. |
| B—Spring terminal. | D—Focussing notches. |

Removing the Front and Reflector.—The Headlamps are constructed with detachable fronts, parabolic reflectors and focussing devices. To remove the front the round headed screw at the top of the lamp should be unscrewed and the front turned to the left as indicated by the arrow stamped on the rim. With the type of lamp illustrated in Fig. 4 it is only necessary to turn the front to the left to remove it. The reflector is held in position by three supports “C” from which it can be readily removed when necessary to re-focus

THE M.G. MIDGET MANUAL

the bulb. Lamps are correctly focussed when sent out from the Works, but if a bulb is replaced it may be necessary to adjust the focus of the lamp. Accurate focussing is imperative if the maximum results are to be attained. The method of focussing is as follows :—

Remove the front as above, remove the screws or spring ring holding reflector and then carefully draw forward the reflector until the lamp holder is exposed. This holder is fixed by a screw and may be moved backwards or forwards when the screw is loosened. Each lamp must be focussed separately, care being taken that lamps are properly set in line, not pointing up or down. Correct focussing adjustment is obtained by reflecting lamps on to a wall or, preferably, a white object at a distance of about 100 yards, sliding holder backwards or forwards until the light reaches its highest point of brilliancy with total absence of shadows. Then tighten screw and replace the reflector and front.

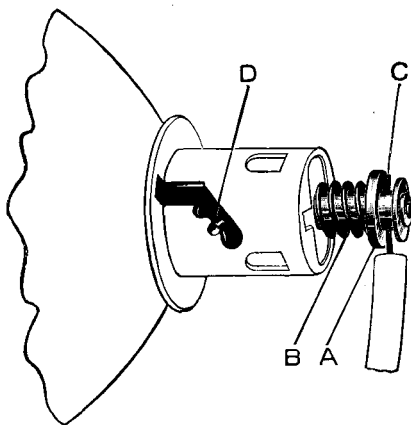

Fig. 5. Lamp Terminals and three notch focussing arrangement.

A—Washer.

C—Hole in stem.

B—Spring.

D—Focussing notches.

With some lamps the lamp holder is provided with three notches. By trying the bulb in the alternative positions the best results can be obtained.

ELECTRIC LIGHTING AND STARTING SYSTEM

Wiring Headlamps.—Remove the front and reflector as described in a previous paragraph. Then depress the insulating washer "A" (Fig. 5) against the spring "B" until the hole "C" is exposed. Thread the cable end through the hole, release the pressure on washer "A," when the cable will be securely held in position and good contact made. Cables should not be pushed too far through the terminal, as there is a danger of shorting on to the reflector or body of the lamp.

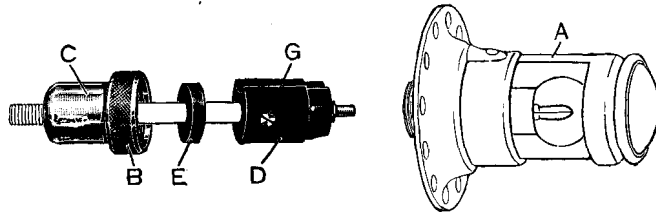

Fig. 6. Tail Lamp Type TF201.

- | | |
|-------------------------|-------------------------|
| A—Lamp front. | D—Cable plug. |
| B—Coupling nut. | E—Rubber washer. |
| C—Cable covering shell. | G—Cable securing screw. |

Side-lamps.—The fronts of the wing lamps are secured by small grub screws; when these are removed the fronts can be screwed out.

Tail-lamp.—The tail-lamp is fixed on to the car by means of a flanged base. To replace a bulb turn the front portion of the lamp "A" (Fig. 6) to the left and withdraw it from its base.

When replacing see that the studs locate with the slots in the lamp front, then push it home to lock it in position. Should it be necessary to re-wire the tail-lamp, unscrew the coupling nut "B," when the cable covering shell "C" and the cable plug "D" can be withdrawn from the lamp; pass the cable through the shell and the rubber washer "E." Thread the bared end of the lead into the terminal socket and secure by the screw "G." Replace the cable plug in its holder and secure by tightening the coupling nut "B."

THE M.G. MIDGET MANUAL

Replacement of Bulbs.—When the replacement of any bulb is necessary we strongly advise that Lucas/Rotax bulbs are used. The filaments are arranged to be in focus and give the best results with the lamps fitted. The following are the correct bulbs to use :—

Headlamps B.A.S. No. 2S, 6 volt, 18 watt.

Side and Tail B.A.S. No. 8S, 6 volt, 3 watt.

Cleaning Lamps.—The reflectors are protected by a transparent and colourless covering, which enables any accidental finger marks to be removed with chamois leather or a soft cloth without affecting the surface of the reflector. Do not use metal polishes on Lucas Reflectors. Ebony black lamps can be cleaned with a good car polish. Chromium plated lamps will not tarnish and only need wiping over with a damp cloth to remove dust or dirt.

Lucas Altette Horn (Type HF311).—All electric horns, before being passed out of the Works, are adjusted to give the best performance, and they will give long periods of service without any attention.

The adjustment of a horn does not alter the characteristic of the note as is sometimes supposed, but takes up the wear of vibrating parts. Do not alter the adjustment unnecessarily. If the horn becomes uncertain in its action, giving only a choking sound, or does not vibrate, it does not follow that the horn has broken down. First ascertain that the trouble is not due to some outside source, e.g. a discharged battery, a loose connection or short circuit in the wiring of the horn, or in some cases a blown fuse. It is also possible that the performance of a horn may be upset by the horn becoming loose on its mounting. Also see that the front or grille is secure.

The horn is adjusted by moving the screw in the centre of the grille. This screw is notched on its underside. Do not turn it through more than one or two notches at a time. The best adjustment can be found by trial. If, after the adjustment, the tone of the horn is still unsatisfactory, the owner is urged to return it to a Lucas/Rotax Service Depot to have other adjustments made.

ELECTRIC LIGHTING AND STARTING SYSTEM

Electric Windscreen Wiper (Type MT1).—To start the wiper, pull out the curved handle and swing it aside so as to move the cleaning arm into position on the screen. Then pull out the switch knob and give it a spin. To stop the wiper, push in the knob. Then pull out the curved handle to disengage the wiper blade from its drive, and turn the end of the handle over the switch knob. This locks the cleaning arm out of the line of vision of the driver and ensures that the wiper is switched off.

Unless the wiper is switched off when not in use, it may be irretrievably damaged.

The wiper requires absolutely no attention; all moving parts are packed with grease during assembly, and no lubrication is necessary.

When cleaning the windscreen, the wiper arm can be easily lifted from the glass, but care must be taken that it is not moved from side to side.

If the rubber squeegee becomes worn or perished, it can be easily replaced at very small cost.

LUCAS—C. A. V.—ROTAX SERVICE DEPOTS

In the event of any difficulty with any part of the equipment, no matter how trivial, we shall be only too pleased to give every assistance possible. The best course to adopt is to call at the nearest Lucas Service Depot, the addresses of which are given below, when the equipment can be examined as a whole. The depots are not only at your disposal for repairs, overhauls and adjustments, but to give free advice. If it is necessary, however, to communicate, or when ordering spare parts, always give the type and number of the unit in question, the make and, if possible, the date of the car on which it is fitted.

BELFAST	3-5 Calvin Street, Mount Pottinger
Telephone: Belfast 7017	Telegrams: " Servdep, Belfast "
BIRMINGHAM	Great Hampton Street
Telephone: Central 8401 (10 lines)	Telegrams: " Lucas, Birmingham "
BRIGHTON	Old Shoreham Road, Hove
Telephone: Preston 3001 (4 lines)	Telegrams: " Luserv, Brighton "
BRISTOL	345 Bath Road
Telephone: Bristol 8400 (4 lines)	Telegrams: " Kingly, Bristol "
CARDIFF	54a Penarth Road
Telephone: Cardiff 4603 (4 lines)	Telegrams: " Lucas, Cardiff "
COVENTRY	Priory Street
Telephone: Coventry 3068 & 3841	Telegrams: " Lucas, Coventry "
DUBLIN	Portland St. North, North Circular Road
Telephone: Drumcondra 434 (6 lines)	Telegrams: " Luserv, Dublin "
EDINBURGH	32 Stevenson Road, Gorgie
Telephone: Edinburgh 62921 (4 lines)	Telegrams: " Luserv, Edinburgh "
GLASGOW	227-229 St. George's Road
Telephone: Douglas 3075 (5 lines)	Telegrams: " Lucas, Glasgow "
LEEDS	64 Roseville Road
Telephone: Leeds 28591 (5 lines)	Telegrams: " Luserdep, Leeds "
LIVERPOOL	450-456 Edge Lane
Telephone: Old Swan 1408 (3 lines)	Telegrams: " Luserv, Liverpool "
LONDON	Dordrecht Road, Acton Vale, W.3
Telephone: Shepherd's Bush 3160 (10 lines)	Telegrams: " Dynamagna, Act, London "
LONDON	759 High Road, Leyton, E.10
Telephone: Walthamstow 2161 (3 lines)	Telegrams: " Luserdep, Walt, London "
LONDON	155 Merton Road, Wandsworth, S.W.18
Telephone: Putney 5131 (4 lines) & 5501	Telegrams: " Luserv, Wands, London "
MANCHESTER	Talbot Road, Stretford
Telephone: Longford 1101 (5 lines)	Telegrams: " Lucas, Stretford "
NEWCASTLE-ON-TYNE	64-66 St. Mary's Place
Telephone: Central 3571 (3 lines)	Telegrams: " Motolite, Newcastle-on-Tyne "

In addition there are official Battery Service Agents in important centres throughout the country.

Maintenance Summary.

The following is a guide to the regular lubrication and other attentions required by the chassis. As far as possible these should be controlled by *mileage* rather than *time*, as a car may cover 50 miles one week and 1000 the next. Full details of the various operations will be found in the Sections indicated by the figures in brackets.

Every Day or 100 miles: Check water level in radiator (I) and oil level in engine (II).

After the first 100 miles, and every subsequent 500 miles, remove oil restrictor pin and external oil filter and clean thoroughly (II).

Every 500 miles: Lubricate gearbox, back axle and chassis generally (II).

Every Week: Tighten wheel nuts and check tyre pressures (I).

Every 1000 miles: Change Engine Oil (II).
Lubricate distributor (V), Dynamo (VI), and Hubs (II).

Every 1000, or once a fortnight: Check battery acid level.

Every 2000 miles: Examine valve rocker clearances (III).
Examine ignition system and sparking plugs (V).

Every 3000-4000 miles: Drain and refill gearbox and back axle (II).

Every 5000 miles: Decarbonise engine and grind valves (III).

Every 10,000 miles: Overhaul electrical system thoroughly (best at Lucas Service Station, M.G. Works, or M.G. Agent).

Periodical Overhauls.—Every car which has covered a large mileage during the course of a season or two requires a general overhaul, which is beyond the owner's ability. The M.G. factory at Abingdon-on-Thames has a large service station devoted exclusively to the overhauling and repairing of M.G. cars, and owners are invited to take advantage of the facilities available.

M.G. Radiator Main Service Stations.

1. **BELFAST.** Serck Radiators Ltd., 59 May Street.
Telephone : 6938. *Telegrams* : " Serckrad," Belfast.
2. **BIRMINGHAM.** Coventry Radiator & Presswork Co. Ltd.,
107 Pritchett Street.
Telephone : Aston Cross 1623. *Telegrams* : Covradco, Birmingham.
3. **BRISTOL.** Alfred J. Rees & Son, Bishop Street, Moorfields.
Telephone : 5174 (2 Lines).
4. **CARDIFF.** Serck Radiators Ltd., 60a Clive Road, Canton.
Telephone : 6124 (Central). *Telegrams* : Serckrad.
5. **COVENTRY.** Coventry Radiator & Presswork Co. Ltd.,
Raglan Works, Lower Ford Street.
Telephone : 3071 (3 Lines). *Telegrams* : Covradco, Coventry.
6. **DUBLIN, I.F.S.** George Pappin & Sons, 25 Whitefriar Street.
Telephone : 51607.
7. **LEEDS.** Excelsior Motor Radiator Co. Ltd., Oldfield Lane.
Telephone : Armley 38041-2. *Telegrams* : Cooling, Phone, Leeds.
8. **LIVERPOOL.** Liverpool Radiator Co. Ltd., Fontenoy Street.
Telephone : Central 382-3. *Telegrams* : Liveradco, Liverpool.
9. **LONDON, N.W.10.** Serck Radiators Ltd., Park Royal Road.
Telephone : 5441-2. *Telegrams* : Serckrad.
10. **MAIDSTONE.** Serck Radiators Ltd., Palace Avenue.
Telephone : 1035. *Telegrams* : Serckrad.
11. **NEWCASTLE-ON-TYNE.** Serck Radiators Ltd., Skinnerburn Road.
Telephone : Central 5863. *Telegrams* : Serckrad.
12. **NOTTINGHAM.** Minerva Motor Radiator Co.,
Boulevard Works, Radford.
Telephone : 75631. *Telegrams* : Motorad, Nottingham.
13. **SHEFFIELD.** The Excelsior Motor Radiator Co. Ltd., Jessop Street.
14. **SOUTHAMPTON.** Serck Radiators Ltd., Ryde Terrace, Floating Bridge.
Telephone : 3560. *Telegrams* : Serckrad.
15. **SUFFOLK.** Serck Radiators Ltd., Cornard Works, Sudbury.
Telephone : 57. *Telegrams* : Serckrad.
16. **STOKE-ON-TRENT.** Coventry Radiator & Presswork Co. Ltd.,
56a Ashford Street, Shelton.

M.G. Radiator Sub Service Stations.

1. **ABERDEEN.** Francis Craigmile & Son, 56 Gordon Street.
Telephone : 3599.
2. **BOURNEMOUTH.** Hants & Dorset Sheet Metal Co., 154 Ashley Road.
Telephone : 2840.
3. **BRIGHTON.** Brighton Motor Sheet Metal Works, 50a St. James Street.
Telephone : 2191-2.
4. **CARLISLE.** Serck Radiators Ltd., Hardwick Circus, Lowther Street.
Telephone : 1119. *Telegrams* : Serckrad.
5. **EDINBURGH.** Alder & Mackay Ltd., Stewart Terrace.
Telephone : 61151-2. *Telegrams* : Alder, Edinburgh.
6. **EXETER.** Saunders & Biss Ltd., 172 Sidwell Street.
Telephone : 3813. *Telegrams* : Radiators, Exeter.
7. **GLASGOW, C.4.** J. C. Urie & Co., 399 Parliamentary Road.
Telephone : Douglas 3062. *Telegrams* : Radiators, Glasgow.
8. **HULL.** Bowman's Hull Sheet Metal Works, Boothferry Road.
Telephone : Central 2319.
9. **LEICESTER.** Victory Radiator & Welding Works, 60 Church Gate.
Telephone : Leicester 20189.
10. **LEIGH-ON-SEA.** John Keeling & Son, Grand Garage, The Broadway.
11. **LIVERPOOL.** W. Watson & Co. (Liverpool) Ltd., 9 Upper Duke Street.
Telephone : 2345 (Royal) 4 lines.
12. **MANCHESTER.** The Pendleton Radiator Co., 72a Broad Street,
Pendleton.
Telephone : 709. *Telegrams* : Necessity, Manchester.
13. **NORTHAMPTON.** Central Sheet Metal Works, 12a St. Michael's Rd.
Telephone : 676.
14. **NORWICH.** W. F. Smith & Son, 90 King Street.
Telephone : Norwich 30.
15. **PERTH.** Leslie & Murray, St. Catherine's Road.
Telephone : 770.
16. **PLYMOUTH.** Edmund Metal Works, Sutton Road.
Telephone : 2181. *Telegrams* : Edmund Metal Works, Plymouth.
17. **SHEFFIELD.** W. H. Tyas & Co., Ball Lane, Carver Street.
Telephone : 22869.
18. **WOLVERHAMPTON.**—Baggott's Motor Fittings, Steelhouse Lane.
Telephone : 110

Recognised M.G. Radiator Repairers.

1. **BELFAST.** Andrew Nullan, 9 Corporation Square.
Telephone : 5891.
2. **BIRKENHEAD.** Birkenhead Motor Radiator Works, 1/3 Ivy Street.
Telephone : 3696.
3. **BIRMINGHAM.** Serck Radiators Ltd., Warwick Road.
Telephone : Victoria 531 (5 Lines). *Telegrams* : Serckrad
4. **BRIGHTON.** J. Lancaster Radiators Ltd., 25a Henry Street.
Telephone : Brighton 1256.
5. **BRISTOL.** Coventry Radiator & Presswork Co. Ltd.,
Armada Place, Stokes Croft.
Telephone : 9665. *Telegrams* : Covradco, Bristol.
6. **BRISTOL.** Perry & Fudge, Globe Works, Horsefair.
Telephone : 2345. *Telegrams* : Ventilator, Bristol.
7. **CHESTER.** Serck Radiators Ltd., Kaleyards, Frodsham Street.
Telephone : 878. *Telegrams* : Serckrad.
8. **LINCOLN.** W. Hindle, 70 Kesteven Street.
Telephone : 679.
9. **LONDON, W.1.** J. Lancaster Radiators Ltd., 151 Wardour Street.
Telephone : Regent 5376—7.
10. **MANCHESTER.** H. O. Serck Ltd., Lyon Street, Garratt Street,
Oldham Road.
Telephone : City 7838 (2 Lines). *Telegrams* : Serckrad.
11. **MANCHESTER.** C. W. Scrouther & Co., 19 East Street,
Lower Mosley Street.
Telephone : 7394 City.
12. **PRESTON.** E. Ashwell & Son, 121a Friargate.
Telephone : 1139 Preston. *Telegrams* : Ashwell, Preston.
13. **SOUTHAMPTON.** J. Lancaster Radiators Ltd., 71 Lyon Street,
Onslow Road.
Telephone : Southampton 3372.
14. **SWANSEA.** B. T. Rees, 53a Oxford Street.
Telephone : 5484.

Main and Sub-Agents.

- ALTRINCHAM.**—Arden & Bull, Old Market Place.
ASHFORD (Kent).—Stanhay (Ashford), Ltd., Elwick Works.
ASHTON-ON-MERSEY (Cheshire).—Gordon Stewart Motors, Ltd., Cross St
BARNSELEY.—H. N. Booker, Ltd., Wellington Garage.
BARROW-IN-FURNESS.—Simpsons, Ltd., 91-93 Duke Street.
BATLEY.—Geo. Box, Ltd., Bradford Road.
BEDFORD.—A. Gell, 6a St. Loyes.
BICESTER.—Layton & Son, London Road.
BIDEFORD.—Heard Bros., Ltd., Westcombe Works.
BIRMINGHAM.—P. J. Evans, Ltd., John Bright Street.
 ,, Frank Hallam, 18-20 Bristol Street.
BOLTON.—Parkers (Manchester & Bolton) Ltd., Bradshaw Gate.
BOURNEMOUTH.—Knott Bros., Ltd., 214 Charminster Road.
BRADFORD.—B. Waterhouse & Sons, Ltd., 75 Manningham Lane.
BRIGHTON.—University Motors, Ltd., Bedford Place.
BRISTOL.—Welch & Co. Ltd., Redcliffe Garage.
BROMLEY (Kent).—J. W. Wood, 1 Ravensfell Parade, High Street.
BYFLEET (Surrey).—Thomson & Taylor (Brooklands) Ltd., Brooklands Tr'k.
CAMBERLEY (Surrey).—Whites Ltd., London Road.
CAMBRIDGE.—King & Harper, Ltd., 6-7 Bridge Street.
CARDIFF.—City Motor Co., Ltd., 99 City Road.
CARLISLE.—Graham & Roberts, 63 Botchergate.
CARMARTHEN.—Lowndes, Ltd., Priory Street.
CHEAM (Surrey).—Cheam Motor Co., Ltd., Ewell Road.
CHELMSFORD.—Eastern Garages, Ltd., Market Road.
CHELTENHAM.—W. G. Tibbles & Co., Ltd., College Road.
CHESTER.—Chester Engineering Co. (1918) Ltd., City Road.
CHICHESTER.—Wadham Bros., South Gate.
COLCHESTER.—P. G. Page, 38 Crouch Street.
COVENTRY.—S. H. Newsome & Co., Ltd., 6 Hales Street.
CROYDON.—Smith's Auto Co., Ltd., 145 London Road.
 ,, Milne & Russell, 1 Brighton Road.
DARLINGTON.—Sherwood Bros., Grange Road.
DERBY.—J. Rayner, Rowditch Garage, Lonsdale Place, Uttoxeter Road.
DEVONPORT.—Kimber's Garage, Albert Road.
DONCASTER.—E. W. Jackson & Son, Ltd., Cheswell Works.
DORKING.—Dorking Motor Co., Ltd., Myrtle Road.
EASTBOURNE.—Parkinson, Polson & Co., Ltd., 16 Cornfield Road.
EXETER.—Abbott & Munday, Clifton Road.
FALMOUTH (Cornwall).—Taylor's Garage.
FAREHAM.—Bennett & Righton, Ltd., West Street.
FLEET (Hants.).—Bradley, Mathew & Co., Ltd.
FOLKESTONE.—Maltby's, Ltd., Sandgate Road.
GUILDFORD.—Haslemere Motor Co., Ltd., Woodbridge Road.
HARROGATE.—B. M. Stuttgart, Knaresborough Road.
HARROW WEALD.—Ray Abbott, Ltd., Memorial Garage.
HENDON.—Home Motor Services, Ltd., 188 Brent Street.
HEREFORD.—J. Fryer, Ltd., Dragon Garage.
HUDDERSFIELD.—Earnshaw, Ltd., 10 Cloth Hall Street.

Heavy type denotes Main Agents.

THE M.G. MIDGET MANUAL

HULL.—Crosland Motor Co. (Hull), Ltd., 77 Anlaby Road.

KING'S LYNN.—Johnson & Sons, Ltd., St. James Street.

LEAMINGTON.—Midland Autocar Co., Russell Street.

LEEDS.—Appleyards of Leeds, Ltd., North Street.

„ Adams Motor Service, Stoney Rock Lane.

„ A. G. Wilson, Harrogate Road, Chapel Allerton.

LEICESTER.—The Park Garage, 146 London Road.

LINCOLN.—Stocks, Ltd.

LIVERPOOL.—Colmore Depot, 24 Paradise Street.

„ W. Watson & Co., Renshaw Street.

LLANELLY.—W. D. John & Co., Ltd., Old Lodge Garage.

LONDON (Central and Eastern).

UNIVERSITY MOTORS LTD., 1 and 4 Brick Street, Park Lane, W.1.

Car Mart, Ltd., 46-50 Park Lane, W.1.

Caflikin Wilkinson & Co., Ltd., 17a Hanover Square.

Membership & Co., Ltd., 405 Kings Street, Hammersmith, W.5.

LONDON (North Eastern).

Car Mart, Ltd., 46-50 Park Lane, W.1.

Lambs, Ltd., opposite Hoe Street Station, Walthamstow, E.17.

LONDON (North Western).

Central Motor Institute & Engineering Co., Ltd., 112a-118a Finchley Rd.,
N.W.3.

George Newman, 369 Euston Road, N.W.1.

Guy Newman, 378-380 Euston Road, N.W.1.

F. L. Cranmore, High Road, Potters Bar, Middlesex.

Henley (1928) Ltd., Hawleys Crescent, Camden Town, N.W.1.

Pass & Joyce, Ltd., 373 Euston Road, N.W.

Elmcroft Auto Sales & Service, Elmcroft Crescent, Golder's Green, N.W.11 .

LONDON (South Western).

Jarvis & Sons, Ltd., Victoria Crescent, Wimbledon, S.W.19.

Boon & Porter, Ltd., 159-163 Castelnau, Barnes, S.W.13.

Platers, Ltd., 376 High Road, Streatham, S.W.16.

Maythorpe Engineering & Motor Works, Mayow Road, Sydenham, S.E.26.

LLANGOLLEN.—Jones Bros. (Llangollen), Ltd., The Garage.

MAIDENHEAD.—Hewens Garages, Ltd.

MANCHESTER.—J. Cockshoot & Co., Ltd., Great Ducie Street.

„ Colmore Depot, 200 Deansgate.

„ Grosvenor Garages, Burnage Lane, Levenshulme.

NEWBURY (Berks).—Stradlings, Ltd.

NEWCASTLE-ON-TYNE.—Frank Scott, Ltd., Central Garage, Carlhol Sq.

NOTTINGHAM.—C. H. Truman & Sons, Ltd., 61a Mansfield Road.

OXFORD.—The Morris Garages, Ltd., Queen Street.

PAIGNTON.—Sansoms Central Garages, Ltd., 3 Hyde Road.

PORTSMOUTH.—United Service Garage, High Street.

PRESTON.—Merigold Bros., Church Street.

Heavy type denotes Main Agents.

List of Spare Parts for the 8/33 M.G. Midget Sports.

Part No.	Description	Per Set	For Stock	Price £ s. d.
ENGINE PARTS.				
35741	Cylinder Head Sub. Assembly	1	1	11 0 0 each
35008	" " Gasket	1	36	3 0 "
35449	" " Studs	4	12	1 0 "
35453	" " "	4	12	7 "
35450	" " "	2	6	9 "
35451	" " Stud Nut	10	48	10 doz.
35012	" " Cov. strap & T pce.	2	6	1 10 each
M. 1	" " Cover	1	1	1 5 6 "
	" " " Gasket	1	36	2 9 "
35054	Valve Rocker	8	12	5 0 "
35751	" " Assembly	8	8	8 2 "
35055	Eccentric Bush	8	8	3 4 "
35056	Lock Nut for ditto	8	12	3 "
35057	" Washer for ditto	8	24	9 doz.
35058	Distance Piece, valve rocker, long	2	6	3 each
35059	" " " " short	3	6	3 "
35060	" " Spring	2	6	3 "
35061	Steady Bracker	1	2	3 "
35067	Rocker Shaft, long	1	2	3 4 "
35068	" " short	1	2	3 4 "
35062	Valves	8	24	2 6 "
35063	Split Collar for ditto	(halves 16)	48	8 ea hf
35064	Valve Spring Cap	8	12	4 each
35748	" " " Cover	8	12	3 "
35064	" " Spring	8	24	6 "
35066	" " Guide	8	24	1 6 "
A. 102	Cylinder Head Cover Screw	2	6	2 0 "
35035	Camshaft	1	6	1 1 8 "
35500	" Nut	1	12	3 "
35445	Washer Camshaft Nut	1	12	6 doz.
35511	Camshaft Key	1	12	3 each
35037	" Bevel Wheel	1	2	15 4 "
35038	" " Thrust Race	2	6	7 "
35039	" " Belleville Washer	2	24	3 "
35040	" " Front Bearing	1	3	14 8 "
35042	" " Rear	1	3	11 6 "
35044	" " Driving Bevel Pinion	1	1	14 2 "
35522	Key for ditto	1	6	3 "
35089	Bevel Pinion Bearing Sleeve	1	1	9 0 "
35809	" " "	2	2	5 0 "
35090	" " Oil thrower	1	3	5 "

THE M.G. MIDGET MANUAL

Part No.	Description	Per Set	For Stock	Price £ s. d.
35807	Bevel Pinion Thrust Washer	1	3	5 each
35808	" " Washer	1	3	8 "
35091	Dynamo Coupling disc assembled	1	2	3 11 "
35092	Universal Joint fork for bevel pinion	1	1	3 4 "
35517	Nut, Dynamo coupling disc	4	12	9 doz.
35478	Lock screw, bottom bevel pinion	1	6	3 each
35801	Tab Washer front ditto	1	6	1 2 doz.
35095	Shims for Dynamo, .003"	1	3	3 each
35096	" " " .005"	1	3	3 "
35097	" " " .007"	1	3	4 "
35098	" " " .015"	1	3	5 "
35079	Dyna. Spindle & Camshaft Bevel Nut	2	6	5 "
35099	" Oil Guard w. Univ. Joint Fk.	1	1	3 11 "
35100	Lock Plate, Dynamo coupling bolt	2	6	3 "
35093	Dynamo Coupling Disc bolt	4	12	4 "
35016	Crankshaft Front Brg. Rtng. plate	1	1	10 "
35020	Lock plate for ditto	2	6	1 6 "
35017	Crankshaft rear bearing	1	3	10 6 "
35018	" " new type taper end	1	3	2 11 8 "
35463	Key for ditto, Front end	2	12	4 "
35468	" " " Rear "	1	6	3 "
20278	Crankshaft Front Bearing	1	1	18 0 "
35454	Set Screw retainer plate	4	12	3 "
35471	Crankshaft flange nut	1	3	1 10 "
35021	Lock Piece for ditto	1	6	3 "
35025	Crankshaft taper	1	3	16 10 "
35026	Shims for crankshaft bevel, .003" as reqd.		6	3 "
35027	" " " " .005" "		6	3 "
35028	" " " " .007" "		6	3 "
35030	Crankshaft Bevel Wheel with Bottom Bevel for Vertical shaft	1 pr.	1 pr.	1 11 2 pr.
35031	Shim for front cover, .003" as reqd.		6	3 each
35032	" " " " .005" "		6	3 "
35033	" " " " .007" "		6	4 "
35034	Thrust Washer, crankshaft location	1	2	1 8 "
35070	Front Bearing Housing	1	1	1 6 0 "
35029	Cover for ditto	1	1	9 6 "
35045	Con. Rod Assembly	4	12	17 4 "
35523	" " Bolt	8	24	1 1 "
35473	" " Bolt Nut	8	24	3 "
35046	Pistons (new rd. type) AX. AY. AZ.	4	4 each size	8 2 "
35048	" Rings	8	36	10 "
35050	Scraper "	4	24	11 "
35052	Gudgeon Pins	4	24	1 7 "
35512	Set Screw Small End	4	24	3 "
35053	Tab Washer for ditto	4	24	3 "
M. 6	Starting handle assembly	1	2	7 6 "
35684	" " dog	1	1	2 4 "
M. 10	" " bracket	1	2	1 3 "
*	Remetalling Con. Rod			4 3 "

SPARE PARTS

Part No.	Description	Per Set	For Stock	Price £ s. d.
LUBRICATING SYSTEM.				
CA.1225	Tap for Oil Gauge	1	3	1 6 each
35070	Sump complete	1	1	9 6 "
35406	Oil Sump Gasket	1	12	2 9 "
35078	Sump Plug	1	2	1 0 "
35079	" " Washer	1	12	$\frac{1}{2}$ "
35529	Oil Sump Set Screw	12	36	3 "
35081	" " Filler	1	1	3 2 "
35082	" " Cap	1	1	4 0 "
35405	" " Dip Stick	1	2	8 "
	Oil pump assembly	1	1	2 3 1 "
35394	Cylinder Head, Drain Pipe w. flans.	1	1	7 10 "
35398	" " Feed Pipe	1	1	8 2 "
35399	" " Drain Pipe front	1	1	7 10 "
35904	Banjo Connection Plug for ditto	1	3	7 "
35401	Relief Valve	1	3	6 "
35548	Gasket, Oil suction Pipe	2	24	8 doz.
35470	Fibre Washer, Cyl. Head Feed Pipe	1	12	4 "
35570	Gasket, Cylinder head to feed pipe	1	6	3 "
35548	" " " Oil Drain Pipe	1	12	8 "
35411	Oil Drain Housing	1	2	5 4 each
35412	Gasket for ditto	1	12	3 "
35072	Bell Housing (bushed)	1	1	2 11 8 "
CLUTCH.				
35119	Clutch Plate and centre	1	3	9 8 "
35120	" " Lever	3	12	2 0 "
35121	" " Lining	2	12	3 11 "
35122	" " Operating pin	3	12	3 "
35524	" " Adjusting screw	3	12	6 doz.
35517	Lock nut for ditto	3	12	9 "
35124	Felt for clutch lever	6	24	9 "
35125	Brass Washers for ditto	12	36	4 "
35130	Clutch Lever Spring	3	12	3 each
35129	" " Pin	3	6	3 "
35131	" " Spring	6	12	4 "
35123	" " Operating Sleeve	1	2	4 11 "
35126	" " Cover	1	1	13 4 "
35127	" " Pressure Plate	1	3	8 6 "
35514	" " Lining Rivets	12	48	3 doz.
35133	" " Thrust Bearing	1	2	12 8 each
35128	Cover for ditto	1	2	8 "
35138	Clutch pedal pull off spring	1	3	3 "
GEAR BOX.				
35102	Gear Box, studded	1	1	2 3 4 "
35078	" " Plugs	3	6	1 0 "
35079	" " " Washers	3	6	6 doz.

THE M.G. MIDGET MANUAL

Part No.	Description	Per Set	For Stock	Price £ s. d.
35376	Gear Box Top gasket	1	6	11 each
35105	1st Reverse Sliding Gear	1	1	17 8 "
35106	2nd and 3rd " "	1	1	1 0 4 "
35108	Gear Thrust Washer	4	6	9 "
35114	Main Shaft	1	1	15 6 "
35813	Layshaft	1	1	2 0 "
35363	Change Speed Lever	1	2	5 0 "
35394	" " " knob	1	12	1 1 "
FRONT AXLE.				
35140	Axle Beam	1	2	2 0 4 "
35141	Bush, Steering knuckle bottom	2	12	1 8 "
35852	" " " Top	2	12	1 10 "
35143	Bolt " "	2	12	4 8 "
35144	Thrust Washer for bolt	2	12	10 "
35145	Front Hub	2	2	9 8 "
35146	Distance piece	2	2	8 "
35148	Steering Knuckle O/S	1	1	18 10 "
35149	" " N/S	1	1	18 10 "
35150	" Arm	1	2	4 6 "
35152	Front Hub Inner Bearing	2	6	9 6 "
JA 5192	" " Outer "	2	6	9 9 "
35154	Felt Washer	2	12	3 "
1706	Nut, Steering knuckle bolt	2	12	3 "
5482	Cotter Steering knuckle bolt	2	12	4 "
5517	Nut for ditto ditto	2	12	9 doz.
	Track Rod Assembly	1	1	15 0 each
STEERING.				
	Steering Assembly	1	1	5 12 6 "
	" Wheel	1	1	2 2 0 "
35761	" " Set Screw	1	3	11 "
35309	" Column Ball Race, Upper	1	3	6 10 "
35310	" " " " Lower	1	3	2 10 "
35503	Lock Nut for ball race	1	6	10 "
35320	" Box Nut	1	2	1 8 "
35321	Locking Washer	1	12	5 doz.
3450	Steering Column Clamp	1	2	3 0 each
35322	" Thrust Screw	1	6	6 "
35502	Lock Nut for ditto	1	6	3 "
M. 702	Steering Column outer tube N.P.	1	1	13 6 "
35324	Lower Ball Race Housing	1	3	1 5 "
35315	Steering Gear Box bush, long	1	3	2 6 "
35316	" " " " short	1	3	1 8 "
35317	" Worm	1	2	10 0 "
35327	" " Wheel	1	2	14 4 "
35326	" Box studded	1	2	13 0 "
35314	" " cover	1	2	3 4 "

SPARE PARTS

Part No.	Description	Per Set	For Stock	Price £ s. d.
35500	Studs for Box	4	12	3 each
35558	Key for Steering	1	12	3 "
35559	Bolt for Steering Box	1	6	10 "
35329	Felt Washer	1	6	3 "
35498	Castle Nut for Steering Box	1	6	3 "
35184	Steering ball	5	5	1 4 "
35179	Drop Arm	1	3	4 10 "
35180	" " stop	2	6	7 "
3505	Castle Nut for ball end	4	6	3 "
35498	" " steering ball	5	8	3 "
35182	Draglink	1	2	3 8 "
35183	Ball Joint body R.H.T.	1	2	3 11 "
35186	" " L.H.T.	1	2	3 11 "
35185	" " Plug	2	6	10 "
35497	Lock Nut	1	6	3 "
35499	" "	1	6	3 "
CONTROLS.				
	Mixture control rod complete	1	2	
	Yoke end for ditto	1	3	6 "
	Pin for ditto	1	6	2 "
3803	Accelerator Springs	1	6	4 "
3645	" Lever	1	2	1 4 "
3740	" Pedal Lever	1	2	2 5 "
REAR AXLE.				
35333	Rear Axle housing assembly	1	1	3 0 8 "
35334	" " banjo	1	1	2 5 10 "
35335	" " cover	1	1	5 8 "
35174	" Hub Nut O/S	1	3	1 3 "
35175	" " N/S	1	3	1 3 "
35178	" " Drain Plug	1	3	3 "
35344	" " Shaft	2	4	16 0 "
35346	Rear Hub Lock Washer	2	6	3 "
JA.5716	" " Bearing	2	2	14 5 "
35347	" " Felt	2	6	9 "
35177	Inspect. Plug & Breather (Front cov.)	1	2	8 "
35542	Washer for ditto	1	6	5 doz.
35828	Banjo Oil retng. sleeve & leath. wash.	2	2	2 4 each
35343	Rear Hubs	2	2	13 2 "
35469	Rear Axle Set Screw	8	8	3 "
35173	" " Dowel	8	8	3 "
35156	" " Front Cover	1	1	1 10 8 "
35157	Diff. Bearing Cap	2	2	4 4 "
35829	Bevel Pinion Housing	1	1	13 0 "
35159	Cap, bevel pinion housing	1	1	5 8 "
35161	Bevel pinion washer	1	6	4 "
35162	Distance piece for pinion bearing	1	2	8 "

THE M.G. MIDGET MANUAL

Part No.	Description	Per Set	For Stock	Price	
				£	s. d.
35163	Universal joint spider	1	3	4	6 each
35164	Drive gear and pinion	1	1	2	9 2 "
35165	Diff. Case N/S	1	1	16	10 "
35166	" " O/S	1	1	14	10 "
35167	" Bearing nut	2	4	1	2 "
35168	" Wheel	2	2	10	6 "
35169	" Pinion	2	2	5	4 "
35170	Pin for Diff. pinion	1	6		8 "
35171	Pinion dowel	1	6		6 doz.
35562	Stud for Diff. bearing cap	4	12		3 each
35563	Diff. case bolt	6	12		7 "
35777	Castle nut for ditto	6	12		3 "
35340	Bevel Pinion bearing, fin. at No. 350	2	2	12	0 "
35340	" " " com. at No. 351	1	1	12	0 "
35832	" " Roller Bear. begin at "	1	1	16	8 "
35341	Diff. Bearing	2	2	12	10 "
35342	Lock Washer for ditto	2	4		3 "
35349	Prop. Shaft with spider	1	1	1	0 4 "
3411	Fabric Disc	2	2	7	10 "
35556	Rear Axle Spider slotted nut	1	2		3 "
35337	Bevel Pinion Shims .003"	as reqd.	6		3 "
35338	" " " .005"	"	6		3 "
35339	" " " .007"	"	6		3 "
CA.1215	Oil Filler Plug (Rear Axle)	1	6		9 "
35509	Washer for ditto	1	6		8 doz.
3389	Bolt for Fabric Disc	12	12		3 each
35526	Stud for front cover	8	12		10 doz.
35351	Rear Hub Bearing housing gasket	2	12		3 each
35352	Rear and Front cover gasket	2	12		3 "
3764	Universal Joint cover	1	1	3	11 "

SPRINGS.

3623	Front Spring with top clamp plate and bottom snubber bracket O/S	1	1	19	0 "
35816	Ditto ditto ditto N/S	1	1	19	0 "
35666	Front top rebound leaf and clips	2	2	3	11 "
35667	" 2nd " " " "	2	2	4	6 "
3407	" Spring Packing	2	2		7 "
3624	Rear Spring assem. with top clamp plate and bottom snubber O/S	1	1	1	2 4 "
35655	Ditto ditto ditto N/S	1	1	1	2 4 "
35672	Rear Spring top rebound leaf & clip	2	2	4	2 "
35673	" " 2nd " " " "	2	2	4	10 "
3495	" " Clips	4	4		6 "
3328	" " Shackle	4	4		9 "
3347	" " " Pin	10-8	12		1 8 "
3501	" Shackle Pins (front dumb iron)	2	4		1 10 "
3593	Spring Pin (Rear Spring Front End)	2	4	2	6 "
3454	" " Nut	10	10		3 "

SPARE PARTS

Part No.	Description	Per Set	For Stock	Price £ s. d.
BRAKE GEAR.				
M. 801/2	Brake Shaft Bracket and Cap	2	2	11 3 pair
M. 808	„ Rod Steady Bracket	2	2	1 0 each
	„ Cables	4	6	11 3 „
M. 809	„ „ Brackets	4	2	9 „
M. 807	„ Rod Steady	4	2	6 „
M. 818	Cable Bracket Rear	2	2	2 0 „
A. 100	Brake Cross Shaft Assembly	1	1	1 15 0 „
M. 810	„ Adjuster	4	4	8 „
M. 814	Clevis Pin for Brake gear	6	12	3 „
M. 811	Brake Rods Front	2	4	5 3 „
	Main Brake Adjuster (assembled)	1	1	10 6 „
M. 815	Brake Adjuster Rod R.H.	1	2	4 6 „
M. 816	„ „ „ L.H.	1	2	4 6 „
M. 817	Brake Adjuster	1	2	1 4 „
M. 812	Rear Brake Rods	2	4	5 3 „
M. 824	Bell Crank Lever	1	3	2 6 „
M. 823	„ „ Bracket	1	3	2 3 „
M. 825	Studs for ditto	1	6	4 „
M. 1005	Brake Pedal Brackets assembled	1	1	11 0 „
35277	„ Drums with Steel Bands	4	2	15 0 „
35228	„ Brackets, Front	2	2	3 11 „
35679	„ „ Rear	2	2	3 11 „
35489	Front Brake Bracket Bolt, Short	4	12	6 „
35490	„ „ „ „ Long	4	12	7 „
35508	Bolt, Rear Brake Bracket	8	12	4 „
35229	Brake Cam Bush	8	8	1 7 „
35230	Brake Cam	4	6	6 3 „
35231	„ „ Washer, Inner	4	12	6 doz.
35232	„ „ „ Outer	4	12	6 „
35233	„ Fulcrum Pin	4	4	1 8 each
35234	„ Cam Lever	4	4	3 0 „
35235	„ Shoe Bare	4	4	5 6 „
35653	„ „ Assembly	4	4	8 6 „
35239	„ „ Lining Halo	8	12	2 1 „
35774	Rivet for Lining	64	72	4 doz.
35511	Brake Cam Key	4	12	3 each
35240	Brake Shoe Spring	8	16	3 „
35554	Bolt for Cam Lever	4	12	3 „
35517	Nut for ditto	4	12	9 doz.
35487	Countersunk Screw for Brake Drum	12	24	3 each
FRAME.				
3367	Main Cross Member—Front	1	1	7 0 „
3498	Rear Dumb Iron	2	2	3 6 „
3608	Main Cross Member Bracket	1	1	1 4 „
3629	Rear Spring Bracket (Front) O/S	1	1	11 0 „
3628	„ „ „ „ N/S	1	1	11 0 „
3349	Main Cross Member—Front	2	2	2 4 „
3355	Front Spring Bracket—Rear	2	2	4 3 „

3/31/11

Spare Parts. Page Seven

THE M.G. MIDGET MANUAL

Part No.	Description	Per Set	For Stock	Price	
				£	s. d.
3835	Steering Gear Box Support	1	2	6	6 each
3734	Engine Support Bracket O/S	1	2	8	"
3735	" " " " N/S	1	2	8	"
3584	Snubber Bracket—Rear Top O/S	1	2	10	"
3585	" " " " N/S	1	2	10	"
3603	Battery Carrier Support	1	1	1	8 "
	Chassis Frame Complete	1	1	6	0 0 "
EXHAUST SYSTEM.					
	Exhaust Manifold	1	2	2	2 6 "
	" Chamber	1	1	1	0 0 "
	Front Exhaust Pipe	1	1	7	6 "
	Tail Pipe	1	1	7	6 "
	Exhaust Flange Gasket	1	12	10	" "
	" Manifold Gasket, Centre	1	12	7	" "
	" " " Front	1	12	6	" "
	" " " Rear	1	12	6	" "
RADIATOR.					
3421	Water Hose Top	1	6	2	11 "
3420	" " Bottom	1	6	1	9 "
2611	" " Clip, 1½	1	6	11	" "
3565	" " " 1½	1	6	10	" "
35685	" Outlet Pipe	1	2	6	3 "
35687	" " " Gasket	1	6	7	" "
35073	" " " Set Screw	2	6	3	" "
BONNET.					
	Bonnet unpainted	1	1	1	15 0 "
	" painted	1	1	2	15 0 "
	" Fasteners	2	6	4	6 "
FAIRINGS.					
	Front Apron, unpainted	1	1	7	6 "
	" " painted	1	1	15	0 "
	" " Rear support, unptd.	1	1	1	6 "
	" " " painted	1	1	3	0 "
	" Wing, unpainted O/S	1	1	1	5 0 "
	" " painted O/S	1	1	1	17 0 "
	" " unpainted N/S	1	1	1	5 0 "
	" " painted N/S	1	1	1	17 0 "
	Rear " unpainted O/S	1	1	1	5 0 "
	" " painted O/S	1	1	1	17 0 "
	" " unpainted N/S	1	1	1	5 0 "
	" " painted N/S	1	1	1	17 0 "
	Side Valances, unpainted O/S	1	1	10	6 "
	" " " N/S	1	1	10	6 "
	" " painted	1	1	15	6 "
	Rear Dumb Iron Vals., unptd. O/S	1	1	7	6 "
	" " " painted O/S	1	1	15	0 "
	" " " unptd. N/S	1	1	7	6 "
	" " " painted N/S	1	1	15	0 "

Standardised Repair Charges for the 8/33 M.G. Midget Sports :

	£	s.	d.
Decarbonise, grind in valves, reassemble, adjust tappets, tune-up generally and test car on road	2	0	0
Examine and adjust tappets	3	0	0
Clean and adjust sparking plugs, per set	2	0	0
Remove exhaust manifold, clean out, and refit with new gaskets	5	0	0
Remove front and exhaust pipe from manifold, fit new washer and refit	3	0	0
Remove carburetter, dismantle, clean, adjust, reassemble, refit and test	7	6	0
Adjust carburetter and test	3	6	0
Remove sump, clean, replace, and refill	7	6	0
Adjust distributor points	1	0	0
 CLUTCH :			
Remove from engine, dismantle, examine and clean all parts, fit any new material, reassemble completely, adjust clutch control, readjust brake gear	2	5	0
Adjust and test	5	0	0
 GEARBOX :			
Remove from chassis, dismantle, examine, clean, fit all new material necessary, reassemble completely, re-erect and adjust. Re-adjust brake gear	2	0	0
 CARDAN SHAFT :			
Universal joint : Dismantle universal joint, fit necessary new parts, adjust and reassemble	12	6	0
 REAR AXLE :			
Remove rear axle diff. cover, clean inside of housing and replace	4	0	0
Remove pinion sleeve locking plate, and oil thrust bearings ...	1	6	0
Remove rear axle from chassis, take apart and thoroughly clean, examine and test, fit any new parts necessary, adjust and reassemble, and refit to chassis complete. Re-adjust rear brake gear	3	0	0
Remove brake drum and withdraw half axle shaft, fit new shaft, refit drum, etc., each	5	0	0

THE M.G. MIDGET MANUAL

	£ s. d.
FRONT AXLE :	
Remove front axle, take apart stub axles, fit all new parts necessary, reassemble and refit. This includes wheel hubs and front wheel brake gear	2 15 0
Front hub, dismantle, clean and reassemble	6 0
Stub axle, dismantle and fit new pin and bushes, each	18 0
Fit new stub axle, each	12 6
STEERING :	
Remove steering column and gearbox from chassis. Take apart, clean and adjust, fit necessary new parts, reassemble complete with all controls	1 5 0
Steering lever, fit new ball	5 0
Steering arms, fit new ball	6 0
Track rod, dismantle, clean balls and cups, refit and re-track	5 6
Draglink, dismantle, clean balls and cups, and refit	7 6
Steering arm, fit new ball and ball seats, each	4 0
Ditto, both arms	6 0
Steering arm, remove and fit new, each, off-side	3 0
Ditto, each, near-side	3 0
Lining up track of front wheels	3 6
BRAKES :	
Remove rear brake drum, dismantle brake mechanism, clean drum and mechanism, reassemble and adjust ... each	7 6
Re-line foot brakes—dismantle all foot-brake parts, re-line shoes, fit necessary new parts, reassemble, ease and adjust all foot brake control gear. Test on road	2 5 0
Re-line hand brake as above	7 6
Adjust and equalise foot and hand brakes, and ease all control gear	7 6
Machine brake drums, each	5 0
SPRINGS :	
Dismantle rear springs, clean, fit new parts where necessary, grease and reassemble	1 5 0
Dismantle front springs, clean, fit new parts where necessary, grease and reassemble	1 0 0
Fit new shackle bolts to front spring, per spring	3 6
Fit new shackle bolts to rear spring, per spring	6 6
Fit new spring clips, per spring	2 6
Spring shackles, take up side play	5 6
Fit new speedo. cable complete	3 6
Petrol tank, remove and refit	1 10 0
Lubricate all nipples and wheel hubs	3 6
Adjust shock absorbers and test on road	5 0

Oiling Chart for the 8/33 M.G. Midget Sports Two-seater.

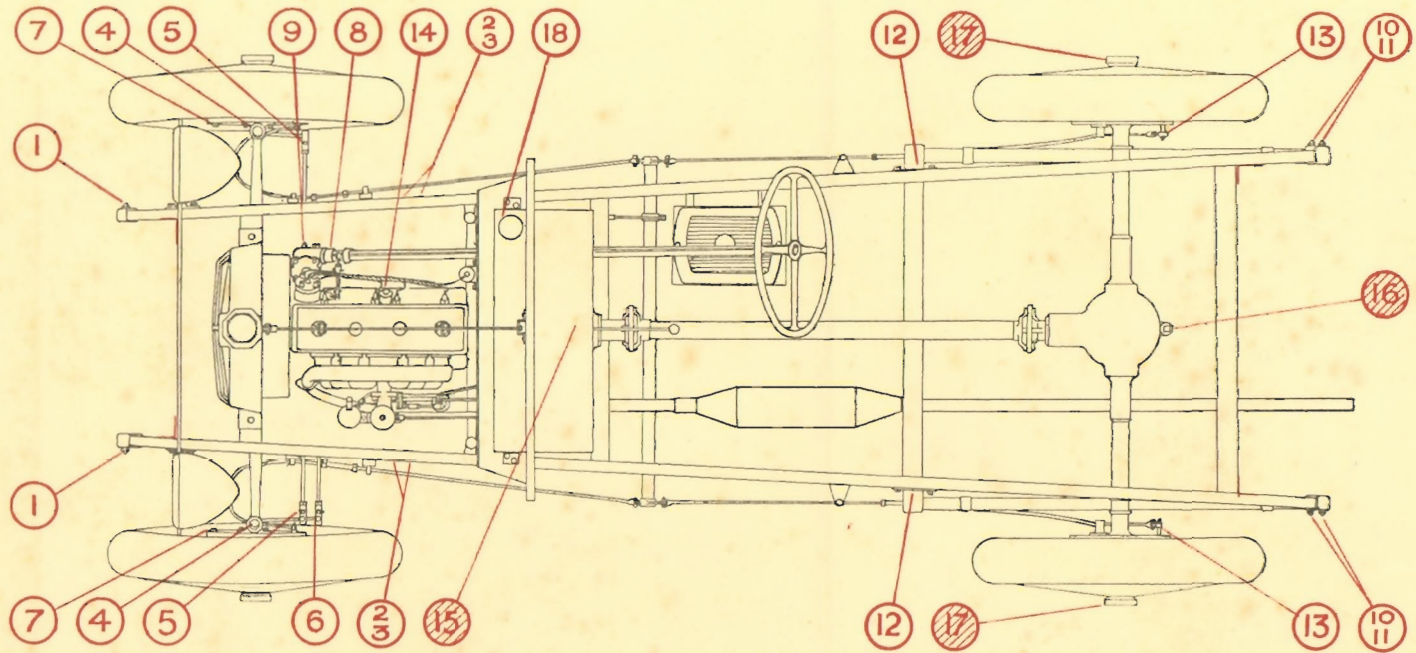

Every 250 miles.



Every 2000 miles.

E—Engine Oil.

G—Gear Oil.

1	Front spring front shackle	2 points.	G
2 & 3	rear "	4 points.	G G
4	King pins	4 points.	G G
5	Track Rod	2 points.	G G
6	Drag Link	2 points.	G G
7	Camshafts brake front	2 points.	G G
8	Steering box thrust	1 point.	G G
9	Steering box	1 point.	G G
10 & 11	Rear spring rear end shackles	4 points.	G G
12	" front end shackle	2 points.	G G
13	Brake camshaft, rear	2 points.	G G
14	Sump		E
15	Gear Box		G G
16	Rear Axle		G G
17	Rear wheel hub	2 points.	G G
18	Brake pedal	1 point.	G